

TTC-IIS Series Miniature Diaphragm Pumps (air/gas)

Up to 11 LPM Free Flow



Typical Applications

- Gas Analysis
- Anesthesia Monitors
- CO₂ Monitors
- Patient Monitoring
- Wound Therapy
- Urinalysis
- Trace Detection
- Medical/Training Mannequins
- Degassing

TTC-IIS Miniature Diaphragm Pumps are a series of brush and brushless DC motor driven pumps, which are tailored to meet the specific application performance requirements. An innovative compact design incorporates leading edge technologies that allow them to operate more efficiently than existing pump designs. TTC-IIS pumps offer multiple component configurations allowing them to be used for either vacuum, pressure, or alternating vacuum and pressure operations. The TTC-IIS Series is best for compact and low pressure applications that require high efficiency.

Features:

- TTC-IIS Series' innovative and efficient design pushes the performance envelope in a lightweight, compact size which allows it to operate at the highest performance/size ratio.
- Highest efficiency in class. The TTC-IIS supports low power for portable and battery powered instruments.
- Using our proprietary advanced diaphragm elastomer and superior brushless motor design sets the highest benchmark for service-free operation that exceeds 10,000 hours.
- Incorporating the lightweight EZ Mount accessory facilitates simple system assembly while dampening vibration and reducing noise levels.
- RoHS compliant. 

Product Specifications*

Physical Properties

Operating Environment¹:	41 to 122°F (5 to 50°C)
Storage Environment:	-4 to 212°F (-20 to 100°C)
Media:	Air, Argon, Helium, Nitrogen, Oxygen, and other non-reacting gases
Humidity:	0 – 80% Relative Humidity
Noise Level²:	As low as 45dB @ 12 in (30 cm) <i>Muffler recommended for additional noise reduction (see accessories)</i>
Pump Assembly Rated Life³:	PMDC Iron Core Brush - 3,000 hrs Brushless Slotted - 10,000 hrs Brushless Slotless - 10,000 hrs
Weight:	8.6 oz. (244 g) PMDC Iron Core Brush 6.2 oz. (176 g) Brushless Slotted 9.0 oz. (255 g) Brushless Slotless

Electrical

Motor Type (DC):	PMDC Iron Core Brush, Brushless Slotted, Brushless Slotless
Nominal Motor Voltages⁴:	6, 12 or 24 VDC <i>Other voltages available upon request</i>
Electrical Termination:	PMDC Iron Core Brush: 22 AWG Wire Leads, Length 10" (254 mm) Brushless Slotted Motor: 22 AWG Wire Leads, Length 20" (508 mm) Brushless Slotless: 22 AWG Wire Leads, Length 20" (508 mm)
Current Range⁵:	240 - 880 mA

Wetted Materials

Diaphragm:	EPDM, AEPDM, FKM
Valves & Gaskets:	EPDM, FKM
Pump Head:	Vectra (Liquid Crystal Polymer)
Valve Cover:	303 Stainless Steel

Pneumatic

Head Configuration:	Dual
Maximum Unrestricted Flow:	6 LPM (Per head), 11 LPM (Parallel)
Pressure Range:	0 - 12 psig (0 - 0.8 bar) Parallel
Vacuum Range:	0 - 16 in Hg (0 - 406 mm Hg)
Filtration	40 microns - recommended
Efficiency at Free Flow⁶	PMDC Iron Core Brush: 1.2 LPM/Watt (PN: TD001-13) Brushless Slotted: 1.6 LPM/Watt (PN: TD003-11) Brushless Slotless: 1.5 LPM/Watt (PN: TD005-12)

* See Appendix A for details.

Performance Specifications

TTC-IIS - Brushless Slotted Motor

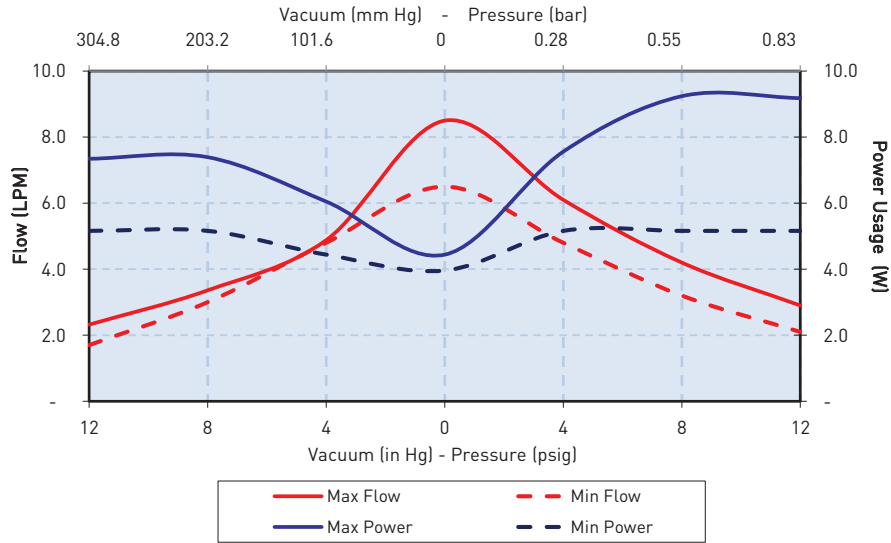

TTC-IIS - Brushless Slotless Motor

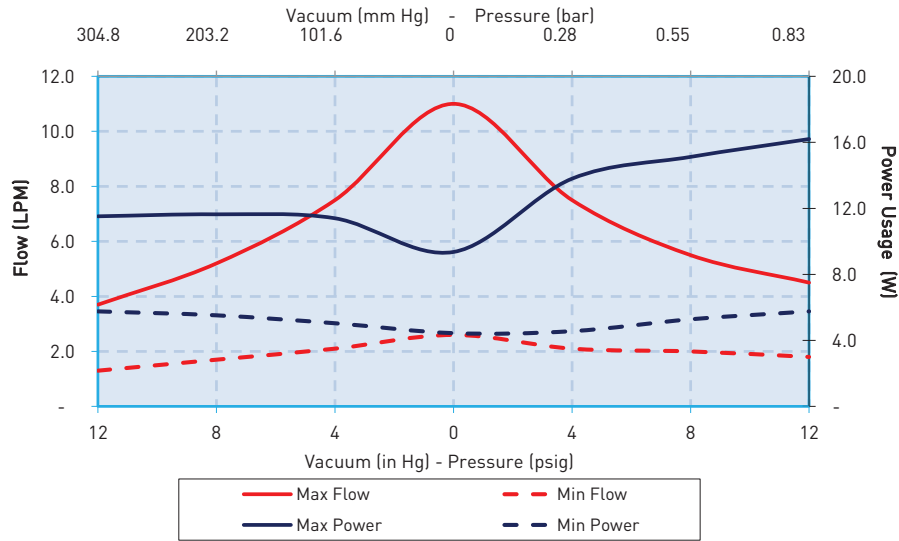

The above graph represents an example of performance for the pumps series handling air at 800 feet (244m) above sea level at 75°F (24°C). Performance will vary depending on barometric pressure and media temperature. Curves are representative of standard pump configurations. Pump configurations could be customized for higher or lower flows, depending on specific customer requirements.

Please contact Parker Precision Fluidics Applications Engineering for other considerations.



TTC-IIS Series

Miniature Diaphragm Pumps (air/gas)

Sizing and Selection

TTC-IIS Series

PMDC
Iron Core Brush

Brushless
Slotted Motor

Brushless
Slotless Motor

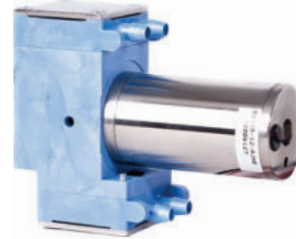

	PMDC Iron Core Brush	Brushless Slotted Motor	Brushless Slotless Motor
Efficiency¹	Good	Better - Up to 60% motor efficiency at low loads	Best - Up to 75% motor efficiency at high power levels
Life²	Good - 3,000 hrs	Best - 10,000 hrs	Best - 10,000 hrs
Cost	Best	Better	Premium
Noise	Good	Better	Best

Mounting Guidelines:

- Bracket options available for mounting consideration (See *EZ Mount catalog pages*).
- Hole in the center of the bottom of housing is for manufacturing only—not to be used for mounting.
- Mounting holes are drilled for #6-20 self-tapping screws with 1/4" (6 mm) thread engagement 4 in-lbs. (0.45 N-m).

Port Connections:

- Barbs are sized for 1/8" (3 mm) ID tubing, 70-80 durometer recommended.
- Flow direction is marked on the pump head with arrows.

Mechanical Integration

Dimensions

PMDC Iron Core Brush

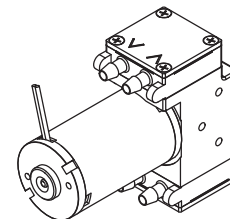
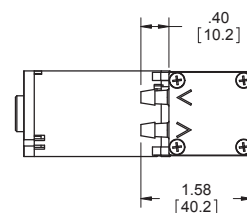
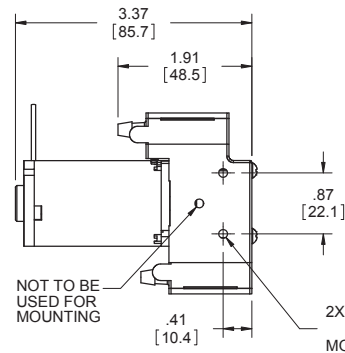
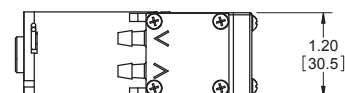
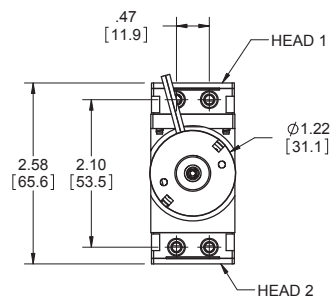

UNITS
IN. [mm]



Mechanical Integration

Brushless Slotted Motor

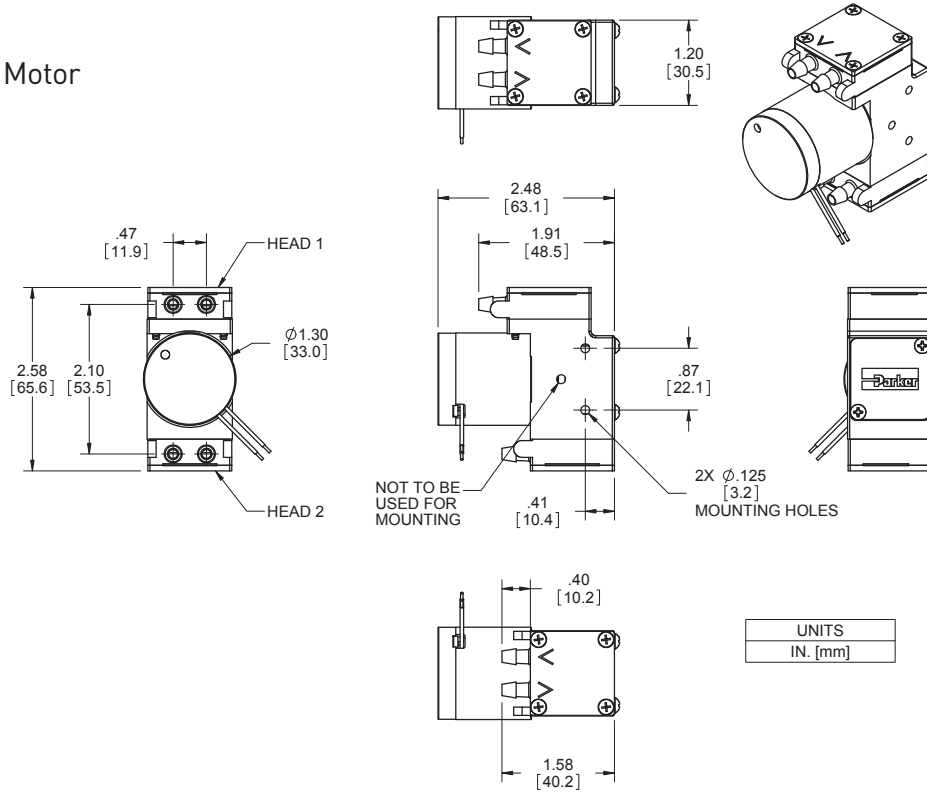

Brushless Slotless Motor

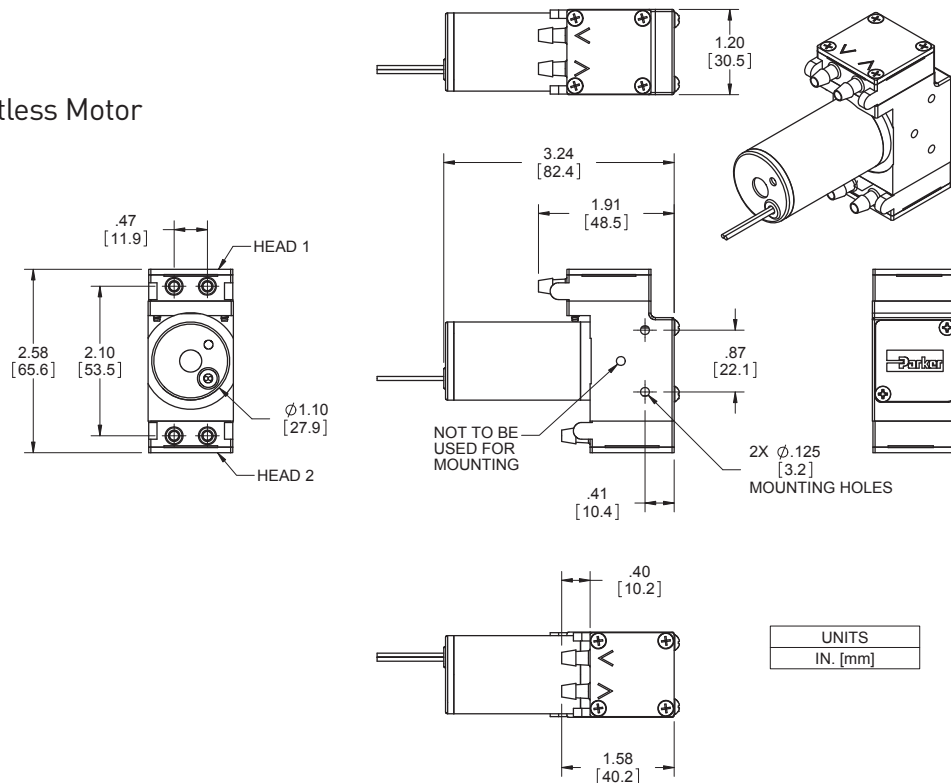

TTC-IIS Series

Miniature Diaphragm Pumps (air/gas)

Electrical Integration and Motor Control

PMDC Iron Core Brush Motor

2 Wire	Red (+), Black (-)
Wire specification	22AWG, Insulation OD 0.051 in (1.30 mm), 10" (254 mm) Wire Leads

Brushless Motor Control Options

2 Wire	Red (+), Black (-)
3 Wire (Speed Control)	Red (+), Black (-), White (PWM) or Yellow (Analog)
4 Wire (Speed Control & Feedback)	Red(+), Black (-), White (PWM) or Yellow (Analog), Blue (Tachometer)
Wire specification	22AWG, Insulation OD 0.051 in (1.30 mm), 20" (508 mm) Wire Leads

Other Motor Control Considerations

The drive electronics for the BLDC motors are integrated into the motor itself, all that is needed is a power supply with the sufficient voltage and current.

Key Things to Remember

The pump is not a pressure holding device. An external check valve is recommended, if there is a pressure holding requirement.

Pump orientation does not affect performance or life.

Pulse Width Modulation (PWM)

Pulse-width modulation is a commonly used technique for controlling DC motors.

The average value of the voltage fed to the motor is controlled by turning a switch between the voltage supply and the motor on-and-off at a fast pace. The longer the switch is on compared to the off time, the higher the power supplied to the motor.

The PWM switching frequency varies for different types of devices, and is selected based on how it affects the device. For example, some applications require a faster switching frequency to prevent audible noise or electrical noise.

The term duty cycle describes the ratio of on-time to the period (one complete on-and-off cycle). Duty cycle is normally expressed as a percentage of on-time, 100% being full-power and 50% being half-power.

The advantage of PWM is the reduction of power-loss due to switching versus other control methods. Parker Hannifin recommends controlling the pump using 15kHz - 20 kHz frequency range.

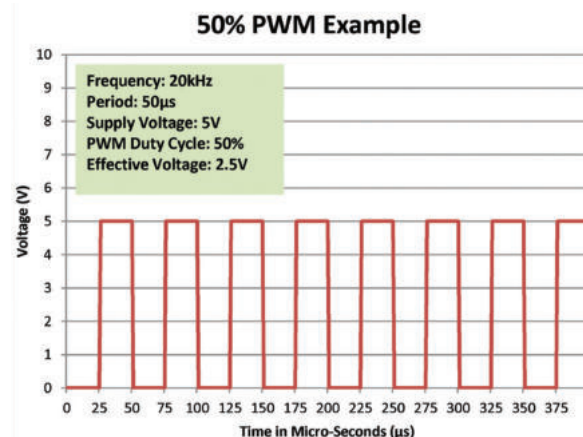
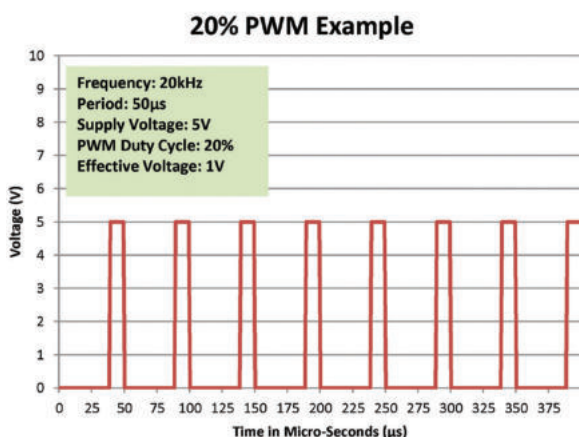

Typical Flow Diagram

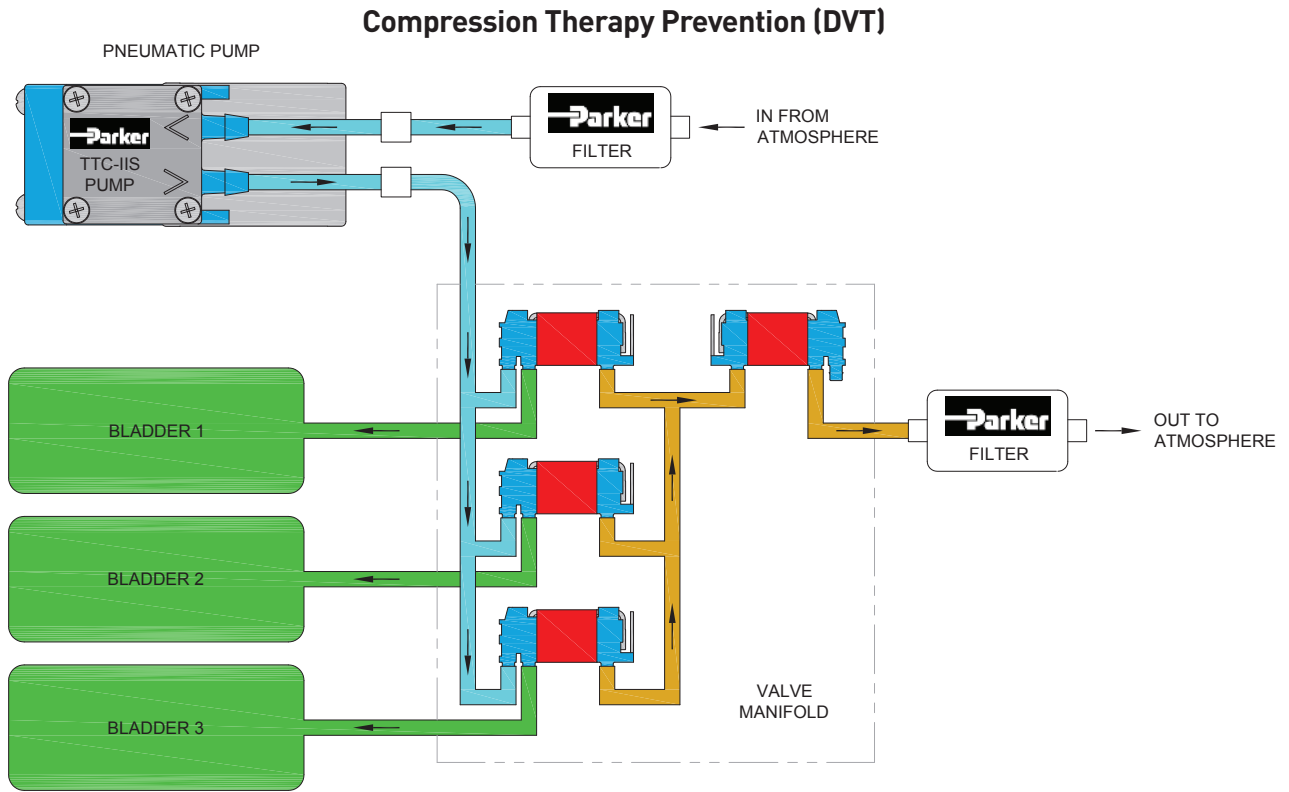

Accessory Information

Filter-Mufflers also available to assist with filtration and optimize noise reduction.

Part Number: 00492-15
(Filters to 10 microns)

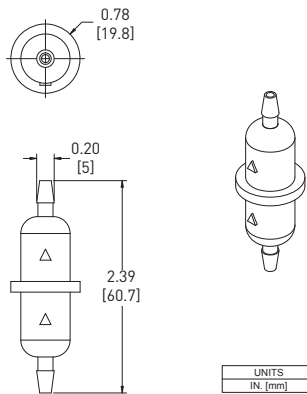

TTC-IIS Series

Miniature Diaphragm Pumps (air/gas)

Accessory Information

EZ Mount available

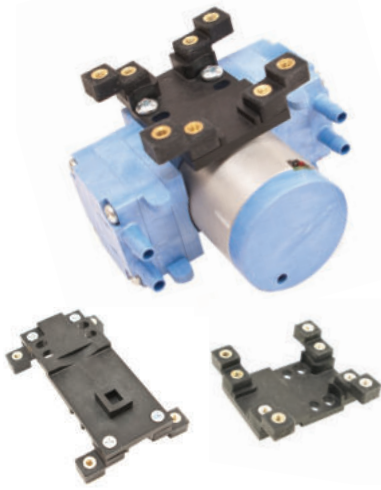

EZ Mount provides ease of installation and effective control of vibration transfer. EZ Mount was designed to mount easily to the Precision Fluidic TTC-IIS Family of diaphragm pumps.

Features

- Isolation feet on the EZ mount can be rotated in any one of three ninety-degree planes and is designed for top-down or bottom-up mounting providing simple installation.
- EZ Mount was designed to minimize weight added to the pump assembly. Approximate weights are: Style A - 0.63 oz (18 g), Style B - 0.71 oz (20 g).
- Effectively absorbs vibration to minimize most vibration-induced noise and vibration transfer into an instrument.
- Designed to keep height and size to a minimum.
- Engineered for Parker TTC-IIS pumps to ease integration into your system.

Physical Properties

Operating Environment:

41 - 158°F (5 - 70°C)

Humidity:

0 - 95% Relative Humidity

Base Plate:

Noryl GTX830

Feet:

Silicone

Feet Insert:

Brass

Hardware:

Zinc-Plated Steel

EZ Mount kits include all necessary hardware and detailed instructions.

Isolation Feet are available in either threaded or thru-hole clearance for standard #4-40 (M3.5 for clearance hole only) or #6-32 hardware and can be mounted in any of three ninety-degree planes.

Dimensions

Style A

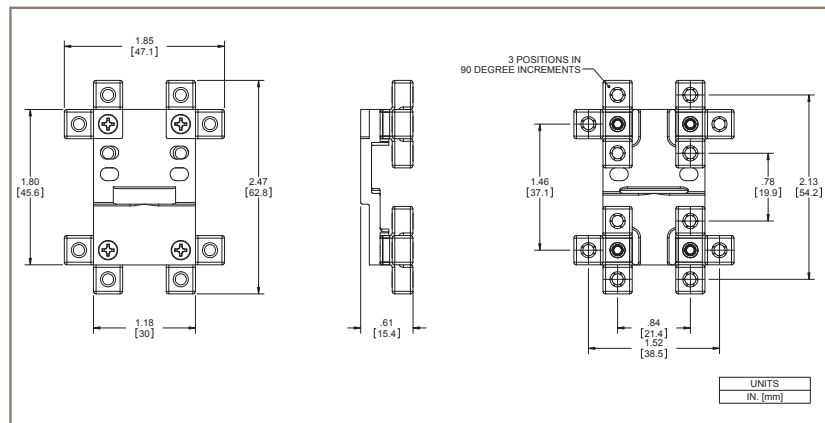

Style B

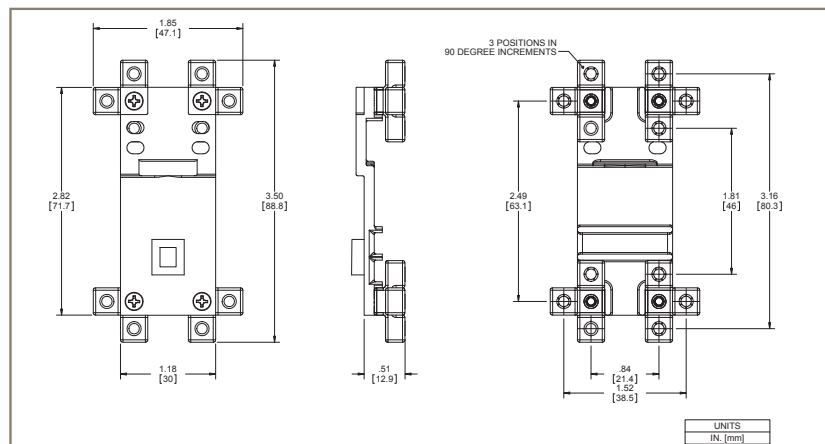

Miniature Diaphragm Pumps (air/gas)

TTC-IIS Series

Ordering Information

TTC-IIS Dual Head Pumps - General Purpose

Part No.	Vacuum: LPM @ Load				Free Flow	Pressure: LPM @ Load				Max			PCD*	Wetted Materials
	16 in Hg 406 mm Hg	12 in Hg 305 mm Hg	8 in Hg 203 mm Hg	4 in Hg 102 mm Hg		4 psig 276 mbar	8 psig 55 mbar	12 psig 827 mbar	16 psig 1103 mbar	Vac in Hg	Press psig	Motor Type		
TD003-11	1.7	3.0	4.8	6.5	4.8	3.2	2.1		12.0	16.0	Brushless Slotted	12	570	AEPDM, EPDM, EPDM

* PCD: Peak Current Draw

TTC-IIS Dual Head Pumps - High Flow

Part No.	Vacuum: LPM @ Load				Free Flow	Pressure: LPM @ Load				Max			PCD*	Wetted Materials	
	16 in Hg 406 mm Hg	12 in Hg 305 mm Hg	8 in Hg 203 mm Hg	4 in Hg 102 mm Hg		4 psig 276 mbar	8 psig 55 mbar	12 psig 827 mbar	16 psig 1103 mbar	Vac in Hg	Press psig	Motor Type			
TD001-13					6.8	4.9	3.4	2.4	1.5		16.0	PMDC Brush	12	630	EPDM
TD004-13					8.5	6.1	4.2	2.9			16.0	Brushless Slotted	12	880	EPDM
TD005-12					8.8	7.4	5.5	3.8			16.0	Brushless Slotless	12	630	EPDM
TD002-13					8.5	6.1	4.2	2.9			16.0	Brushless Slotted	12	770	EPDM

* PCD: Peak Current Draw

Note: The Ordering Information Section includes a few selected part numbers for the product line. Other performances and configurations are available. Please contact your Sales Representative or an Application Engineer to discuss your application needs.

Accessory Information

Part No.	Filtering Level (Micron)	Filter Area	Internal Volume	Operating Limitations:			Wetted Materials
				Max Temperature 80°C	Min Temperature 32°C	Max Pressure 65 PSI (4.48 bar)	
00492-15	10	1.71 in ² (11 cm ²)	0.24 in ³ (3.9 cm ³)				Polypropylene
Filter-Mufflers: To assist with filtration and optimize noise reduction. Tubing: Recommendation 1/8" (3mm) ID.							

EZ Mount for TTC-IIS Dual Head Pump with
PMDC Iron Core Brush Motor

Part Number	Style	Description
00332-10-A45S	B	#4-40 Threaded
00332-10-B45S	B	#4 / M3.5 Clearance
00332-10-D45S	B	#6-32 Threaded
00332-10-C45S	B	#6-32 Clearance

EZ Mount for TTC-IIS Dual Head Pump with
Brushless Slotted Motor

Part Number	Style	Description
00328-10-A45S	A	#4-40 Threaded
00328-10-B45S	A	#4 / M3.5 Clearance
00328-10-D45S	A	#6-32 Threaded
00328-10-C45S	A	#6-32 Clearance

EZ Mount for TTC-IIS Dual Head Pump with
Brushless Slotless Motor

Part Number	Style	Description
01074-10-A45S	B	#4-40 Threaded
01074-10-B45S	B	#4 / M3.5 Clearance
01074-10-D45S	B	#6-32 Threaded
01074-10-C45S	B	#6-32 Clearance

TTC-IIS Series

Miniature Diaphragm Pumps (air/gas)

Ordering Information

Please click on the Order On-line button below (or go to www.parker.com/precisionfluidics/ttciis) to configure the TTC-IIS Miniature Diaphragm Pump for your application.

Serviceable – PPF products are designed for use through the rated life and Parker does not sell replacement parts, nor is it recommended to service these in the field

Note: In addition to Parker's innovative and flexible pump designs, we offer applications engineering expertise to our customers in order to configure and recommend the optimal pump for the application. Contact Parker Applications Engineering to discuss and configure alternate pump configurations to meet your specific application requirements. Providing information on the following requirements will assist us in developing an optimal solution for your application:

- Noise
- Operating Pressure / Vacuum
- Power Consumption
- Life Requirement
- Description of pump function in the application
- Size
- Motor Control
- Media
- Voltage



Appendix A

All performance data is typical based on standard conditions: 70°F and 14.7 psia (21°C and 1 bar).

1. Duty Dependent. For operation above 122°F (50°C) consult factory
2. Noise is dependent on the configuration and operation of the pump in the application. Parker has the ability to tailor the pump configuration when noise is a critical criterion in the effort to meet the performance requirements of the application. Noise level is tested to Parker protocol P-105.
3. Life rating can vary depending on application and operating conditions.
4. Custom motor options available. Custom motors may require a significant application potential. The standard motors can be configured with a special winding to meet a particular operation point at a specified voltage
5. Current range is dependent on motor type, voltage, pressure/vacuum and flow requirement. Lower levels possible depending on application.
6. Pump efficiency is a measure of the flow rate generated per unit of power consumed. Efficiency may change dependent on application and operating condition at free flow.



