

Characteristics / Ordering Code

Parker electronic modules PWD00A-400 for rail mounting are compact, easy to install and provide time-saving wiring by disconnectable terminals. The digital design of the circuit results in good accuracy and optimal adaption for proportional directional control valves by a comfortable interface program.

Features

The described electronic unit combines all necessary functions for the optimal operation of proportional directional control valves without position sensor (series D*FB, D*1FB). The most important features are:

- Digital circuit design
- Four parameterizable command channels
- Constant current control
- Differential input stage
- Status output
- Four-quadrant ramp function
- Enable input for solenoid driver
- Status indicator
- Parametering by serial interface RS232C
- Connection by disconnectable terminals
- Compatible to the relevant European EMC standards
- Comfortable PC user software, free of charge:
www.parker.com/euro_hcd - see "Support", or directly at www.parker.com/propxd.

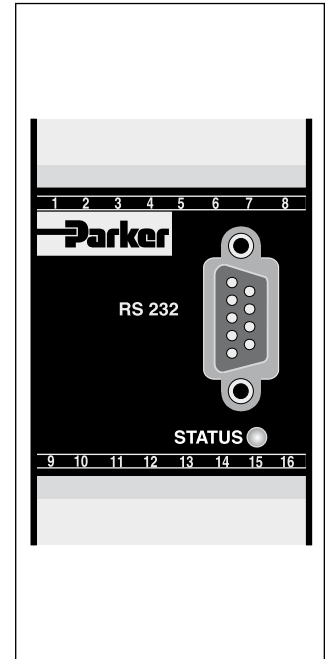
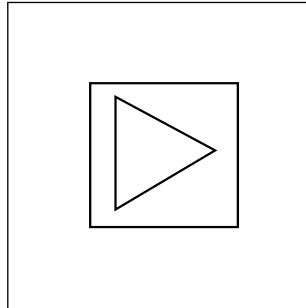

Ordering code



11

Technical data

General		
Model	Module package for snap-on mounting on EN 50022 rail	
Package material	Polycarbonate	
Inflammability class	V0 acc. UL 94	
Installation position	unrestricted	
Ambient temperature range	[°C]	-20...+60
Protection class	IP 20 acc. EN 60529	
MTTF _D value	[years]	150
Weight	[g]	160
Electrical		
Duty ratio	[%]	100
Supply voltage	[VDC]	18...30, ripple < 5 % eff., surge free ¹⁾
Current consumption max.	[A]	2.2
Pre-fusing	[A]	2.5, medium lag
Command signal	[V]	+10...0...-10, ripple < 0.01 % eff., surge free, Ri = 150 kOhm
Input signal resolution	[%]	0.025
Differential input voltage max.	[V]	30 for terminals 5 und 6 against PE (terminal 8)
Enable signal	[V]	0...4.0: Off / 9.0...30: On / Ri = 30 kOhm
Command channel signal	[V]	0...4.0: Off / 9.0...30: On / Ri = 30 kOhm
Status signal	[V]	0...0.5: Off / Us: On / rated max. 15 mA
Adjustment ranges		
Min	[%]	0...50
Max	[%]	50...100
Ramp	[s]	0...32.5
Zero offset	[%]	+100...-100
Current	[A]	0.8 / 1.3 / 1.8 / 2.7 / 3.5
Interface	RS 232C, DSub 9p. male for null modem cable	
EMC	EN 50081-2, EN 50082-2	
Connection	Screw terminals 0.2...2.5 mm ² , disconnectable	
Cable specification	[mm ²]	1.5 overall braid shield for supply voltage and solenoids (AWG16)
	[mm ²]	0.5 overall braid shield for sensor and signal (AWG20)
Cable length	[m]	50

Block diagram

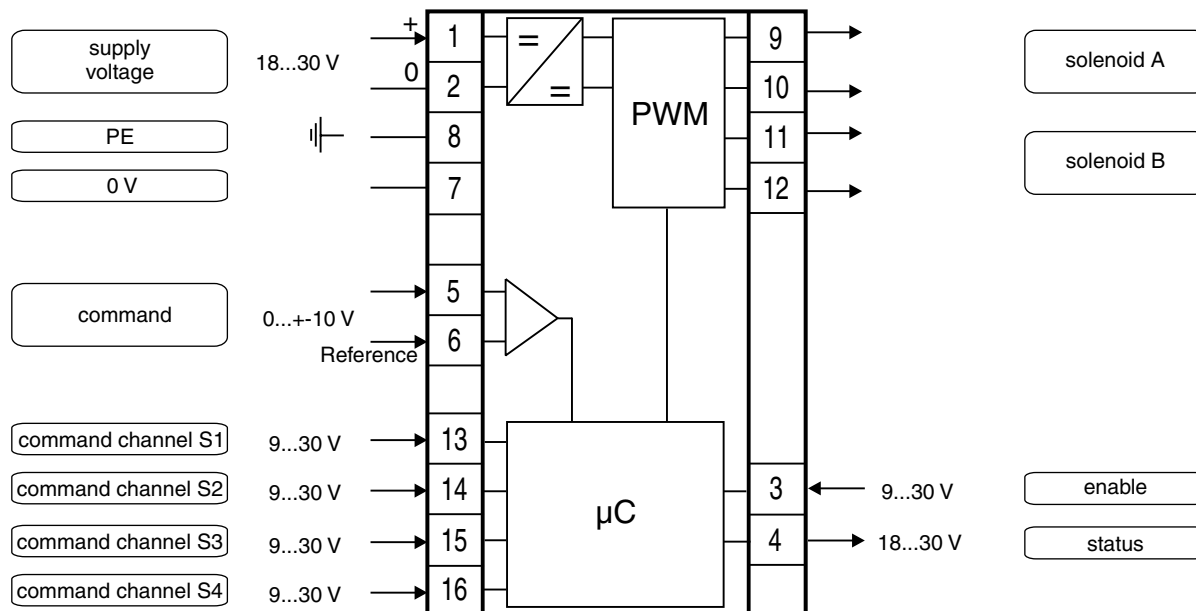

¹⁾ If solenoids with a nominal voltage of 24 V are connected, the supply voltage has to be raised to 29 V.

Signal flow diagram

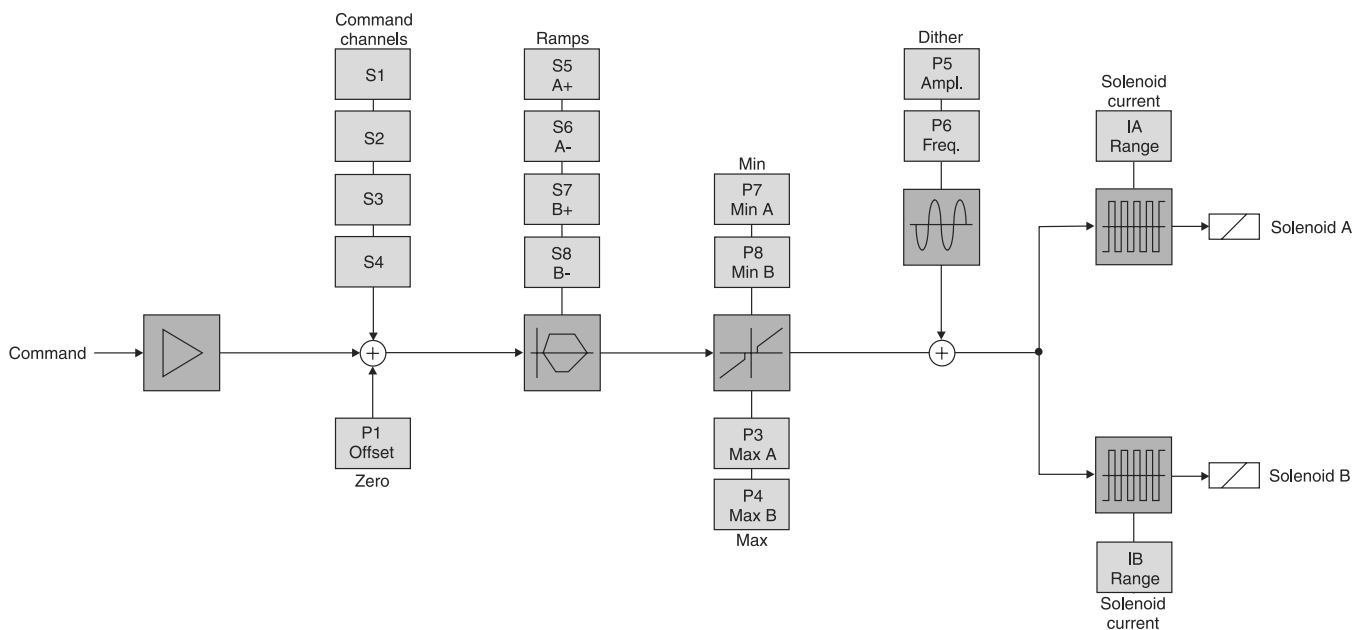

Dimensions

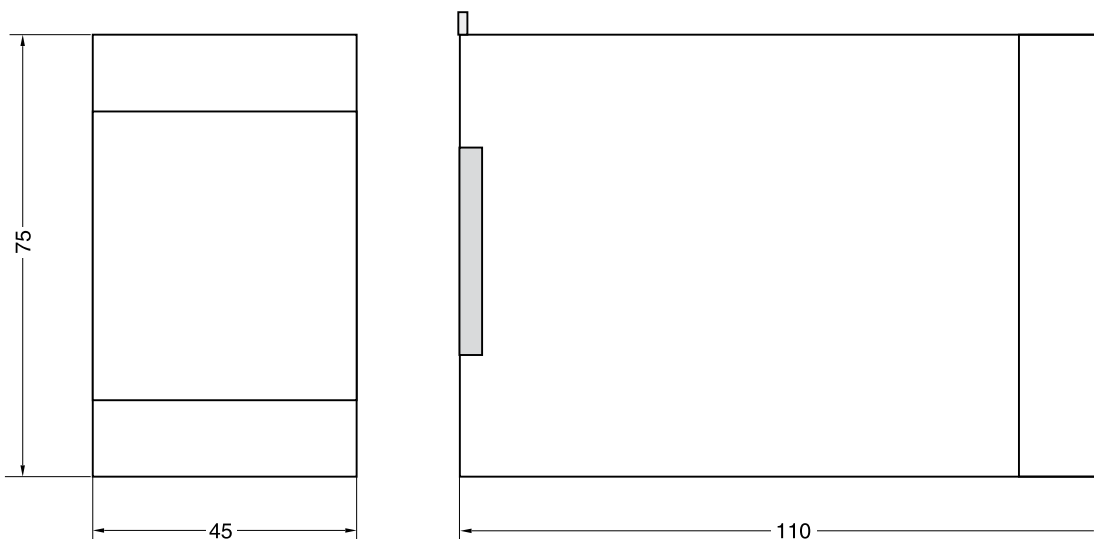

11

ProPxD interface program

The ProPxD software permits comfortable parameter setting for the module electronics. Via the clearly arranged entry mask the parameters can be monitored and modified. Storage of complete parameter sets is possible as well as printout or record as a text file for further documentation. Stored parameter sets may be loaded anytime and transmitted to other valves. Inside the electronics a nonvolatile memory stores the data with the option for recalling or modification.

The PC software can be downloaded free of charge at www.parker.com/euro_hcd – see page "Support" or directly at www.parker.com/propxd.

Features

- Comfortable editing of all parameters
- Depiction and documentation of parameter sets
- Storage and loading of optimized parameter adjustments
- Executable with all actual Windows® operating systems from Windows® XP upwards
- Plain communication between PC and electronics via serial interface RS232C

