



3L Tie-Rod Cylinders

*NFPA Hydraulic Cylinders for
working pressures up to 70 bar*

*Catalogue HY07-1130/UK
May 2003*



3L Cylinder Mounting Styles

The standard range of Parker 3L cylinders comprises 15 mounting styles, to suit the majority of applications. General guidance for the selection of the cylinders is given below, with dimensional information about each mounting style shown on pages 10 - 21 for 25.4mm to 152.4mm (1" to 6") bore sizes, and pages 22 - 29 for 203.2mm (8") bore sizes.

Application-specific mounting information is shown on pages 34 - 35.

Where a non-standard mounting style is required to satisfy a particular application, our design engineers will be happy to assist. Please contact the factory for details.

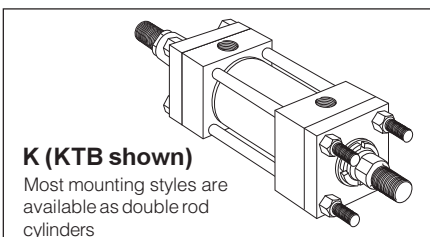
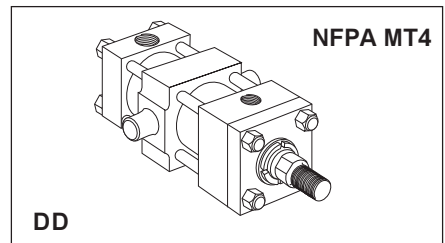
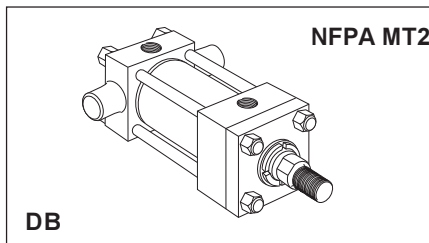
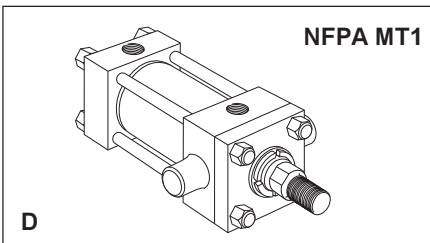
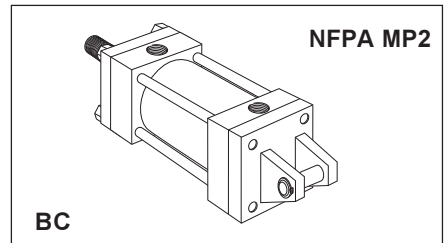
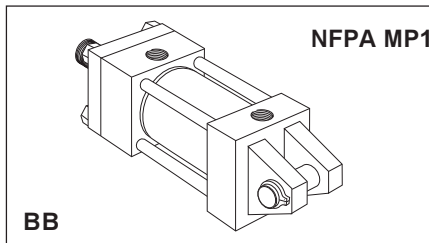
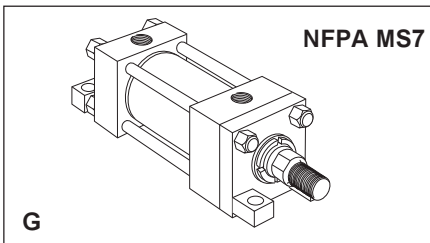
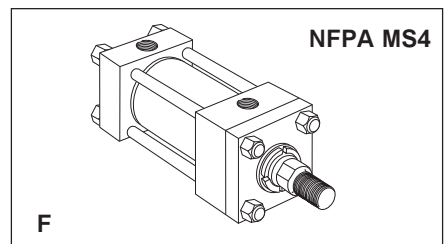
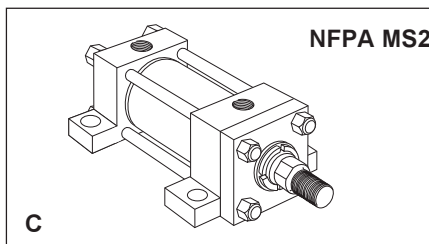
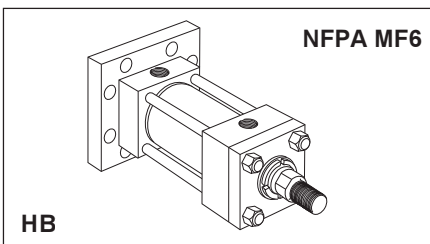
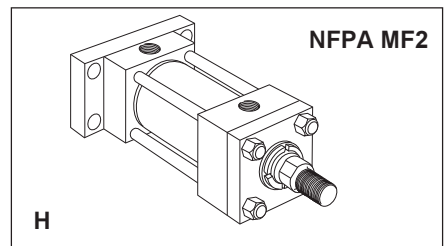
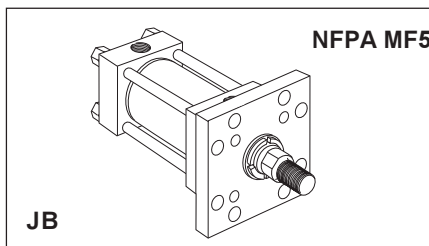
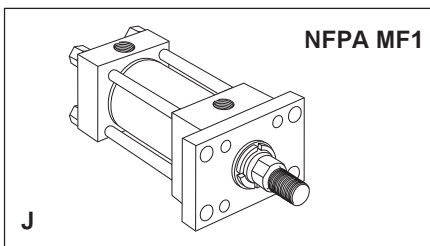
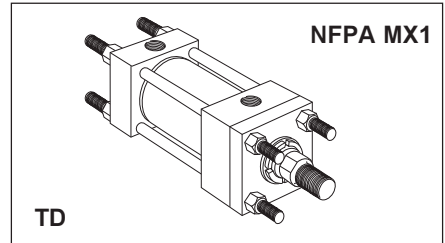
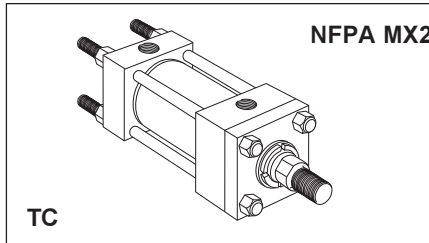
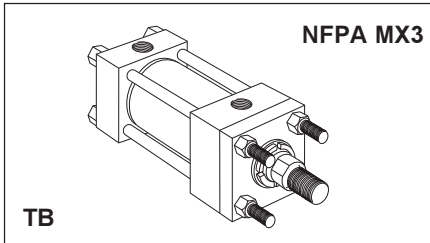

**Piston Rod End Details –
 25.4mm to 152.4mm (1" to 6") bore sizes only**

Piston Rod End Data for 203.2mm (8") bore size cylinders is shown on page 46.

Rod End Styles 4 & 8

Style 4 rod ends are recommended for all applications in which the work piece is secured against the rod shoulder. Where the work piece is not shouldered, Style 8 rod ends are recommended. If a rod end style is not specified, Style 4 will be supplied.

Rod End Style 4

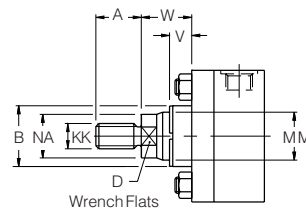

Rod End Style 8

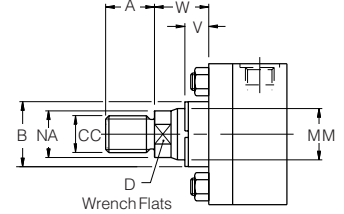

Rod End Style 9

For applications where a female thread is required.

Rod End Style 3

Non-standard piston rod ends are designated 'Style 3'. A dimensional sketch or description should accompany the order. Please specify dimensions KK or CC, and A.

Rod End Style 9

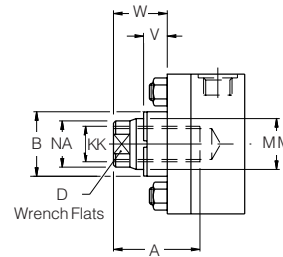

Rod End Dimensions – 25.4mm to 152.4mm (1" to 6") bore sizes only

Bore Ø	Rod No.	MM Rod Diameter	Style 4 & 9		Style 8		A	+0.00 B -0.05	D	NA	V	W
			KK Metric	KK UNF ¹	CC Metric	CC UNF ¹						
25.4 (1")	1	12.7 (1/2")	M8x1.25	5/16 - 24	M10x1.5	7/16 - 20	15.9	25.37	10	11.1	6.4	15.9
	2	15.9 (5/8")	M10x1.5	7/16 - 20	M12x1.5	1/2 - 20	19.0	28.55	13	14.3	6.4	15.9
38.1 (1 1/2")	1	15.9 (5/8")	M10x1.5	7/16 - 20	M12x1.5	1/2 - 20	19.0	28.55	13	14.3	6.4	15.9
	2	25.4 (1")	M20x1.5	3/4 - 16	M22x1.5	7/8 - 14	28.6	38.07	22	22.6	12.7	25.4
50.8 (2")	1	15.9 (5/8")	M10x1.5	7/16 - 20	M12x1.5	1/2 - 20	19.0	28.55	13	14.3	6.4	15.9
	2	34.9 (1 3/8")	M26x1.5	1 - 14	M30x2	1 1/4 - 12	41.3	50.77	30	32.2	15.9	31.8
	3	25.4 (1")	M20x1.5	3/4 - 16	M22x1.5	7/8 - 14	28.5	38.07	22	22.6	12.7	25.4
63.5 (2 1/2")	1	25.4 (1")	M20x1.5	3/4 - 16	M22x1.5	7/8 - 14	28.5	38.07	22	22.6	12.7	25.4
	2	44.5 (1 3/4")	M33x2	1 1/4 - 12	M39x2	1 1/2 - 12	50.8	60.30	36	41.6	19.1	38.1
	3	34.9 (1 3/8")	M26x1.5	1 - 14	M30x2	1 1/4 - 12	41.3	50.77	30	32.2	15.9	31.8
	7	15.9 (5/8")	M10x1.5	7/16 - 20	M12x1.5	1/2 - 20	19.0	28.55	13	14.3	6.4	15.9
82.6 (3 1/4")	1	25.4 (1")	M20x1.5	3/4 - 16	M22x1.5	7/8 - 14	28.5	38.07	22	22.6	6.4	19.1
	2	50.8 (2")	M39x2	1 1/2 - 12	M45x2	1 3/4 - 12	57.1	66.65	41	48.0	12.7	34.9
	3	34.9 (1 3/8")	M26x1.5	1 - 14	M30x2	1 1/4 - 12	41.3	50.77	30	32.2	9.5	25.4
	4	44.5 (1 3/4")	M33x2	1 1/4 - 12	M39x2	1 1/2 - 12	50.8	60.30	36	41.6	12.7	31.8
101.6 (4")	1	34.9 (1 3/8")	M26x1.5	1 - 14	M30x2	1 1/4 - 12	41.3	50.77	30	32.2	9.5	25.4
	2	63.5 (2 1/2")	M48x2	1 7/8 - 12	M56x2	2 1/4 - 12	76.2	79.35	55	60.3	15.9	41.3
	3	44.5 (1 3/4")	M33x2	1 1/4 - 12	M39x2	1 1/2 - 12	50.8	60.30	36	41.6	12.7	31.8
	4	50.8 (2")	M39x2	1 1/2 - 12	M45x2	1 3/4 - 12	57.1	66.65	41	48.0	12.7	34.9
	7	25.4 (1")	M20x1.5	3/4 - 16	M22x1.5	7/8 - 14	28.5	38.07	22	22.6	6.4	19.1
127.0 (5")	1	44.5 (1 3/4")	M33x2	1 1/4 - 12	M39x2	1 1/2 - 12	50.8	60.30	36	41.6	12.7	31.8
	2	88.9 (3 1/2")	M64x2	2 1/2 - 12	M76x2	3 1/4 - 12	88.9	107.92	75	85.7	15.9	41.3
	3	50.8 (2")	M39x2	1 1/2 - 12	M45x2	1 3/4 - 12	57.1	66.65	41	48.0	12.7	34.9
	4	63.5 (2 1/2")	M48x2	1 7/8 - 12	M56x2	2 1/4 - 12	76.2	79.35	55	60.3	15.9	41.3
	5	76.2 (3")	M58x2	2 1/4 - 12	M68x2	2 3/4 - 12	88.9	95.22	65	73.0	15.9	41.3
	7	25.4 (1")	M20x1.5	3/4 - 16	M22x1.5	7/8 - 14	28.5	38.07	22	22.6	6.4	19.1
	8	34.9 (1 3/8")	M26x1.5	1 - 14	M30x2	1 1/4 - 12	41.3	50.77	30	32.2	9.5	25.4
	152.4 (6")	1	44.5 (1 3/4")	M33x2	1 1/4 - 12	M39x2	1 1/2 - 12	50.8	60.30	36	41.6	9.5
2	101.6 (4")	M76x2	3 - 12	M95x2	3 3/4 - 12	101.6	120.62	85	98.4	12.7	38.1	
3	50.8 (2")	M39x2	1 1/2 - 12	M45x2	1 3/4 - 12	57.1	66.65	41	48.0	9.5	31.8	
4	63.5 (2 1/2")	M48x2	1 7/8 - 12	M56x2	2 1/4 - 12	76.2	79.35	55	60.3	12.7	38.1	
5	76.2 (3")	M58x2	2 1/4 - 12	M68x2	2 3/4 - 12	88.9	95.22	65	73.0	12.7	38.1	
6	88.9 (3 1/2")	M64x2	2 1/2 - 12	M76x2	3 1/4 - 12	88.9	107.92	75	85.7	12.7	38.1	
7	34.9 (1 3/8")	M26x1.5	1 - 14	M30x2	1 1/4 - 12	41.3	50.77	30	32.2	6.4	22.2	

All dimensions are in millimetres unless otherwise stated.

¹ All rod threads are UNF except 1" - 14 which is UNS.

Storage

When cylinders must be stored for a period of time, the following procedures are recommended:

1. Store the cylinders in an indoor area which has a dry, clean and non-corrosive atmosphere. Take care to protect the cylinder from both internal corrosion and external damage.
2. Whenever possible, cylinders should be stored in a vertical position (piston rod up). This will minimize corrosion due to possible condensation which could occur inside the cylinder, and seal set due to the weight of the piston and rod assembly.
3. Port protector plugs should be left in the cylinder until the time of installation.
4. For long duration storage add a vapour phase inhibitor to both sides of the piston to prevent internal corrosion.

Installation

1. Cleanliness is an important consideration, and Parker cylinders are shipped with the ports plugged to protect them from contaminants entering the ports. These plugs should not be removed until the piping is to be installed. Before making the connection to the cylinder ports, piping should be thoroughly cleaned to remove all chips or burrs which might have resulted from threading or flaring operations.
2. Cylinders operating in an environment where air drying materials are present such as fast-drying chemicals, paint, or weld splatter, or other hazardous conditions such as excessive heat, should have shields installed to prevent damage to the piston rod and piston rod seals.
3. Correct alignment of the cylinder piston rod and its mating component on the machine should be checked in both the extended and retracted positions. Incorrect alignment will result in excessive rod gland and/or cylinder bore wear, shortening the life of the cylinder.

Warranty

Defective Work or Material Every effort is made to ensure sound material and good workmanship, but the Seller gives no warranty, expressed or implied, of material, workmanship, or fitness of goods for any particular purpose, whether such purpose be known to the Seller or not. In the event of any material or workmanship proving defective the Seller is prepared to rectify or replace such material at the place of delivery and in the condition originally specified, or if rectification or replacement is not practicable, will credit the value of the goods at the invoice price, if required in writing to do so, provided always that the claim is made and admitted and the material is returned within six months from date of invoice. The Seller's liability in respect of or consequent upon any such defect whether in original or replaced material or workmanship, is limited as aforesaid and does not extend in any circumstances to cover any other expenditure incurred nor any consequential damages or loss of profit.

Masses – Series 3L Cylinders

To determine the mass of the cylinder, first select the basic mass for zero stroke, then calculate the mass for the cylinder stroke and add the result to the basic mass.

Bore Ø	Rod No.	Single Rod Cylinders			Double Rod Cylinders		
		Mass at Zero Stroke		Mass per 10mm stroke (kg)	Mass at Zero Stroke		Mass per 10mm stroke (kg)
		Mounting Styles			Mounting Styles		
		TB, TC, TD, J, JB, H, HB, F (kg)	C, G, BB, BC, D, DB, DD (kg)	TB, TD, J, JB, F (kg)	C, G, D, DD (kg)		
25.4 (1")	1	1.2	1.3	0.04	1.5	1.7	0.05
	2	1.2	1.4	0.04	1.6	1.9	0.06
38.1 (1½")	1	1.9	2.2	0.05	2.4	2.9	0.07
	2	2.2	2.6	0.08	2.9	3.7	0.12
50.8 (2")	1	3.0	3.4	0.07	3.7	4.4	0.08
	2	3.6	4.3	0.13	4.8	6.2	0.20
	3	3.2	3.5	0.09	4.0	4.8	0.13
63.5 (2½")	1	4.5	4.9	0.10	5.7	6.5	0.14
	2	5.5	6.7	0.18	7.6	10.1	0.30
	3	4.9	5.6	0.14	6.4	7.8	0.21
	7	4.4	4.6	0.08	5.4	5.9	0.09
82.6 (3¼")	1	8.3	9.0	0.12	10.5	11.8	0.16
	2	9.6	11.5	0.24	13.0	16.8	0.40
	3	8.6	9.6	0.16	11.0	12.9	0.23
	4	9.1	10.6	0.20	12.1	15.0	0.32
101.6 (4")	1	12.2	13.2	0.17	15.6	17.5	0.25
	2	14.6	17.9	0.34	21.0	28.0	0.59
	3	12.7	14.2	0.22	16.6	19.5	0.34
	4	13.2	15.0	0.26	17.5	21.3	0.41
127.0 (5")	7	11.9	12.5	0.14	15.0	16.3	0.18
	1	19.3	21.1	0.25	25	29	0.37
	2	24.6	32.0	0.61	36	50	1.10
	3	19.7	22.0	0.29	26	31	0.45
152.4 (6")	4	21.2	24.9	0.38	29	36	0.62
	5	22.9	28.3	0.49	32	43	0.84
	7	18.5	19.5	0.17	23	25	0.21
	8	18.8	20.0	0.21	24	27	0.28
203.2 (8")	1	29.9	32	0.28	38	42	0.40
	2	38	48	0.79	54	73	1.50
	3	31	35	0.32	39	48	0.47
	4	32	38	0.40	42	54	0.65
203.2 (8")	5	34	41	0.51	45	60	0.87
	6	35	44	0.64	48	66	1.20
	7	30	33	0.23	37	44	0.31
	1	53	59	0.51	66	78	0.67
	2	72	98	1.60	105	156	2.80
	3	54	61	0.60	68	83	0.85
	4	56	65	0.71	72	90	1.10
	5	57	68	0.84	75	96	1.40
6	60	73	1.00	80	107	1.60	
203.2 (8")	7	52	57	0.43	64	74	0.50
	8	52	58	0.47	65	76	0.60
0	67	88	1.40	95	137	2.40	

Masses for accessories are shown on pages 31 to 33.

All dimensions are in millimetres unless otherwise stated.



Contents	Page	Index	Page
Piston Rod End Data – 25.4mm to 152.4mm (1" to 6") bore sizes	3	Accessories	31 - 33
Storage Information and Cylinder Mass Data	4	Air Bleeds	7, 41, 43
Warranty	4	Cushioning	39
Introduction	5	Cylinder Masses	4, 31 - 33
Standard Specifications	5	Cylinder Selection Check List	8
Design Features and Benefits	6	Design Features	6 - 7
Cylinder Selection Check List	8	Double Rod Cylinders	30
Mounting Styles	9	Forces – Push and Pull	36
Double Rod Cylinders	30	inPHorm	5
Accessories	31	Model Numbers	47
Mounting Information	34	Mounting Styles and Information	2, 9, 34 - 35
Push and Pull Forces	36	Optional Features	43
Piston Rod Sizes and Stop Tubes	37	Ordering Instructions	47
Stroke Factors and Long Stroke Cylinders	38	Piston Rod End Data	3, 46
Cushioning	39	Piston Rod Size Selection	37
Pressure Limitations	40	Piston and Seal Types	7, 42
Ports, Locations and Piston Speeds	41	Ports – Standard and Oversize	41
Seals and Fluids	42	Pressure Ratings and Limitations	40
Optional Features	43	Repairs	45
Replacement Parts and Service	44	Replacement Parts and Service	44 - 45
Repairs	45	Seals and Fluids	42
Piston Rod End Data – 203.2mm (8") bore sizes	46	Speed Limitations	41
How to Order Cylinders	47	Standard Specifications	5
		Stop Tubes	37
		Storage and Installation	4
		Stroke Adjusters	43
		Stroke Factors	38
		Stroke Tolerances	35
		Thrust Keys	34
		Warranty	4

Introduction

Parker Hannifin Corporation is a world leader in the manufacture of components and systems for motion control. Parker has more than 800 product lines for hydraulic, pneumatic and electro-mechanical applications in some 1200 industrial and aerospace markets. With more than 45,000 employees and some 210 manufacturing plants and administrative offices around the world, Parker provides customers with technical excellence and first class customer service. Parker Hannifin's Cylinder Division is the world's largest supplier of hydraulic cylinders for industrial applications.

The 3L cylinders described in this catalogue are 70 bar medium pressure cylinders, rated for use at working pressures up to 70 bar depending on the rod end and type of service.

In addition to the standard cylinders featured in this catalogue, 3L cylinders can be designed to suit customer requirements.

Our engineers will be pleased to advise on unique designs to suit specific applications.

inPHorm

European Cylinder inPHorm is Parker Hannifin's new product selection program that helps you to select the correct part for an application. The program prompts for the details of the application, makes the necessary design calculations, and selects a suitable product. inPHorm can generate CAD drawings of the selected part, which can be viewed in other software applications, and customised and imported into other CAD packages. Please contact your local Sales Office for further information and ask for HY07-1260/Eur.

Visit us at www.parker.com/uk

Standard Specifications

- Medium-duty service – ANSI B93.15-1987 and NFPA specifications
- Standard construction – square end, 4 tie rod design
- Standard pressure – to 70 bar (1000 psi) dependent on bore size
- Standard fluid – hydraulic mineral oil
- Standard temperature – -20°C to +80°C (-4°F to +176°F)
- Bore sizes – 25.4mm (1") to 203.2mm (8")
- Piston rod diameters – 12.7mm (1/2") to 139.7mm (5 1/2")
- Mounting styles – 15 standard styles
- Strokes – available in any practical stroke length
- Cushions – optional at either end or both ends of stroke
- Rod ends – three standard choices – specials to order
- Tested in accordance with ISO 10100:2001

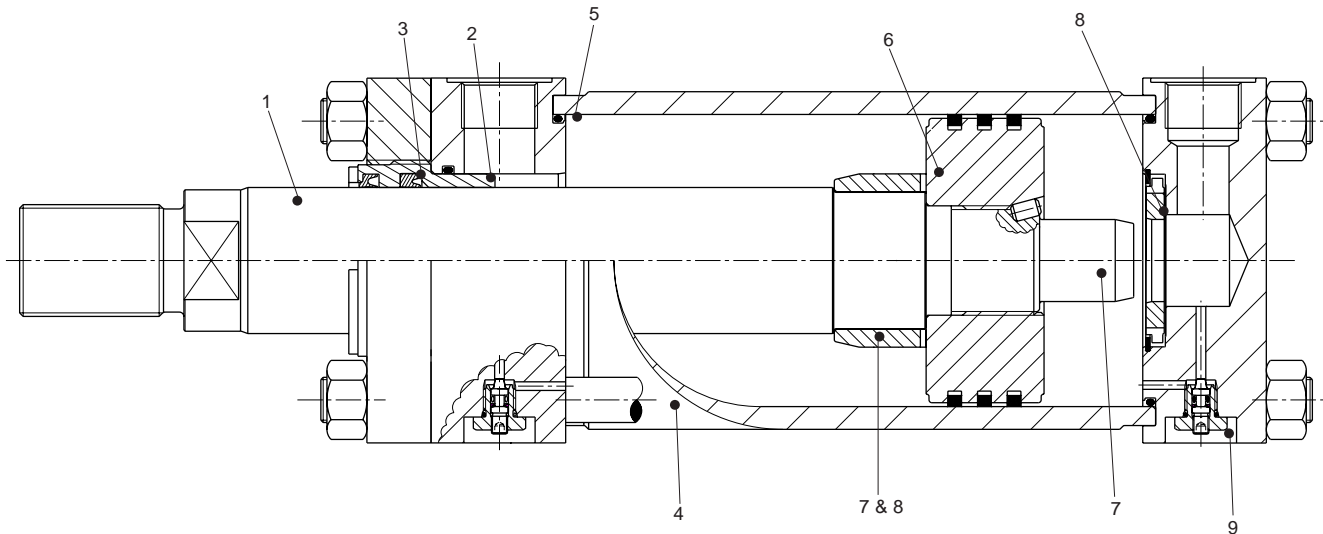

1 Piston Rod

Gland seal life is maximised by manufacturing piston rods from precision ground, high tensile carbon alloy steel, hard chrome plated and polished to 0.2µm max. Piston rods are induction case hardened to Rockwell C54 minimum before chrome plating, resulting in a dent-resistant surface.

2 Parker's Rod Gland

Continuous lubrication, and therefore longer gland life, are provided by the long bearing surface inboard of the lipseal. The gland, complete with rod seals, can easily be removed without dismantling the cylinder, so servicing is quicker – and therefore more economical.

3 Rod Seals

The serrated lipseal has a series of sealing edges which take over successively as pressure increases, providing efficient sealing under all operating conditions. On the return stroke the serrations act as a check valve, allowing the oil adhering to the rod to pass back into the cylinder.

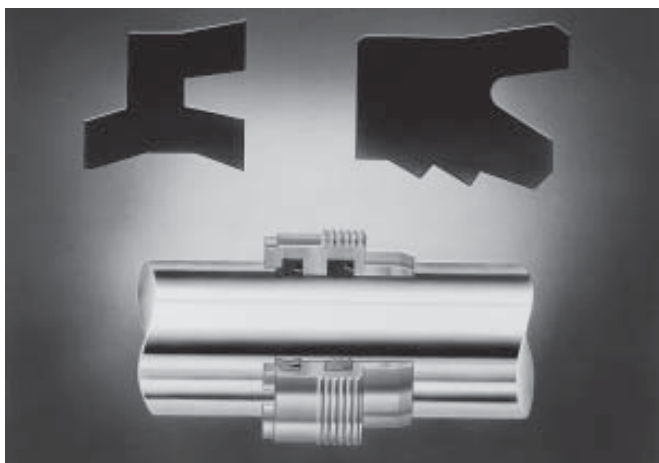

The double lip wiperseal acts as a secondary seal, trapping excess lubricating film in the chamber between the wiper and lip seals. Its outer lip prevents the ingress of dirt into the cylinder, extending the life of gland and seals.

Standard lipseals are manufactured from an enhanced polyurethane, giving efficient retention of pressurized fluid and a

service life of up to five times that of traditional seal materials. Standard seals are suitable for speeds of up to 0.5m/s – special seal combinations including PTFE are available for higher speed applications.

4 Cylinder Body

Strict quality control standards and precision manufacture ensure that all tubes meet rigid standards of straightness, roundness and surface finish. The steel tubing is surface finished to minimise internal friction and prolong seal life.

5 Cylinder Body Seals

To ensure that the cylinder body remains leak free, even under pressure shock conditions, Parker fits pressure-energised body seals.

6 Piston

Wear-resistant cast iron piston rings are fitted as standard to 3L cylinders. Lipseal pistons are available to suit different applications – see 'Piston Seals' opposite. All pistons are of one-piece type, and feature wide bearing surfaces to resist side loading. Long thread engagement secures the piston to the piston rod and, for additional safety, the piston is secured by thread-locking adhesive and a locking pin.

7 Cushioning

Deceleration of a load attached to the piston rod is achieved by using 'built-in' cushions at either or both ends of the cylinder – see page 39 for details. At the head end a cushion sleeve is fitted, while the polished cap end spear is an integral part of the piston rod.

8 Floating Cushion Bushes & Sleeves

Closer tolerances – and therefore more effective cushioning – are permitted by the use of a floating cushion sleeve at the head end of the cylinder, and a floating cushion bush at the cap end. A specially designed cushion sleeve on bore sizes up to 101.6mm (4") operates as a check valve. On larger bore sizes a conventional ball check valve is used. The use of a check valve in the head and lifting of the bronze cushion bush in the cap, provides minimum fluid flow restriction at the start of the return stroke. This allows full pressure to be applied over the whole area of the piston, to provide full power and fast cycle times.

9 Cushion Adjustment

Needle valves are provided at both ends of the cylinder for precise cushion adjustment, and retained within the head and cap so that they cannot be inadvertently removed. The cartridge type needle valve illustrated below is fitted to cylinders of up to 63.5mm (2½") bore – see page 41.

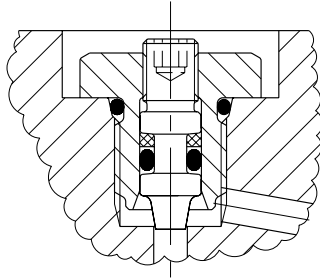

Air Bleeds

Available as an option at both ends, the air bleeds are recessed into the head and cap and retained so that they cannot be inadvertently removed – see pages 41 and 43.

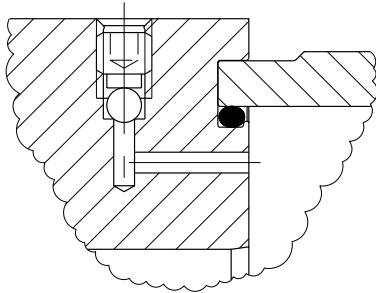

Special Designs

Parker's design and engineering staff are available to produce special designs to meet customer's specific requirements. Alternative sealing arrangements, special mounting styles, different bores and rod sizes are just a few of the custom features which can be supplied.

Piston Seals

A variety of piston seal options is available, to suit different applications. The seal option should be specified at the time of order as a seal type cannot be changed unless the piston is also changed.

Cast Iron Piston Rings are extremely durable but allow some leakage across the piston and cannot therefore hold a load in position. Piston rings are fitted as standard on series 3L hydraulic cylinders.

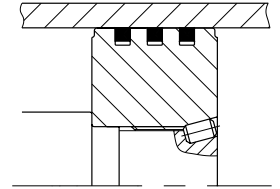

Lipseal Pistons can hold a load in position, but they are not as durable as piston rings. Lipseal pistons are optional on series 3L hydraulic cylinders.

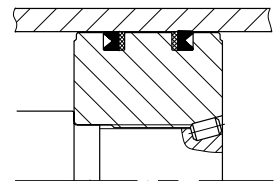

Seal Groups

To accommodate the many types of fluid and the varying temperature ranges used in industry, Parker offers a range of rod gland, piston and body seals moulded in different profiles and from different materials. These are described in detail on page 42.

Check List

The following check list indicates the principal factors which should be considered when selecting a hydraulic cylinder for a particular application. Further information is available on the pages shown. If more detailed information is required about any aspect of a cylinder's specification, please contact our design engineers who will be happy to assist.

inPHorm

The European cylinder inPHorm program can assist with the selection and specification of an hydraulic cylinder for a particular application. Please ask for HY07-1260/Eur.

- 1 Establish System Parameters** **Series 3L**

 - Weight to be moved and force required
 - Nominal operating pressure and range
 - Distance to be travelled
 - Average and maximum piston speed
 - Fluid medium and temperature
- 2 Mounting Style** **Page 9**

Select the appropriate style for the specific application
- 3 Cylinder Bore and Operating Pressure** **Pages 36, 40**

Determine the bore and system pressure required to provide the necessary force
- 4 Piston Rod** **Pages 3, 30, 37, 40, 46**

 - Single or double rod?
 - Determine the minimum rod diameter required to withstand buckling forces
 - Is a stop tube required?
 - Select a suitable rod end and rod end thread
 - Check pressure rating of selected cylinder and piston rod
- 5 Piston** **Page 7**

Does seal type suit application?
- 6 Cushioning** **Page 39**

Select cushioning requirements if applicable
- 7 Ports** **Page 41**

 - Select suitable ports
 - Are they capable of the speed required?
 - Are the standard positions acceptable?
- 8 Seals** **Pages 7, 42**

 - Select seals to suit the chosen fluid medium and temperature range
- 9 Rod and Cap End Accessories** **Pages 31-33**

Are rod end and/or cap end accessories required?
- 10 Optional Features** **Page 43**

 - Air bleeds, rod end bellows etc.

Cylinder Mounting Styles

The standard range of Parker 3L cylinders comprises 15 mounting styles, to suit the majority of applications. General guidance for the selection of cylinders is given below, with dimensional information about each mounting style shown on the pages indicated. Application-specific mounting information is shown on pages 34 and 35.

Where a non-standard mounting style is required to satisfy a particular application, our design engineers will be happy to assist. Please contact the factory for details.

Extended Tie Rods

Cylinders with TB, TC and TD mountings are suitable for straight line force transfer applications, and are particularly useful where space is limited. For compression (push) applications, cap end tie rod mountings are most appropriate; where the major load places the piston rod in tension (pull applications), head end mounting styles should be specified. Cylinders with tie rods extended at both ends may be attached to the machine member from either end, allowing the free end of the cylinder to support a bracket or switch.

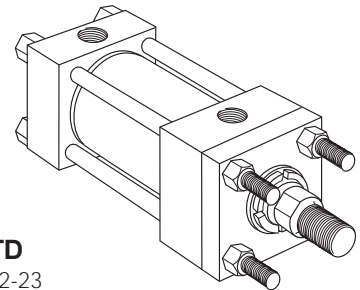

Styles TB, TC, TD
See pages 10-11, 22-23

TB

Flange Mounted Cylinders

Flange mounted cylinders are also suitable for use on straight line force transfer applications. Four flange mounting styles are available: head rectangular flange (J), head square flange (JB), cap rectangular flange (H), and cap square flange (HB). Selection of the correct flange mounting style depends on whether the major force applied to the load will result in compression (push) or tension (pull) stresses on the piston rod.

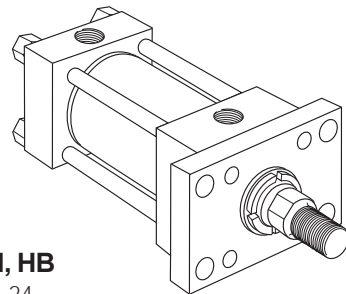

Styles J, JB, H, HB
See pages 12-15, 24

J

Foot Mounted Cylinders

Foot mounted cylinders do not absorb force on their centreline. As a result, the application of force by the cylinder produces a turning moment which attempts to rotate the cylinder about its mounting bolts. It is important, therefore, that the cylinder should be firmly secured to the mounting surface and that the load should be effectively guided, to avoid side loads being applied to rod gland and piston bearings. A thrust key modification may be specified to provide positive cylinder location – see page 34.

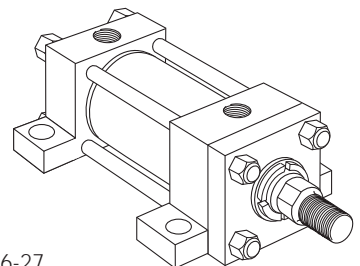

Styles C, F, G
See pages 16-17, 26-27

C

Pivot Mountings

Cylinders with pivot mountings, which absorb forces on their centrelines, should be used where the machine member to be moved travels in a curved path. Pivot mountings may be used for tension (pull) or compression (push) applications. Two pivot mounting styles are available: cap fixed clevis (BB), and cap detachable clevis (BC). These styles may be used if the curved path of the piston rod travel is in a single plane, and perpendicular to the cylinder pivot axis (one degree of freedom).

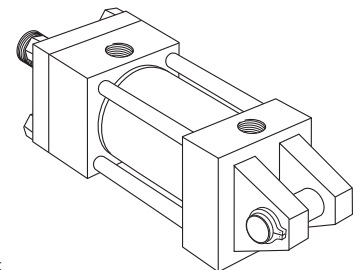

Styles BB, BC
See pages 18-19, 25

BB

Trunnion Mounted Cylinders

These cylinders are designed to absorb force on their centrelines. They are suitable for tension (pull) or compression (push) applications, and may be used where the machine member to be moved travels in a curved path in a single plane. Trunnion mounted cylinders are available in head trunnion (D), cap trunnion (DB), and intermediate fixed trunnion (DD). Trunnion pins are designed for shear loads only and should be subjected to minimum bending stresses.

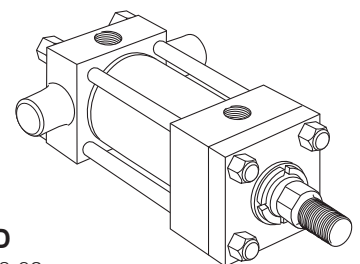

Styles D, DB, DD
See pages 20-21, 28-29

DB

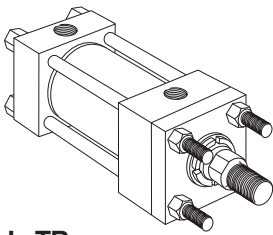

Style TB

Tie Rods Extended Head End
(NFPA Style MX3)

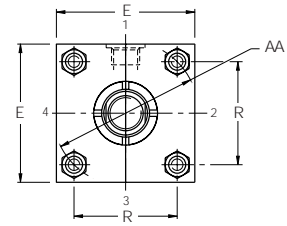
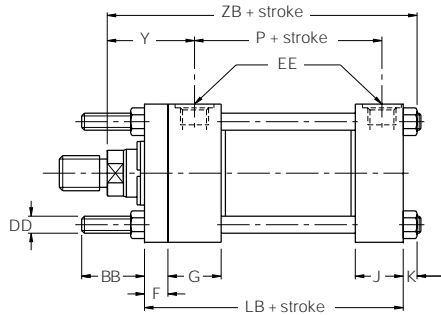

See Notes 1, 2, 3, 4, 5, 6

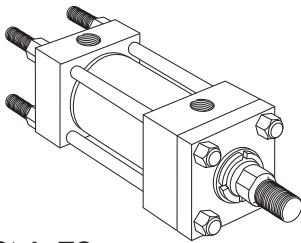

Style TC

Tie Rods Extended Cap End
(NFPA Style MX2)

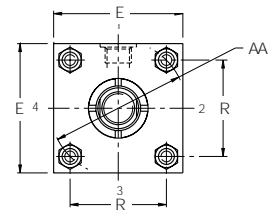
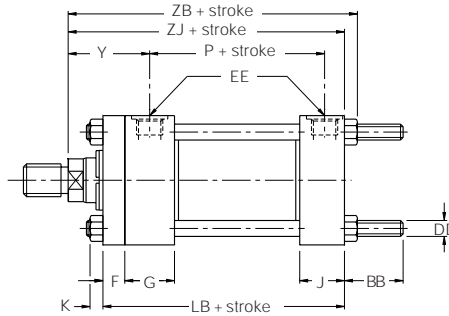

See Notes 1, 2, 3, 4, 5, 6

Dimensions TB, TC & TD See also Dimensions, page 3 & Mounting Information, pages 9 & 34

Bore Ø	Rod No.	AA	BB	DD ²	E	EE ⁶ (BSPP)	F	G	H ⁵
25.4 (1")	1	38.9	19.1	10-24	38.1 ⁵	G ¹ / ₄	9.5	38.1	6.4
	2								
38.1 (1½")	1	51.3	25.4	¼ - 28	50.8 ⁵	G ³ / ₈	9.5	38.1	-
	2								3.2
50.8 (2")	1	66.2	28.6	5/16 - 24	63.5 ⁵	G ³ / ₈	9.5	38.1	-
	2								2.4
	3								-
63.5 (2½")	1	78.5	28.6	5/16 - 24	76.2 ⁵	G ³ / ₈	9.5	38.1	2.4
	2								-
	3								2.4
	7								-
82.6 (3¼")	1	99.1	34.9	¾ - 24	95.2	G ¹ / ₂	15.9	44.5	-
	2								-
	3								-
	4								-
101.6 (4")	1	119.4	34.9	¾ - 24	114.3	G ¹ / ₂	15.9	44.5	-
	2								-
	3								-
	4								-
	7								-
127.0 (5")	1	147.2	46.0	½ - 20	139.7	G ¹ / ₂	15.9	44.5	-
	2								-
	3								-
	4								-
	5								-
	7								-
	8								-
	152.4 (6")								1
2		-							
3		-							
4		-							
5		-							
6		-							
7		-							

All dimensions are in millimetres unless otherwise stated.

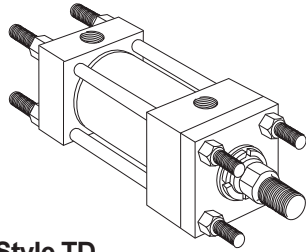

Style TD
Tie Rods Extended Both Ends
(NFAA Style MX1)

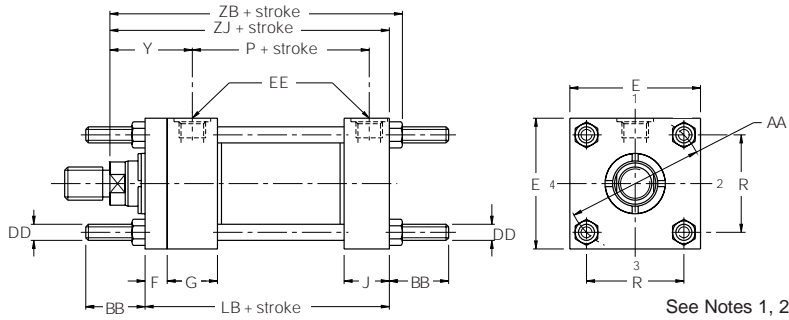

See Notes 1, 2, 3, 4, 5, 6

Notes

- 1 All cylinders are subject to maximum pressure ratings – see page 40.
- 2 All tie rod threads (dimension DD) are UNF, with the exception of 25.4mm (1") bore which is UNC.
- 3 Mounting nuts should be tightened to the torque values shown for tie rod nuts – see page 35.
- 4 For Styles TB and TC an additional set of mounting nuts are supplied. For Style TD, two additional sets of mounting nuts are supplied.
- 5 The extra height 'H' of the port face applies to the head end of the bore and rod sizes shown in the table below and to the cap end of 38.1mm (1½") bore cylinders only.
- 6 R1 size BSPP ports to ISO 228/1 are supplied as standard on 3L cylinders. For smaller R2 size ports, see page 41.

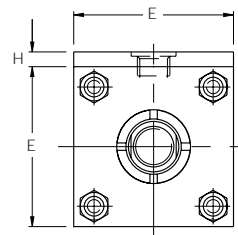

Dimensions TB, TC & TD Continued

Bore Ø	Rod No.	J	K	R	Y	+ Stroke			
						LB	P	ZB max.	ZJ
25.4 (1")	1	25.4	5.0	27.4	49	98.4	54	119.3	114.3
	2							119.3	114.3
38.1 (1½")	1	25.4	6.4	36.3	49	101.6	58	123.8	117.4
	2							133.4	127.0
50.8 (2")	1	25.4	7.5	46.7	49	101.6	58	125.8	118.3
	2							141.7	134.2
	3							135.3	127.8
63.5 (2½")	1	25.4	7.5	55.6	58	104.8	61	138.4	130.9
	2							151.2	147.3
	3							144.9	137.4
	7							129.0	121.5
82.6 (3¼")	1	31.8	10.0	70.1	58	123.8	70	152.9	142.9
	2							168.8	158.8
	3							159.3	148.3
	4							165.6	155.6
101.6 (4")	1	31.8	10.0	84.3	65	123.8	70	159.3	149.3
	2							175.1	165.1
	3							165.6	155.6
	4							168.8	158.8
	7							152.9	142.9
127.0 (5")	1	31.8	13.0	104.1	71	130.2	77	174.9	161.9
	2							184.0	171.0
	3							178.1	165.1
	4							184.5	171.5
	5							184.5	171.5
	7							162.2	149.2
152.4 (6")	1	38.1	13.0	123.9	74	146.1	83	187.6	174.6
	2							197.2	184.2
	3							191.8	178.8
	4							197.2	184.2
	5							197.2	184.2
	6							197.2	184.2
	7							181.3	168.3

All dimensions are in millimetres unless otherwise stated.

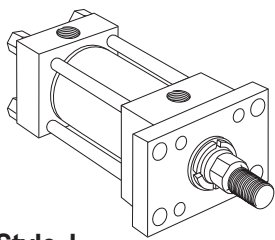

Style J
Head Rectangular Flange
(NFA Style MF1)

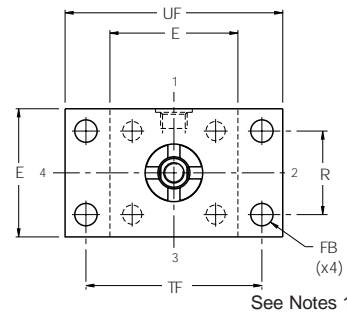
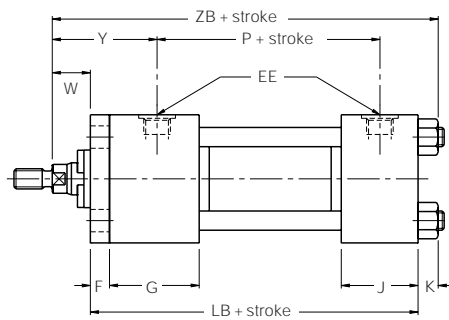

See Notes 1, 2, 3

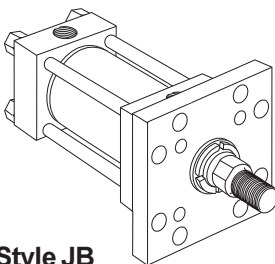

Style JB
Head Square Flange
(NFA Style MF5)

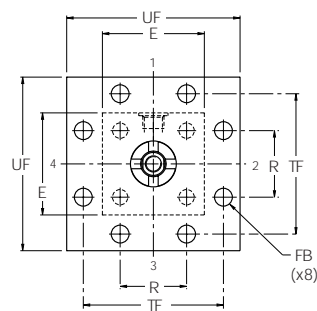
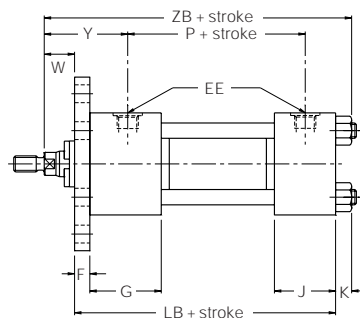

See Notes 1, 2, 3

Dimensions J & JB See also Dimensions, page 3 & Mounting Information, pages 9 & 34

Bore Ø	Rod No.	E	EE ³ (BSPP)	F	FB	G	H ²	J	K
25.4 (1")	1	38.1 ²	G ¹ / ₄	9.5	6.4	38.1	6.4	25.4	5.0
	2								
38.1 (1½")	1	50.8 ²	G ³ / ₈	9.5	7.9	38.1	-	25.4	6.4
	2								
50.8 (2")	1	63.5 ²	G ³ / ₈	9.5	9.5	38.1	2.4	25.4	7.5
	2								
	3								
63.5 (2½")	1	76.2 ²	G ³ / ₈	9.5	9.5	38.1	2.4	25.4	7.5
	2								
	3								
	7								
82.6 (3¼")	1	95.2	G ¹ / ₂	15.9	11.1	44.5	-	31.8	10.0
	2								
	3								
	4								
101.6 (4")	1	114.3	G ¹ / ₂	15.9	11.1	44.5	-	31.8	10.0
	2								
	3								
	7								
127.0 (5")	1	139.7	G ¹ / ₂	15.9	14.2	44.5	-	31.8	13.0
	2								
	3								
	4								
	5								
	8								
152.4 (6")	1	165.1	G ³ / ₄	19.1	14.2	50.8	-	38.1	13.0
	2								
	3								
	4								
	5								
	6								
	7								

All dimensions are in millimetres unless otherwise stated.

Notes

- 1 All cylinders are subject to maximum pressure ratings – see page 40.
- 2 The extra height 'H' of the port face applies to the head end of the bore and rod sizes shown in the table below and to the cap end of 38.1mm (1½") bore cylinders only.
- 3 R1 size BSPP ports to ISO 228/1 are supplied as standard on 3L cylinders. For smaller R2 size ports, see page 41.

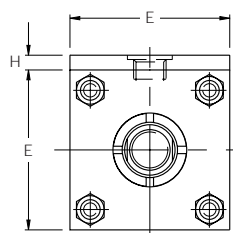

Dimensions J & JB Continued

Bore Ø	Rod No.	R	TF	UF	W	Y	+ Stroke		
							LB	P	ZB max.
25.4 (1")	1	27.4	50.8	63.5	15.9	49	98.4	54	119.3
	2								119.3
38.1 (1½")	1	36.3	69.8	85.7	15.9	49	101.6	58	123.8
	2								133.4
50.8 (2")	1	46.7	85.7	104.7	15.9	49	101.6	58	125.8
	2								141.7
	3								135.3
63.5 (2½")	1	55.6	98.4	117.4	25.4	58	104.8	61	138.4
	2								151.2
	3								144.9
	7								129.0
82.6 (3¼")	1	70.1	119.0	139.7	19.1	58	123.8	70	152.9
	2								168.8
	3								159.3
	4								165.6
101.6 (4")	1	84.3	138.1	158.7	25.4	65	123.8	70	159.3
	2								175.1
	3								165.6
	4								168.8
	7								152.9
127.0 (5")	1	104.1	168.2	193.7	31.8	71	130.2	77	174.9
	2								184.0
	3								178.1
	4								184.5
	5								184.5
	7								162.2
	8								168.6
	152.4 (6")								1
2		197.2							
3		191.8							
4		197.2							
5		197.2							
6		197.2							
7		181.3							

All dimensions are in millimetres unless otherwise stated.

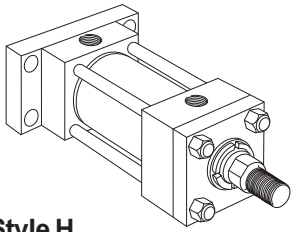

Style H
Cap Rectangular Flange
(NFA Style MF2)

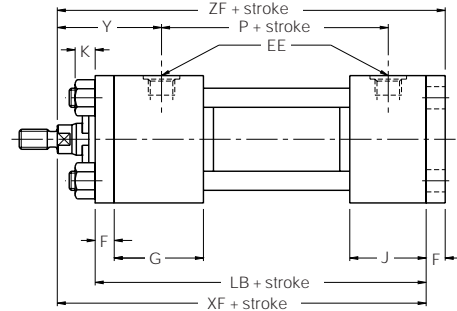
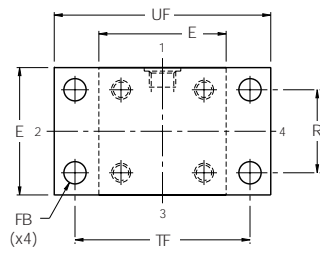

See Notes 1, 2, 3

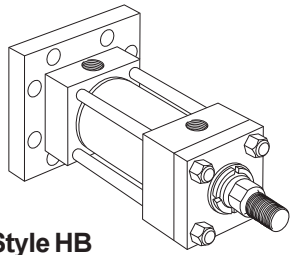

Style HB
Cap Square Flange
(NFA Style MF6)

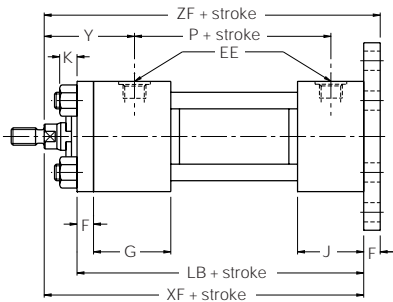
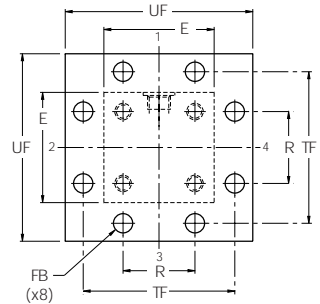

See Notes 1, 2, 3

Dimensions H & HB See also Dimensions, page 3 & Mounting Information, pages 9 & 34

Bore Ø	Rod No.	E	EE ³ (BSPP)	F	FB	G	H ²	J	K
25.4 (1")	1	38.1 ²	G ¹ / ₄	9.5	6.4	38.1	6.4	25.4	5.0
	2								
38.1 (1½")	1	50.8 ²	G ³ / ₈	9.5	7.9	38.1	-	25.4	6.4
	2								
50.8 (2")	1	63.5 ²	G ³ / ₈	9.5	9.5	38.1	2.4	25.4	7.5
	2								
	3								
63.5 (2½")	1	76.2 ²	G ³ / ₈	9.5	9.5	38.1	2.4	25.4	7.5
	2								
	3								
	7								
82.6 (3¼")	1	95.2	G ¹ / ₂	15.9	11.1	44.5	-	31.8	10.0
	2								
	3								
	4								
101.6 (4")	1	114.3	G ¹ / ₂	15.9	11.1	44.5	-	31.8	10.0
	2								
	3								
	4								
	7								
127.0 (5")	1	139.7	G ¹ / ₂	15.9	14.2	44.5	-	31.8	13.0
	2								
	3								
	4								
	5								
	7								
152.4 (6")	1	165.1	G ³ / ₄	19.1	14.2	50.8	-	38.1	13.0
	2								
	3								
	4								
	5								
	6								
	7								

All dimensions are in millimetres unless otherwise stated.

Notes

- 1 All cylinders are subject to maximum pressure ratings – see page 40.
- 2 The extra height 'H' of the port face applies to the head end of the bore and rod sizes shown in the table below and to the cap end of 38.1mm (1½") bore cylinders only.
- 3 R1 size BSPP ports to ISO 228/1 are supplied as standard on 3L cylinders. For smaller R2 size ports, see page 41.

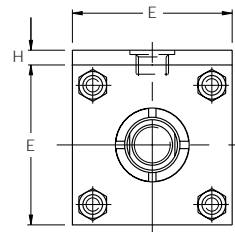

Dimensions H & HB Continued

Bore Ø	Rod No.	R	TF	UF	Y	+ Stroke			
						LB	P	XF	ZF
25.4 (1")	1	27.4	50.8	63.5	49	98.4	54	114.3	123.8
	2				49			114.3	123.8
38.1 (1½")	1	36.3	69.8	85.7	49	101.6	58	117.5	127.0
	2				58			127.0	136.5
50.8 (2")	1	46.7	85.7	104.7	49	101.6	58	117.5	127.0
	2				65			133.4	142.9
	3				58			127.0	136.5
63.5 (2½")	1	55.6	98.4	117.4	58	104.8	61	130.2	139.7
	2				71			142.9	152.4
	3				65			136.5	146.1
	7				49			120.7	130.2
82.6 (3¼")	1	70.1	119.0	139.7	58	123.8	70	142.9	158.8
	2				74			158.8	174.6
	3				65			149.2	165.1
	4				71			155.6	171.5
101.6 (4")	1	84.3	138.1	158.7	65	123.8	70	149.2	165.1
	2				81			165.1	181.0
	3				71			155.6	171.5
	4				74			158.8	174.6
	7				58			142.9	158.8
127.0 (5")	1	104.1	168.2	193.7	71	130.2	77	161.9	177.8
	2				81			171.5	187.3
	3				74			165.1	181.0
	4				81			171.5	187.3
	5				81			171.5	187.3
	7				58			149.2	165.1
	8				65			155.6	171.5
	7				68			168.3	187.3
152.4 (6")	1	123.9	193.7	219.1	74	146.1	83	174.6	193.7
	2				84			184.2	203.2
	3				78			177.8	196.9
	4				84			184.2	203.2
	5				84			184.2	203.2
	6				84			184.2	203.2
	7				68			168.3	187.3

All dimensions are in millimetres unless otherwise stated.

See Notes 1, 2, 4, 6, 7, 8

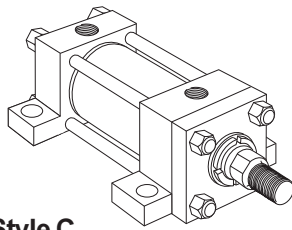

Style C
Side Lug Mounting
(NFPA Style MS2)

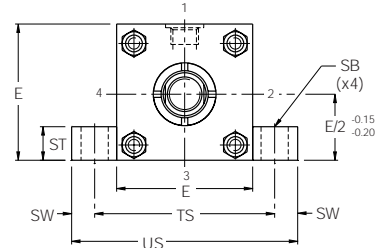
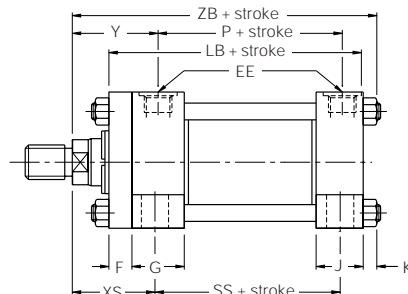

See Notes 1, 2, 3, 7, 8

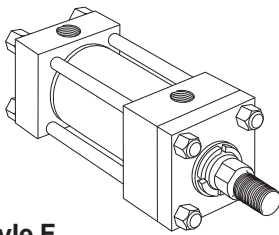

Style F
Side Tapped Mounting
(NFPA Style MS4)

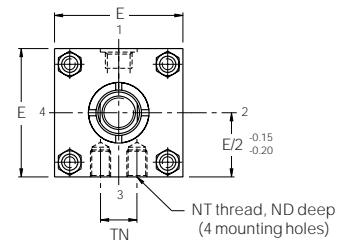
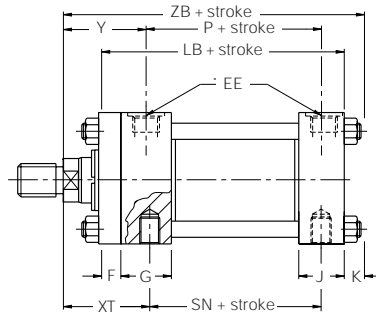

Dimensions C, F & G See also Dimensions, page 3 & Mounting Information, pages 9 & 34

Bore Ø	Rod No.	E	EB	EE ⁸ (BSPP)	EL	EO	ES	ET	F	G	H ⁷	J	K	ND	NT ³	R	SB ⁴
25.4 (1")	1	38.1 ⁷	-	G ¹ / ₄	-	-	-	-	9.5	38.1	6.4	25.4	5.0	6.4	M5	-	6.6
	2													6.4			
38.1 (1½")	1	50.8 ⁷	9.0	G ³ / ₈	19.1	6.4	14	14.3	9.5	38.1	-	25.4	6.4	9.5	M6	36.3	11.0
	2													4.8			
50.8 (2")	1	63.5 ⁷	9.5	G ³ / ₈	23.8	7.9	16	19.1	9.5	38.1	2.4	25.4	7.5	9.5	M8	46.7	11.0
	2													9.5			
	3													9.5			
63.5 (2½")	1	76.2 ⁷	9.5	G ³ / ₈	27.0	7.9	20	22.2	9.5	38.1	2.4	25.4	7.5	12.7	M10	55.6	11.0
	2													11.1			
	3													12.7			
	7													12.7			
82.6 (3¼")	1	95.2	11.1	G ¹ / ₂	22.2	9.5	25	25.4	15.9	44.5	-	31.8	10.0	19.1	M12	70.1	14.0
	2													12.7			
	3													19.1			
	4													19.1			
101.6 (4")	1	114.3	11.1	G ¹ / ₂	25.4	9.5	32	31.8	15.9	44.5	-	31.8	10.0	19.1	M12	84.3	14.0
	2													15.9			
	3													19.1			
	4													19.1			
	7													19.1			
127.0 (5")	1	139.7	14.2	G ¹ / ₂	27.0	12.7	35	38.1	15.9	44.5	-	31.8	13.0	23.8	M16	104.1	22.0
	2													19.1			
	3													23.8			
	4													23.8			
	5													23.8			
	7													23.8			
	8													23.8			
	152.4 (6")													1			
2		22.2															
3		28.6															
4		28.6															
5		28.6															
6		28.6															
7		28.6															

All dimensions are in millimetres unless otherwise stated.

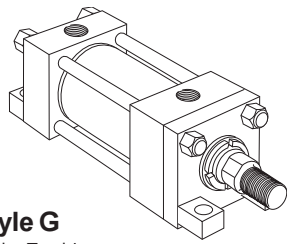

Style G
Side End Lug
(NFFPA Style MS7)

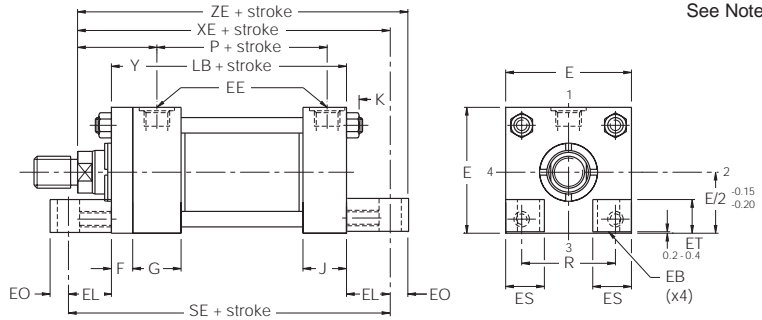

See Notes 1, 2, 5, 7, 8

Notes

- 1 All cylinders are subject to maximum pressure ratings – see page 40.
- 2 Consider the use of a thrust key with this mounting – see page 34.
- 3 Tapped mounting holes are metric (coarse pitch series).
- 4 Upper surfaces of lugs are machined for socket head screws.
- 5 Not available in 25.4mm (1") bore sizes.
- 6 Style C cylinders can be supplied with the cylinder ports arranged for mounting and sealing to a manifold surface – see page 35.
- 7 The extra height 'H' of the port face applies to the head end of the bore and rod sizes shown in the table below and to the cap end of 38.1mm (1½") bore cylinders only.
- 8 R1 size BSPP ports to ISO 228/1 are supplied as standard on 3L cylinders. For smaller R2 size ports, see page 41.

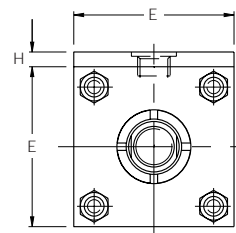

Dimensions C, F & G Continued

Bore Ø	Rod No.	ST	SW	TN	TS	US	XS	XT	Y	+ Stroke													
										LB	P	SE	SN	SS	XE	ZB max.	ZE						
25.4 (1")	1	7.9	7.9	13.5	54.0	69.9	33.3	49.2	49	98.4	54	-	54.0	73.0	-	119.3	-						
	2																	33.3	49.2	49	-	119.3	-
38.1 (1½")	1	12.7	9.5	15.5	70.0	88.9	34.9	49.2	49	101.6	58	139.7	57.2	73.0	136.5	123.8	142.9						
	2																	44.5	58.7	58	146.1	133.4	152.4
50.8 (2")	1	12.7	9.5	22.0	82.6	101.6	34.9	49.2	49	101.6	58	149.2	57.2	73.0	141.3	125.8	149.2						
	2																	50.8	65.1	65	157.2	141.7	165.1
	3																	44.5	58.7	58	150.8	135.3	158.8
63.5 (2½")	1	12.7	9.5	31.0	95.3	114.3	44.5	58.7	58	104.8	61	158.8	60.3	76.2	157.2	138.4	165.1						
	2																	57.2	71.4	71	170.0	151.2	177.8
	3																	50.8	65.1	65	163.5	144.9	171.5
	7																	34.9	49.2	49	147.6	129.0	155.6
	4																	47.6	61.9	58	165.1	152.9	174.6
82.6 (3¼")	1	19.1	12.7	38.0	120.7	146.1	63.5	77.8	74	123.8	70	168.3	66.7	82.6	181.0	168.8	190.5						
	2																	54.0	68.3	65	174.6	159.3	184.2
	3																	69.8	84.1	81	190.5	175.1	200.0
	4																	60.3	74.6	71	181.0	165.6	190.5
	7																	63.5	77.8	74	184.2	168.8	193.7
127.0 (5")	1	25.4	17.5	66.0	174.6	209.5	47.6	61.9	58	130.2	77	184.2	73.0	79.4	168.3	152.9	177.8						
	2																	65.1	77.8	74	188.9	174.9	201.6
	3																	74.6	84.1	81	198.4	184.0	211.1
	4																	68.3	77.8	74	192.1	178.1	204.8
	5																	74.6	84.1	81	198.4	184.5	211.1
	7																	74.6	84.1	81	198.4	184.5	211.1
	8																	52.4	61.9	58	176.2	162.2	188.9
	7																	58.7	68.3	65	182.6	168.6	195.3
152.4 (6")	1	25.4	17.5	80.0	200.0	235.0	65.1	77.8	74	146.1	83	196.9	79.4	92.1	200.0	187.6	212.7						
	2																	74.6	87.3	84	209.6	197.2	222.3
	3																	68.3	81.0	78	203.2	191.8	215.9
	4																	74.6	87.3	84	209.6	197.2	222.3
	5																	74.6	87.3	84	209.6	197.2	222.3
	6																	74.6	87.3	84	209.6	197.2	222.3
	7																	58.6	71.4	68	193.7	181.3	206.4

All dimensions are in millimetres unless otherwise stated.

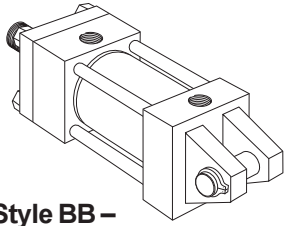

Style BB –
38.1 to 152.4mm bore sizes
 Cap Fixed Clevis
 (NFPA Style MP1)

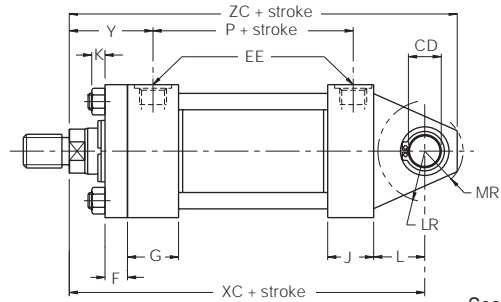
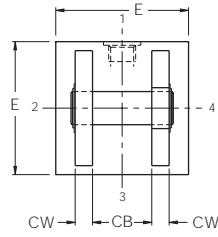

See Notes 1, 2, 5, 6

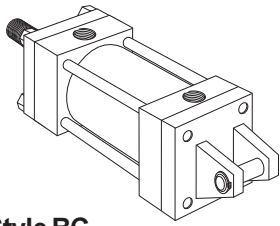

Style BC
 Cap Detachable Clevis
 (NFPA Style MP2)

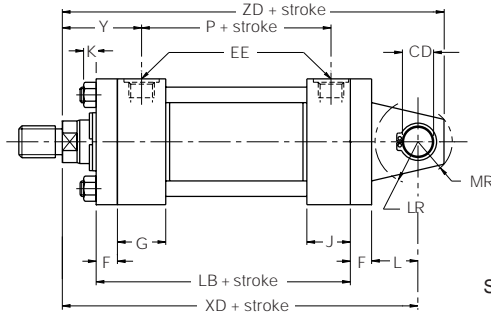
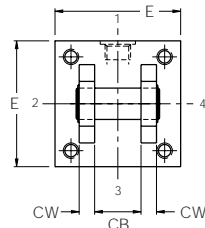

See Notes 1, 2, 3,
 4, 5, 6

Dimensions BB & BC See also Dimensions, page 3 & Mounting Information, pages 9 & 34

Bore Ø	Rod No.	CB	^{+0.00} CD _{-0.05}	CW	E	EE ⁶ (BSPP)	EW	F	G	H ⁵	J	K
25.4 (1")	1	-	11.20	-	38.1 ⁵	G ¹ / ₄	11.1	9.5	38.1	6.4	25.4	5.0
	2	-	-	-	-	-	-	-	-	-	-	-
38.1 (1½")	1	19.9	12.73	12.7	50.8 ⁵	G ³ / ₈	-	9.5	38.1	-	25.4	6.4
	2	-	-	-	-	-	-	-	-	3.2	-	-
50.8 (2")	1	19.9	12.73	12.7	63.5 ⁵	G ³ / ₈	-	9.5	38.1	-	25.4	7.5
	2	-	-	-	-	-	-	-	-	2.4	-	-
	3	-	-	-	-	-	-	-	-	-	-	-
63.5 (2½")	1	19.9	12.73	12.7	76.2 ⁵	G ³ / ₈	-	9.5	38.1	2.4	25.4	7.5
	2	-	-	-	-	-	-	-	-	-	-	-
	3	-	-	-	-	-	-	-	-	-	-	-
	7	-	-	-	-	-	-	-	-	-	-	-
82.6 (3¼")	1	32.6	19.08	15.8	95.2	G ¹ / ₂	-	15.9	44.5	-	31.8	10.0
	2	-	-	-	-	-	-	-	-	-	-	-
	3	-	-	-	-	-	-	-	-	-	-	-
	4	-	-	-	-	-	-	-	-	-	-	-
101.6 (4")	1	32.6	19.08	15.8	114.3	G ¹ / ₂	-	15.9	44.5	-	31.8	10.0
	2	-	-	-	-	-	-	-	-	-	-	-
	3	-	-	-	-	-	-	-	-	-	-	-
	4	-	-	-	-	-	-	-	-	-	-	-
127.0 (5")	1	32.6	19.08	15.8	139.7	G ¹ / ₂	-	15.9	44.5	-	31.8	13.0
	2	-	-	-	-	-	-	-	-	-	-	-
	3	-	-	-	-	-	-	-	-	-	-	-
	4	-	-	-	-	-	-	-	-	-	-	-
	5	-	-	-	-	-	-	-	-	-	-	-
152.4 (6")	1	38.9	25.43	19.1	165.1	G ³ / ₄	-	19.1	50.8	-	38.1	13.0
	2	-	-	-	-	-	-	-	-	-	-	-
	3	-	-	-	-	-	-	-	-	-	-	-
	4	-	-	-	-	-	-	-	-	-	-	-
	5	-	-	-	-	-	-	-	-	-	-	-
	6	-	-	-	-	-	-	-	-	-	-	-
	7	-	-	-	-	-	-	-	-	-	-	-

All dimensions are in millimetres unless otherwise stated.

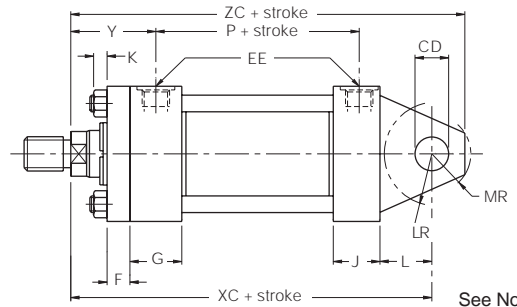
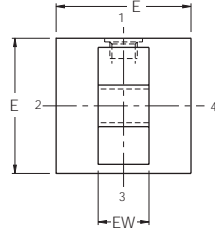
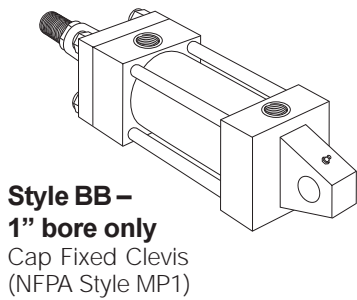

See Notes 3, 6

Notes

- 1 All cylinders are subject to maximum pressure ratings – see page 40.
- 2 Supplied complete with pivot pin. Dimension CD is the pivot pin diameter except for 25.4mm (1") bore.
- 3 On 25.4mm (1") bore size styles BB and BC a single eye clevis mounting lug 11.1mm thick is fitted. Dimension CD is the crosshole diameter – the pivot pin is not included.
- 4 Cylinders with long strokes being used in thrust (push) applications are limited by piston rod column strength. See piston selection chart on page 37.
- 5 The extra height 'H' of the port face applies to the head end of the bore and rod sizes shown in the table below and to the cap end of 38.1mm (1½") bore cylinders only.
- 6 R1 size BSPP ports to ISO 228/1 are supplied as standard on 3L cylinders. For smaller R2 size ports, see page 41.

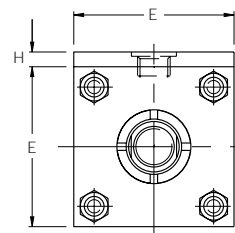

Dimensions BB & BC Continued

Bore Ø	Rod No.	L	LR	MR	Y	+ Stroke					
						LB	P	XC	XD	ZC	ZD
25.4 (1")	1	12.7	12.7	12.7	49	98.4	54	127.0	136.5	138.1	147.6
	49				127.0			136.5	138.1	147.6	
38.1 (1½")	1	19.1	14.3	15.9	49	101.6	58	136.5	146.1	149.2	158.8
	58				146.1			155.6	158.8	168.3	
50.8 (2")	1	19.1	14.3	15.9	49	101.6	58	136.5	146.1	149.2	158.8
	65				152.4			161.9	165.1	174.6	
	58				146.1			155.6	158.7	168.3	
63.5 (2½")	1	19.1	14.3	15.9	58	104.8	61	149.2	158.8	161.9	171.5
	71				161.9			171.5	174.6	184.2	
	65				155.6			165.1	168.2	177.8	
	49				139.7			149.2	152.4	161.9	
82.6 (3¼")	1	31.8	25.4	23.8	58	123.8	70	174.6	190.5	193.7	209.6
	74				190.5			206.4	209.6	225.4	
	65				181.0			196.9	200.0	215.9	
	71				187.3			203.2	206.4	222.3	
101.6 (4")	1	31.8	25.4	23.8	65	123.8	70	181.0	196.9	200.0	215.9
	81				196.9			212.7	215.9	231.8	
	71				187.3			203.2	206.4	222.3	
	74				190.5			206.4	209.6	225.4	
	58				174.6			190.5	193.7	209.6	
127.0 (5")	1	31.8	25.4	23.8	71	130.2	77	193.7	209.6	212.7	228.6
	81				203.2			219.1	222.3	238.1	
	74				196.9			212.7	215.9	231.8	
	81				203.2			219.1	222.3	238.2	
	81				203.2			219.1	222.3	238.2	
	58				181.0			196.9	200.6	215.9	
	65				187.3			203.2	206.4	222.3	
	74				212.7			231.8	238.2	257.4	
152.4 (6")	2	38.1	31.8	30.2	84	146.1	83	222.3	241.3	247.7	266.7
	78				215.9			235.0	241.3	260.4	
	84				222.3			241.3	247.7	266.7	
	84				222.3			241.3	247.7	266.7	
	84				222.3			241.3	247.7	266.7	
	84				222.3			241.3	247.7	266.7	
	68				206.4			225.4	231.8	250.8	

All dimensions are in millimetres unless otherwise stated.

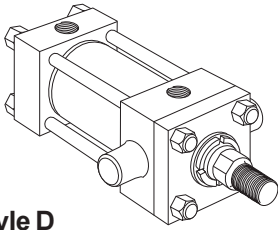

Style D
Head Trunnion
(NFA Style MT1)

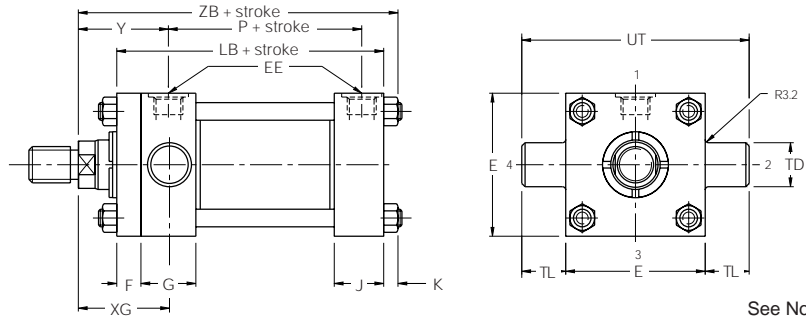

See Notes 2, 5, 6

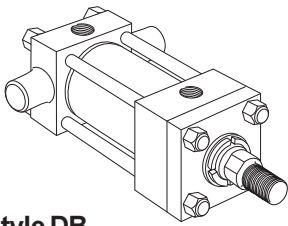

Style DB
Cap Trunnion
(NFA Style MT2)

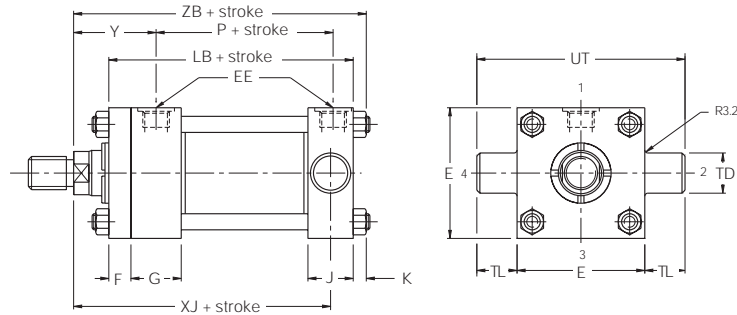

See Notes 2, 5, 6

Dimensions D, DB & DD See also Dimensions, page 3 & Mounting Information, pages 9 & 34

Bore Ø	Rod No.	BD	E	EE ⁶ (BSPP)	F	G	H ⁵	J	K	^{+0.00} TD _{-0.03}	TL	TM
25.4 (1")	1	-	38.1 ⁵	G ¹ / ₄	9.5	38.1	6.4	25.4	5.0	19.05	19.1	-
	2											
38.1 (1½")	1	31.7	50.8 ⁵	G ³ / ₈	9.5	38.1	-	25.4	6.4	25.40	25.4	63.5
	2						3.2					
50.8 (2")	1	38.1	63.5 ⁵	G ³ / ₈	9.5	38.1	-	25.4	7.5	25.40	25.4	76.2
	2						2.4					
	3						-					
63.5 (2½")	1	38.1	76.2 ⁵	G ³ / ₈	9.5	38.1	-	25.4	7.5	25.40	25.4	88.9
	2						2.4					
	3						-					
	7						-					
82.6 (3¼")	1	50.8	95.2	G ¹ / ₂	15.9	44.5	-	31.8	10.0	25.40	25.4	114.3
	2											
	3											
	4											
101.6 (4")	1	50.8	114.3	G ¹ / ₂	15.9	44.5	-	31.8	10.0	25.40	25.4	133.4
	2											
	3											
	4											
127.0 (5")	1	50.8	139.7	G ¹ / ₂	15.9	44.5	-	31.8	13.0	25.40	25.4	158.8
	2											
	3											
	4											
	5											
152.4 (6")	1	63.5	165.1	G ³ / ₄	19.1	50.8	-	38.1	13.0	34.92	34.9	193.7
	2											
	3											
	4											
	5											
	6											
	7											

All dimensions are in millimetres unless otherwise stated.

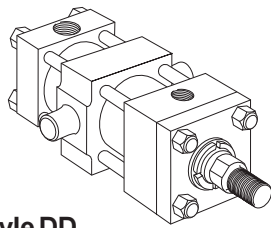

Style DD

Intermediate Fixed Trunnion
(NFPA Style MT4)

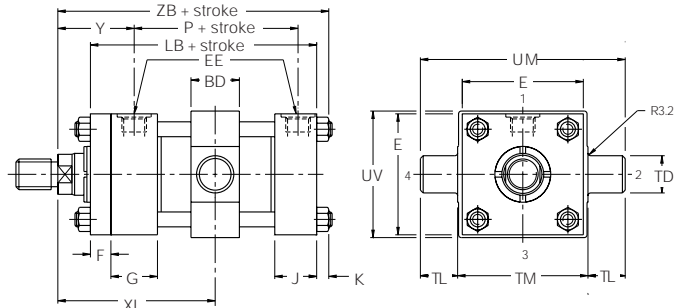

See Notes 1, 2, 3,
4, 5, 6

Notes

- 1 All cylinders are subject to maximum pressure ratings – see page 40.
- 2 Trunnions are nitro-carburised or chrome plated for improved corrosion resistance.
- 3 XI dimension to be specified by customer, note minimum dimension.
- 4 Not available in 25.4mm (1") bore size.
- 5 The extra height 'H' of the port face applies to the head end of the bore and rod sizes shown in the table below and to the cap end of 38.1mm (1½") bore cylinders only.
- 6 R1 size BSPP ports to ISO 228/1 are supplied as standard on 3L cylinders. For smaller R2 size ports, see page 41.

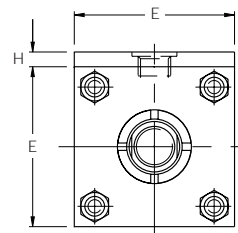

Dimensions D, DB & DD Continued

Bore Ø	Rod No.	UM	UT	UV	XG	Min. ³ XI	Y	Style DD Min. Stroke	+ Stroke			
									LB	P	XJ	ZB max.
25.4 (1")	1	-	76.2	-	44.5	-	49	-	98.4	54	101.6	119.3
	2				44.5	-	49				101.6	119.3
38.1 (1½")	1	114.3	101.6	63.5	44.5	80	49	3.2	101.6	58	104.7	123.8
	2				54.0	89	58				114.3	133.4
50.8 (2")	1	127.0	114.3	76.2	44.5	83	49	10.0	101.6	58	104.7	125.8
	2				60.3	99	65				120.7	141.7
	3				54.0	93	58				114.3	135.3
63.5 (2½")	1	139.7	127.0	88.9	54.0	93	58	6.4	104.8	61	117.4	138.4
	2				66.7	105	71				130.2	151.2
	3				60.3	99	65				123.8	144.9
	7				44.5	83	49				108.0	129.0
82.6 (3¼")	1	165.1	146.1	108.0	57.2	105	58	20.0	123.8	70	127.0	152.9
	2				73.0	121	74				142.9	168.8
	3				63.5	112	65				133.4	159.3
	4				69.8	118	71				139.7	165.6
101.6 (4")	1	184.2	165.1	127.0	63.5	112	65	20.0	123.8	70	133.4	159.3
	2				79.4	127	81				149.2	175.1
	3				69.8	118	71				139.7	165.6
	4				73.0	121	74				142.9	168.8
	7				57.2	105	58				127.0	152.9
127.0 (5")	1	209.6	190.5	152.4	69.8	118	71	13.0	130.2	77	146.1	174.9
	2				79.4	127	81				155.6	184.0
	3				73.0	121	74				149.2	178.1
	4				79.4	127	81				155.6	184.5
	5				79.4	127	81				155.6	184.5
	7				57.2	105	58				133.4	162.2
	8				63.5	112	65				139.7	168.6
	7				66.7	124	68				149.2	181.3
152.4 (6")	1	263.6	235.0	177.8	73.0	131	74	26.0	146.1	83	155.6	187.6
	2				82.6	140	84				165.1	197.2
	3				76.2	134	78				158.8	191.8
	4				82.6	140	84				165.1	197.2
	5				82.6	140	84				165.1	197.2
	6				82.6	140	84				165.1	197.2
	7				66.7	124	68				149.2	181.3

All dimensions are in millimetres unless otherwise stated.

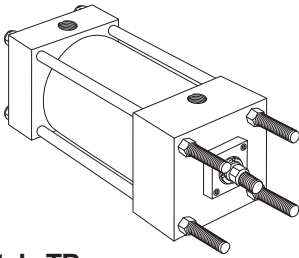

Style TB

Tie Rods Extended Head End
(NFPA Style MX3)

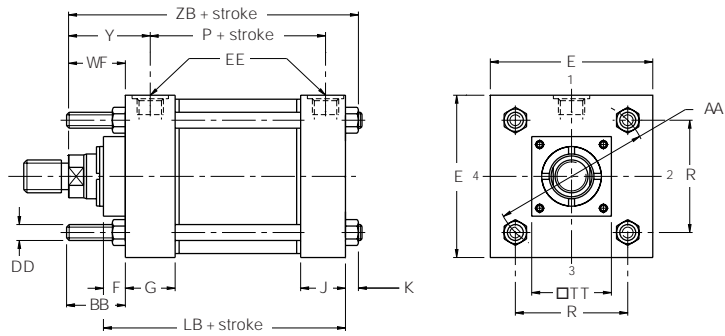

See Notes 1, 2, 3

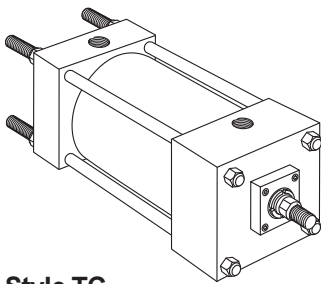

Style TC

Tie Rods Extended Cap End
(NFPA Style MX2)

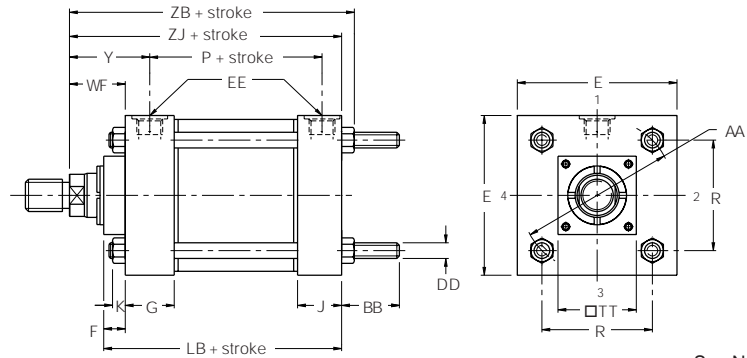

See Notes 1, 2, 3

Dimensions TB, TC & TD See also Dimensions, page 46 & Mounting Information, pages 9 & 34

Bore Ø	Rod No.	AA	BB	DD (UNF)	E	EE ³ (BSPP)	F	G	J	K
203.2 (8")	1	231.1	58.7	5/8-18	215.9	G ³ / ₄	19.1	50.8	38.1	16
	2									
	3									
	4									
	5									
	6									
	7									
	8									
	0									

All dimensions are in millimetres unless otherwise stated.

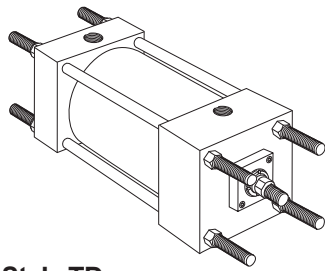

Style TD

Tie Rods Extended Both Ends
(NFFA Style MX1)

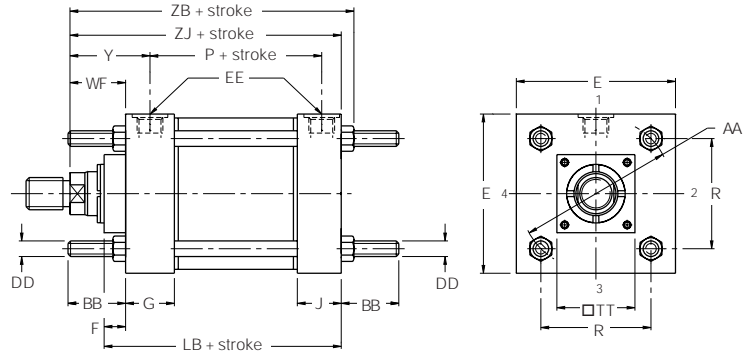

See Notes 1, 2, 3

Notes

- 1 All cylinders are subject to maximum pressure ratings – see page 40.
- 2 For Styles TB and TC an additional set of mounting nuts are supplied. For Style TD, two additional sets of mounting nuts are supplied.
- 3 R1 size BSPP ports to ISO 228/1 are supplied as standard on 3L cylinders. For smaller R2 size ports, see page 41.

Dimensions TB, TC & TD Continued

Bore Ø	Rod No.	R	TT	WF	Y	+ Stroke			
						LB	P	ZB max.	ZJ
203.2 (8")	1	163.6	101.6	50.8	78	149.2	86	197.0	181.0
	2		177.8	57.2	84			203.3	187.3
	3		101.6	57.2	84			203.3	187.3
	4		139.7	57.2	84			203.3	187.3
	5		139.7	57.2	84			203.3	187.3
	6		139.7	57.2	84			203.3	187.3
	7		101.6	41.3	68			187.4	171.5
	8		101.6	47.6	74			193.8	177.8
	0		177.8	57.2	84			203.3	187.3

All dimensions are in millimetres unless otherwise stated.

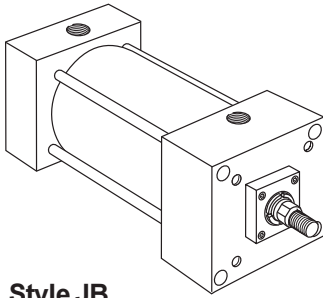

Style JB

Head Square
(NFPA Style ME3)

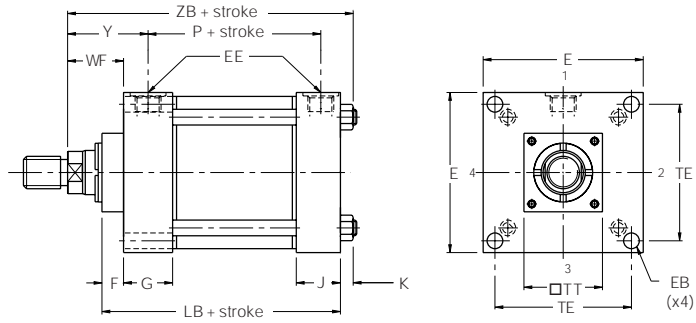

See Notes 1, 3

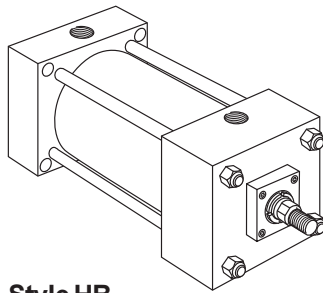

Style HB

Cap Square
(NFPA Style ME4)

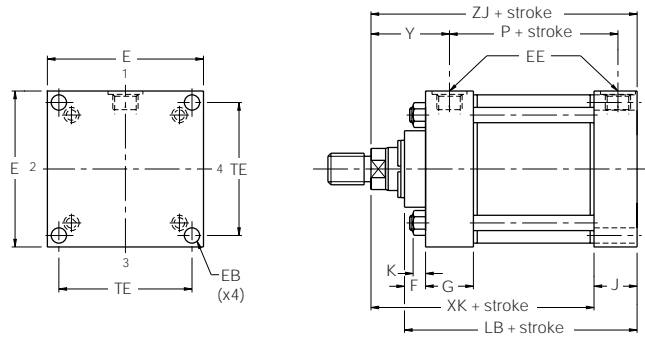

See Notes 1, 3

Dimensions JB, HB & BB See also Dimensions, page 46 & Mounting Information, pages 9 & 34

Bore Ø	Rod No.	CB	$^{+0.00}_{-0.05}$ CD	CW	E	EB	EE ³ (BSPP)	F	G	J	K	L	LR
203.2 (8")	1	39.7	25.43	19.1	215.9	18	G ³ / ₄	19.1	50.8	38.1	16	38.1	31.8
	2												
	3												
	4												
	5												
	6												
	7												
	8												
	0												

All dimensions are in millimetres unless otherwise stated.

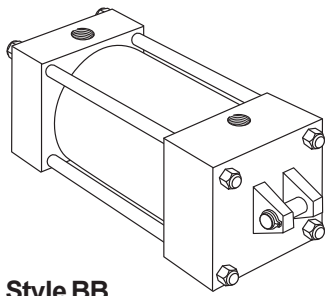

Style BB
Cap Fixed Clevis
(NFPA Style MP1)

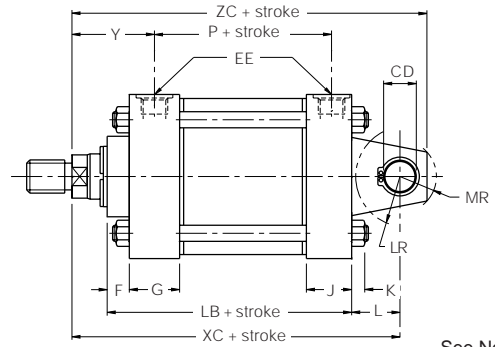
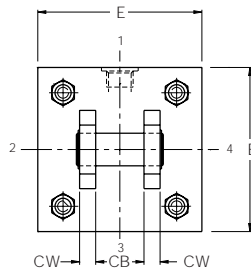

See Notes 1, 2, 3

Notes

- 1 All cylinders are subject to maximum pressure ratings – see page 40.
- 2 Supplied complete with pivot pin.
- 3 R1 size BSPP ports to ISO 228/1 are supplied as standard on 3L cylinders. For smaller R2 size ports, see page 41.

Dimensions JB, HB & BB Continued

Bore Ø	Rod No.	MR	TE	TT	WF	Y	+ Stroke						
							LB	P	XC	XK	ZB max.	ZC	ZJ
203.2 (8")	1	30.2	192.3	101.6	50.8	78	149.2	86.0	219.1	142.9	197.0	244.5	181.0
	2			177.8	57.2	84			225.4	149.2	203.3	250.8	187.3
	3			101.6	57.2	84			225.4	149.2	203.3	250.8	187.3
	4			139.7	57.2	84			225.4	149.2	203.3	250.8	187.3
	5			139.7	57.2	84			225.4	149.2	203.3	250.8	187.3
	6			139.7	57.2	84			225.4	149.2	203.3	250.8	187.3
	7			101.6	41.3	68			209.5	133.4	187.4	235.0	171.5
	8			101.6	47.6	74			215.9	139.7	193.8	241.3	177.8
	0			177.8	57.2	84			225.4	149.2	203.3	250.8	187.3

All dimensions are in millimetres unless otherwise stated.

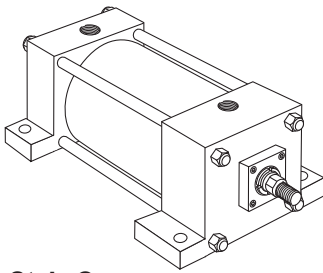

Style C
 Side Lug Mounting
 (NFPA Style MS2)

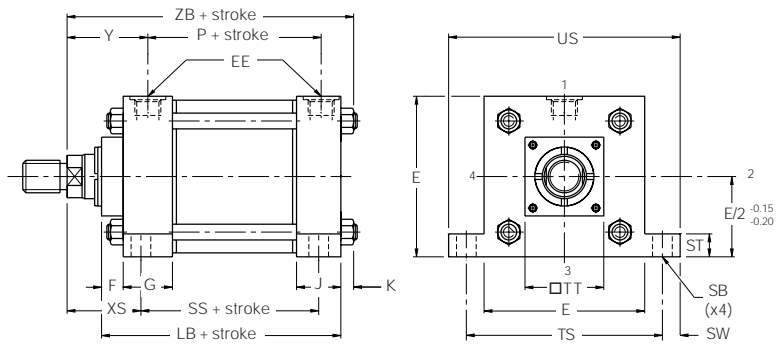

See Notes 1, 2, 4, 6

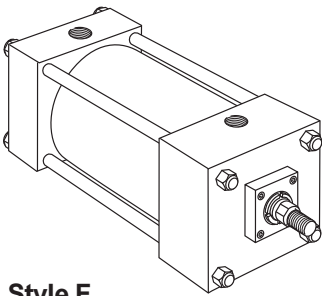

Style F
 Side Tapped Mounting
 (NFPA Style MS4)

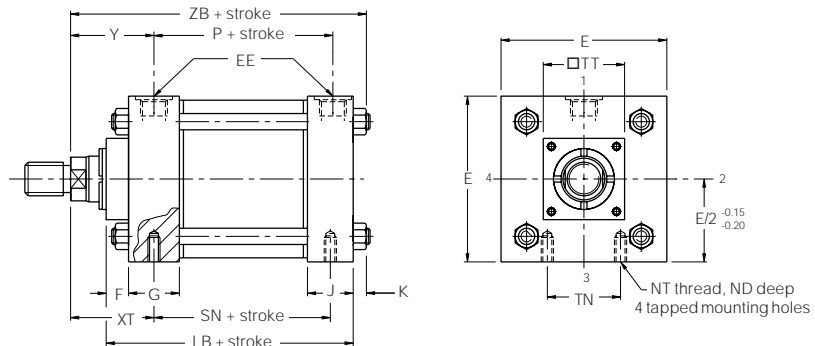

See Notes 1, 5, 6

Dimensions C, F & G See also Dimensions, page 46 & Mounting Information, pages 9 & 34

Bore Ø	Rod No.	E	EB	EE ⁶ (BSPP)	EL	EO	ES	ET	F	G	J	K	ND	NT ⁵	R	SB	ST
203.2 (8")	1																
	2																
	3																
	4																
	5	215.9	18	G ³ / ₄	28.6	15.9	57.2	50.8	19.1	50.8	38.1	16	28.6	M20	163.6	22	25.4
	6																
	7																
	8																
	9																
	0																

All dimensions are in millimetres unless otherwise stated.

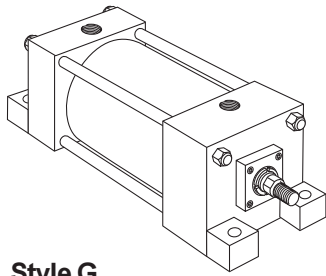

Style G
 Side End Lug
 (NFFA Style MS7)

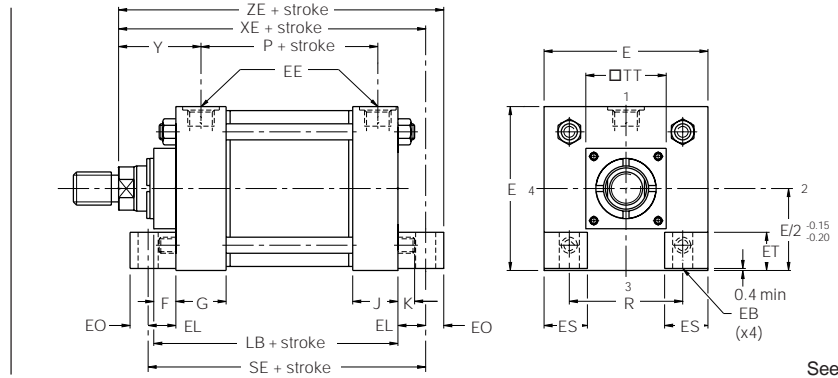

See Notes 1, 3, 6

Notes

- 1 All cylinders are subject to maximum pressure ratings – see page 40.
- 2 Upper surfaces of lugs are machined for socket head screws.
- 3 For mounting style G, rod diameters greater than 63.5mm (2 1/2"), i.e. rod numbers 2, 4, 5, 6 and 0, are not available.
- 4 Style C cylinders can be supplied with the cylinder ports arranged for mounting and sealing to a manifold surface – see page 35.
- 5 Tapped mounting holes are metric (coarse pitch series).
- 6 R1 size BSPP ports to ISO 228/1 are supplied as standard on 3L cylinders. For smaller R2 size ports, see page 41.

Dimensions C, F & G Continued

Bore Ø	Rod No.	SW	TN	TS	TT	US	XS	XT	Y	+ Stroke							
										LB	P	SE	SN	SS	XE	ZB max.	ZE
203.2 (8")	1				101.6		68.3	81.0	78						209.6	197.0	225.4
	2				177.8		74.6	87.3	84						-	203.3	-
	3				101.6		74.6	87.3	84						215.9	203.3	231.8
	4				139.7		74.6	87.3	84						-	203.3	-
	5	17.5	114.3	250.8	139.7	285.8	74.6	87.3	84	149.2	86	187.3	82.6	95.3	-	203.3	-
	6				139.7		74.6	87.3	84						-	203.3	-
	7				101.6		58.7	71.4	68						200.0	187.4	215.9
	8				101.6		65.1	77.8	74						206.4	193.8	222.3
	0				177.8		74.6	87.3	84						-	203.3	-

All dimensions are in millimetres unless otherwise stated.

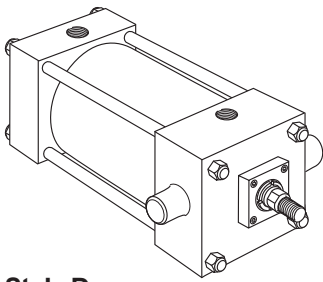

Style D
 Head Trunnion
 (NFPA Style MT1)

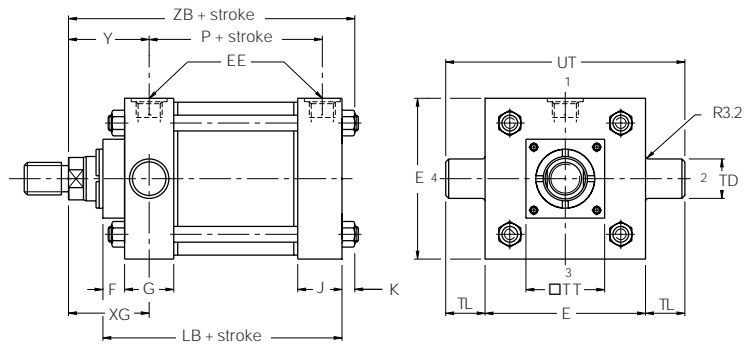

See Notes 1, 2, 4

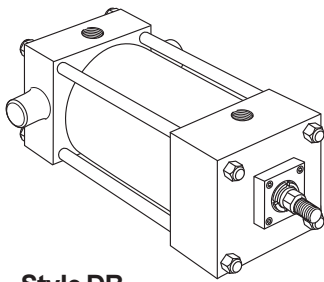

Style DB
 Cap Trunnion
 (NFPA Style MT2)

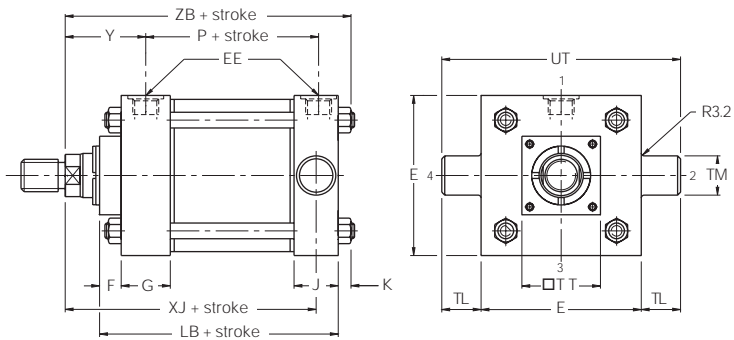

See Notes 1, 2, 4

Dimensions D, DB, & DD See also Dimensions, page 46 & Mounting Information, pages 9 & 34

Bore Ø	Rod No.	BD	E	EE ⁴ (BSPP)	F	G	J	K	^{+0.00} TD _{-0.03}	TL	TM	TT
203.2 (8")	1	63.5	215.9	G ³ / ₄	19.1	50.8	38.1	16	34.93	34.9	247.7	101.6
	2											177.8
	3											101.6
	4											139.7
	5											139.7
	6											139.7
	7											101.6
	8											101.6
	0											177.8

All dimensions are in millimetres unless otherwise stated.

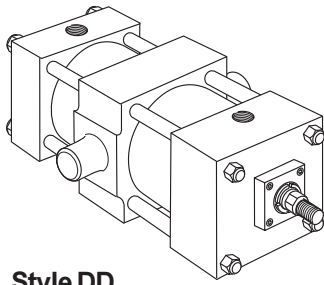

Style DD
 Intermediate Fixed Trunnion
 (NFFA Style MT4)

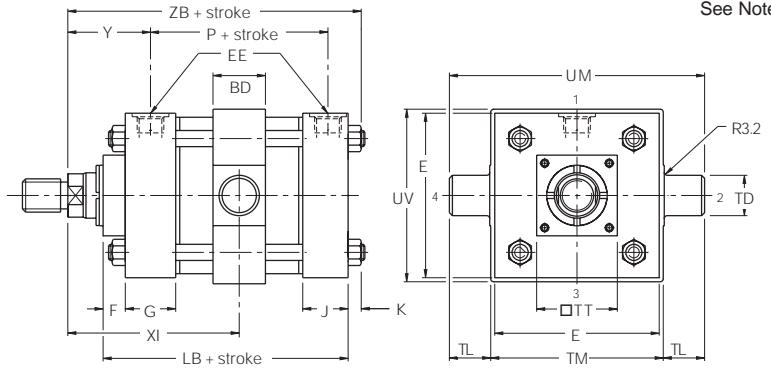

See Notes 1, 2, 3, 4

Notes

- 1 All cylinders are subject to maximum pressure ratings – see page 40.
- 2 Trunnions are nitro-carburised or chrome plated for improved corrosion resistance.
- 3 XI dimension to be specified by customer, note minimum dimension.
- 4 R1 size BSPP ports to ISO 228/1 are supplied as standard on 3L cylinders. For smaller R2 size ports, see page 41.

Dimensions D, DB, & DD Continued

Bore Ø	Rod No.	UM	UT	UV	XG	Min. XI ³	Y	Style DD min.stroke	+ Stroke			
									LB	P	XJ	ZB max.
203.2 (8")	1	317.5	285.7	241.3	76.2	133.4	78	22.2	149.2	86	161.9	197.0
	2				82.6	139.7	84				168.3	203.3
	3				82.6	139.7	84				168.3	203.3
	4				82.6	139.7	84				168.3	203.3
	5				82.6	139.7	84				168.3	203.3
	6				82.6	139.7	84				168.3	203.3
	7				66.7	123.8	68				152.4	187.4
	8				73.0	130.2	74				158.8	193.8
	0				82.6	139.7	84				168.3	203.3

All dimensions are in millimetres unless otherwise stated.

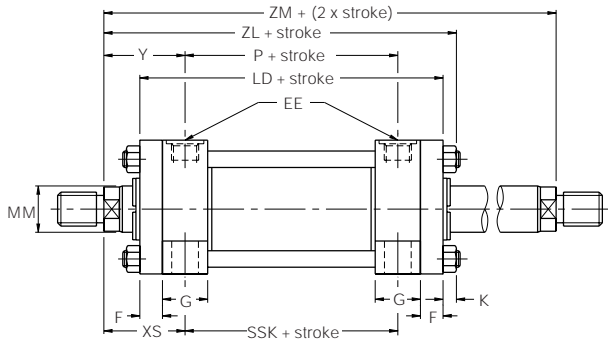

Double Rod Cylinders Available with Styles TB, TD,
25.4 to 152.4mm Bores J, JB, C, F, G, D and DD

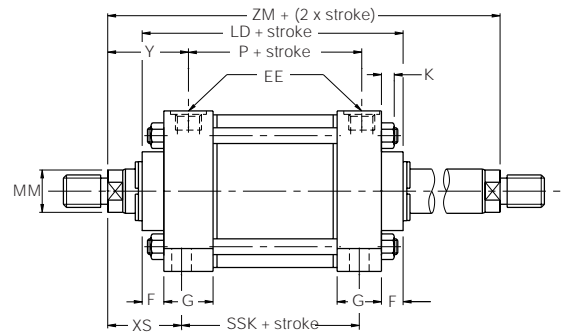

Double Rod Cylinders Available with Styles TB,
203.2mm Bores TD, JB, C, F, G, D, and DD

Mounting Styles and Codes

Double rod cylinders are denoted by a 'K' in the model code, shown on page 47.

Dimensions

To obtain dimensional information for double rod cylinders, first select the desired mounting style by referring to the corresponding single rod models shown on the preceding pages. Dimensions for the appropriate single rod model should be supplemented by those from the table opposite to provide a full set of dimensions.

Rod Strength

Double rod cylinders employ two separate piston rods, with one screwed into the end of the other within the piston rod assembly. As a result, one piston rod is stronger than the other. The stronger rod is identified by the letter 'K' stamped on its end, and its pressure limitations with a 4:1 design factor are identical to those shown in the table on page 40 for the equivalent single rod assembly. The weaker rod should always be used for the lighter duty. Pressure limitations for the weaker rod in pull applications at a 4:1 design factor are also identical to those on page 40.

Combination Rods

Double rod cylinders with stronger and weaker rods of differing rod sizes are also available. Please contact the factory for details.

Cushioning

Double rod cylinders can be supplied with cushions at either or both ends. Cushioning requirements should be specified by inserting a 'C' in the ordering code – see page 47. Double rod cylinders that require cushioning are supplied with floating cushion sleeves as standard.

Style 9 Rod Ends

If a stroke of less than 25mm on bore sizes up to 82.6mm (3 1/4"), or a stroke of less than 100mm on bore sizes of 101.6mm (4") and over, is required, where Style 9 rod ends are required at both ends, please consult the factory.

Bore Ø	Rod No.	MM Rod Diameter	Add Stroke			Add 2 x Stroke	
			LD	ZL	SSK	ZM	
25.4 (1")	1	12.7 (1/2")	120.7	139.7	85.7	152.4	
	2	15.9 (5/8")					
38.1 (1 1/2")	1	15.9 (5/8")	123.8	146.1	85.7	155.6	
	2	25.4 (1")					155.6
50.8 (2")	1	15.9 (5/8")	123.8	147.6	85.7	155.6	
	2	34.9 (1 3/8")					163.5
	3	25.4 (1")					157.1
63.5 (2 1/2")	1	25.4 (1")	127.0	160.3	88.9	177.8	
	2	44.5 (1 3/4")					173.0
	3	34.9 (1 3/8")					166.7
	7	15.9 (5/8")					150.8
82.6 (3 1/4")	1	25.4 (1")	152.4	181.0	95.3	190.6	
	2	50.8 (2")					196.9
	3	34.9 (1 3/8")					187.3
	4	44.5 (1 3/4")					193.6
101.6 (4")	1	34.9 (1 3/8")	152.4	187.3	95.3	203.2	
	2	63.5 (2 1/2")					203.2
	3	44.5 (1 3/4")					193.6
	4	50.8 (2")					196.9
	7	25.4 (1")					181.0
127.0 (5")	1	44.5 (1 3/4")	158.8	201.6	92.1	222.3	
	2	88.9 (3 1/2")					211.1
	3	50.8 (2")					204.7
	4	63.5 (2 1/2")					211.1
	5	76.2 (3")					211.1
	7	25.4 (1")					188.9
	8	34.9 (1 3/8")					195.2
	8	34.9 (1 3/8")					195.2
152.4 (6")	1	44.5 (1 3/4")	178.0	217.4	104.8	235.2	
	2	101.6 (4")					227.0
	3	50.8 (2")					220.7
	4	63.5 (2 1/2")					227.0
	5	76.2 (3")					227.0
	6	88.9 (3 1/2")					227.0
	7	34.9 (1 3/8")					211.1
203.2 (8")	1	50.8 (2")	181.0	-	108.0	244.5	
	2	139.7 (5 1/2")					257.2
	3	63.5 (2 1/2")					257.2
	4	76.2 (3")					257.2
	5	88.9 (3 1/2")					257.2
	6	101.6 (4")					257.2
	7	34.9 (1 3/8")					225.4
	8	44.5 (1 3/4")					238.3
	0	127.0 (5")					257.2

All dimensions are in millimetres unless otherwise stated.

Accessory Selection

Accessories for the rod end of a cylinder are selected by reference to the rod end thread, shown on pages 3 and 46, while the same accessories, when used at the cap end, are selected by cylinder bore size. See tables of part numbers below and on the following pages.

Rod and Cap End Accessories

Accessories for the 3L cylinder comprise:

- Rod End** – rod clevis, eye bracket and pivot pin
 – plain rod eye, clevis bracket and pivot pin

- Cap End** – eye bracket for style BB mounting

Load Capacity

The various accessories on these pages have been load rated for your convenience. The load capacity in kN is the recommended maximum load for that accessory based on a 4:1 factor of safety in tension. (The pivot pin is rated in shear). Before specifying, compare the actual load or the pull force at maximum operating pressure of the cylinder with the load capacity of the accessory you plan to use. If the load or pull force of the cylinder exceeds the load capacity of the accessory, please consult the factory.

Rod Clevis, Eye Bracket and Pivot Pin

Thread KK	Rod Clevis	Eye Bracket	Pivot Pin	Nominal Force kN	Mass kg
M8x1.25	51221G	74077	-	7.7	0.4
M10x1.5	50940G	69195	68368	18.3	0.7
M12x1.5	50941G	69195	68368	18.3	0.7
M20x1.5	50942G	69196	68369	46.8	2.3
M22x1.5	50943G	85361 ¹	68370	83.8	5.2
M26x1.5	50944G	85361 ¹	68370	91.0	5.1
M33x2	50945G	69198	68371	94.5	9.9
M39x2	50946G	85362 ¹	68372	203.3	19.5
M45x2	50947G	85363 ¹	68373	312.1	28.6
M48x2	50948G	85363 ¹	68373	312.1	28.5
M58x2	50949G	85364 ¹	68374	420.0	48.4
M64x2	50950G	85365 ¹	68375	420.0	63.4
M68x2	50951G	85365 ¹	68375	543.6	63.1
M76x2	50952G	73538	73545	256.0	104.8
M90x2	50953G	73539	73547	334.4	157.8
M100x2	50954G	73539	73547	334.4	156.6
M110x2	-	-	-	-	-

Plain Rod Eye, Clevis Bracket and Pivot Pin

Thread KK	Plain Rod Eye	Clevis Bracket	Pivot Pin	Nominal Force kN	Mass kg
M8x1.25	74075G	74076	74078	15.0	0.5
M10x1.5	69089G	69205	68368	22.3	1.3
M12x1.5	69090G	69205	68368	25.4	1.3
M20x1.5	69091G	69206	68369	54.0	3.2
M22x1.5	69092G	69207	68370	58.0	6.6
M26x1.5	69093G	69207	68370	85.6	6.6
M33x2	69094G	69208	68371	149.4	12.7
M39x2	69095G	69209	68372	151.6	23.4
M45x2	69096G	69210	69215	147.2	41.1
M48x2	69097G	69210	69215	147.2	41.5
M58x2	69098G	69211	68374	155.6	51.2
M64x2	69099G	69212	68375	150.7	65.2
M68x2	69100G	69213	69216	164.6	69.5
M76x2	73536G	73542	73545	372.3	126.7
M90x2	73437G	73542	73545	372.3	124.0
M100x2	73438G	73543	82181	457.5	180.7
M110x2	73439G	73544	73547	483.4	173.5

Cap End Eye Bracket for Styles BB and BC Cylinders

Bore Ø	Eye Bracket Part No.	Nominal Force kN	Mass kg
25.4 (1")	74076 ²	16.0	0.4
38.1 (1½")	69195	18.3	0.4
50.8 (2")	69195	18.3	0.4
63.5 (2½")	69195	18.3	0.4
82.6 (3¼")	69196	46.8	1.5
101.6 (4")	69196	46.8	1.5
127.0 (5")	69196	46.8	1.5
152.4 (6")	85361 ¹	91.0	3.4
203.2 (8")	85361 ¹	91.0	3.4

¹ Cylinder accessory dimensions conform to NFPA recommended standard, NFPA/T3.6.8.R1 – 1984

² Mounting plate for 25.4mm (1") bore single tang BB and BC mounting styles is Clevis Bracket 74076, shown on page 33

All dimensions are in millimetres unless otherwise stated.

Rod Clevis, Eye Bracket and Pivot Pin

Rod Clevis Dimensions

Part No.	A	CB	+0.10 CD +0.05	CE	CW	ER	KK	Nominal Force kN	Mass kg
51221G ¹	20.6	8.8	7.90	57.2	5.2	7.5	M8x1.25	11.6	0.1
50940G	19.1	19.8	12.70	38.1	12.7	12.7	M10x1.5	18.9	0.2
50941G	19.1	19.8	12.70	38.1	12.7	12.7	M12x1.5	21.9	0.2
50942G	28.6	32.6	19.05	54.0	15.9	19.1	M20x1.5	49.9	0.6
50943G	41.3	38.9	25.40	74.6	19.1	25.4	M22x1.5	83.8	1.3
50944G	41.3	38.9	25.40	74.6	19.1	25.4	M26x1.5	96.7	1.3
50945G	50.8	51.6	34.93	95.3	25.4	34.9	M33x2	149.4	3.1
50946G	57.2	64.7	44.45	114.3	31.8	44.5	M39x2	203.3	6.0
50947G	76.2	64.7	50.80	139.7	31.8	50.8	M45x2	317.9	8.4
50948G	76.2	64.7	50.80	139.7	31.8	50.8	M48x2	341.6	8.3
50949G	88.9	77.4	63.50	165.1	38.1	63.5	M58x2	480.2	15.1
50950G	88.9	77.4	76.20	171.5	38.1	69.9	M64x2	535.1	19.0
50951G	88.9	77.4	76.20	171.5	38.1	69.9	M68x2	589.9	18.7
50952G	88.9	102.8	88.90	196.9	50.8	88.9	M76x2	1048.8	34.1
50953G	101.6	116.0	101.6	223.8	57.2	101.6	M90x2	1292.2	49.8
50954G	101.6	116.0	101.6	223.8	57.2	101.6	M100x2	1480.0	48.6

Rod Clevis (Female Clevis)

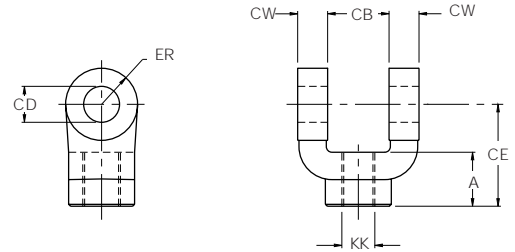

Eye Bracket Dimensions

Part No.	CB	+0.10 CD +0.05	DD	E	F	FL	LR	M	MR	R	Nominal Force kN	Mass kg
74077	7.9	7.9	6.8	57.2	9.5	25.4	15.9	9.5	12.7	44.5	7.6	0.3
69195	19.1	12.70	10.3	63.5	9.5	28.6	19.1	12.7	14.3	41.4	18.3	0.4
69196	31.8	19.05	13.5	88.9	15.9	47.6	31.8	19.1	22.2	64.8	46.8	1.5
85361 ²	38.1	25.40	16.7	114.3	22.2	60.3	38.1	25.4	31.8	82.6	91.0	3.4
69198	50.8	34.93	16.7	127.0	22.2	76.2	54.0	34.9	41.3	97.0	94.5	5.6
85362 ²	63.5	44.45	23.0	165.1	28.6	85.7	57.2	44.5	54.0	125.7	220.6	11.1
85363 ²	63.5	50.80	27.0	190.5	38.1	101.6	63.5	50.8	61.9	145.5	312.1	17.0
85364 ²	76.2	63.50	30.2	215.9	44.5	120.6	76.2	63.5	76.2	167.1	420.0	27.4
85365 ²	76.2	76.20	33.3	241.3	50.8	133.3	82.6	69.9	82.6	190.5	543.6	35.8
73538	101.6	88.90	46.0	320.7	42.9	144.5	101.6	88.9	95.3	244.3	256.0	55.6
73539	114.3	101.6	52.4	377.8	49.2	163.5	114.3	101.6	108.0	290.8	334.4	84.3

Eye Bracket

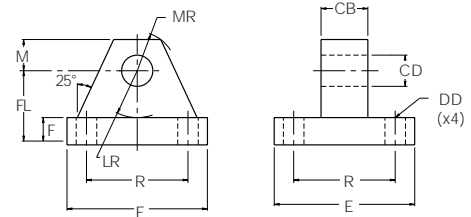

Pivot Pin for Clevis Bracket & Eye Bracket

Part No.	+0.00 CD -0.05	+0.0 CL -0.5	G	Nominal Force kN	Mass kg
74078	11.1	32.7	40	29.4	0.03
68368	12.73	46.3	56	38.4	0.1
68369	19.08	65.4	75	86.1	0.2
68370	25.43	77.9	88	152.9	0.5
68371	34.95	103.4	115	289.8	1.2
68372	44.48	128.8	143	469.1	2.4
68373	50.83	129.7	145	612.7	3.2
69215	50.83	141.4	158	612.7	3.5
68374	63.53	155.1	171	957.4	5.9
68375	76.23	154.7	173	1378.7	8.6
69216	76.23	167.7	185	1378.7	9.2
73545	88.93	205.7	225	1876.8	15.2
82181	101.63	215.5	235	2522.9	22.4
73547	101.63	231.7	251	2522.9	23.5

Pivot Pin for Clevis Bracket & Eye Bracket

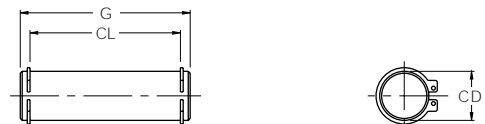

¹ Includes pivot pin

² Cylinder accessory dimensions conform to NFPA recommended standard, NFPA/T3.6.8.R1 - 1984

All dimensions are in millimetres unless otherwise stated.

Plain Rod Eye and Clevis Bracket

Plain Rod Eye Dimensions

Part No.	A min.	CA	CB	CD	ER	KK	Nominal Force kN	Mass kg
74075G	19.1	38.1	11.1	11.1	15.2	M8x1.25	14.7	0.1
69089G	19.1	38.1	19.1	12.70	18.3	M10x1.5	22.3	0.2
69090G	19.1	38.1	19.1	12.70	18.3	M12x1.5	25.4	0.2
69091G	28.6	52.4	31.8	19.05	27.0	M20x1.5	54.0	0.5
69092G	28.6	60.3	38.1	25.40	36.5	M22x1.5	58.0	1.1
69093G	41.3	71.4	38.1	25.40	36.5	M26x1.5	96.8	1.1
69094G	50.8	87.3	50.8	34.93	50.0	M33x2	149.4	2.6
69095G	57.2	101.6	63.5	44.45	63.5	M39x2	200.6	5.1
69096G	57.2	111.1	63.5	50.80	72.2	M45x2	238.6	6.4
69097G	76.2	127.0	63.5	50.80	72.2	M48x2	334.4	6.8
69098G	88.9	147.6	76.2	63.50	90.5	M58x2	440.1	12.1
69099G	88.9	155.6	76.2	76.20	108.0	M64x2	490.5	16.0
69100G	92.1	165.1	88.9	76.20	108.0	M68x2	549.8	19.6
73536G	101.6	193.7	101.6	88.90	126.2	M76x2	719.3	31.1
73437G	127.0	193.7	101.6	88.90	126.2	M90x2	969.0	28.4
73438G	139.7	231.8	114.3	101.6	144.5	M100x2	1220.9	42.5
73439G	139.7	231.8	127.0	101.6	144.5	M110x2	1375.6	48.4

Plain Rod Eye

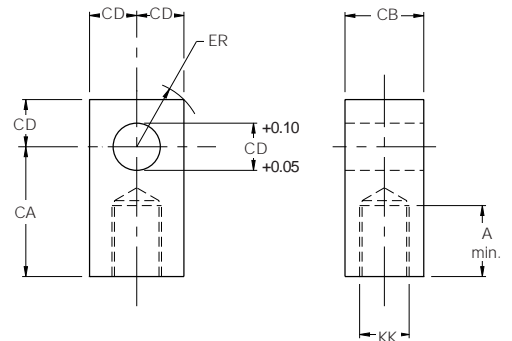

Clevis Bracket Dimensions

Part No.	CB	+0.10 CD +0.05	CW	DD	E	F	FL	LR	M	MR	R	Nominal Force kN	Mass kg
74076	12.0	11.1	9.5	6.8	57.2	9.5	25.4	15.9	9.5	12.7	44.5	16.0	0.4
69205	19.8	12.70	12.7	10.3	88.9	12.7	38.1	19.1	12.7	15.9	64.8	32.6	1.0
69206	32.6	19.05	15.9	13.5	127.0	15.9	47.6	30.2	19.1	23.0	97.0	62.4	2.5
69207	38.9	25.40	19.1	16.7	165.1	19.1	57.2	38.1	25.4	31.8	125.7	85.6	5.0
69208	51.6	34.93	25.4	16.7	190.5	22.2	76.2	50.8	34.9	42.1	145.5	164.6	8.8
69209	64.7	44.45	31.8	23.0	241.3	22.2	92.1	69.9	44.5	56.4	190.5	151.6	15.9
69210	64.7	50.80	38.1	27.0	323.9	25.4	108.0	81.0	57.2	70.6	238.8	147.2	31.2
69211	77.4	63.50	38.1	30.2	323.9	25.4	114.3	88.9	63.5	79.4	238.8	155.6	33.2
69212	77.4	76.20	38.1	33.3	323.9	25.4	152.4	108.0	76.2	91.3	238.8	150.7	40.7
69213	90.1	76.20	38.1	33.3	323.9	25.4	152.4	108.0	76.2	91.3	238.8	164.6	40.7
73542	102.8	88.90	50.8	46.0	393.7	42.9	169.9	127.0	88.9	104.8	304.8	372.3	80.4
73543	116.0	101.6	50.8	52.4	444.5	49.2	195.3	146.1	101.6	123.8	349.3	457.5	115.8
73544	128.2	101.6	50.8	52.4	444.5	49.2	195.3	146.1	101.6	123.8	349.3	483.4	101.6

Clevis Bracket

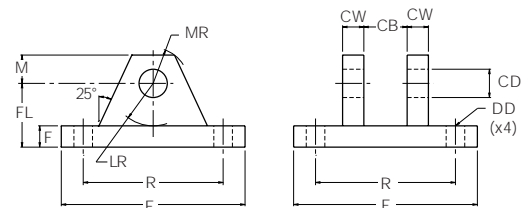

All dimensions are in millimetres unless otherwise stated.

Mounting Styles

General guidance for the selection of mounting styles is given on page 9. The notes which follow provide information for use in specific applications and should be read in conjunction with the information given on page 9.

Extended Tie Rods

The standard tie rod extension for cylinders with mounting styles TB, TC and TD is shown as BB in dimension tables. Longer or shorter extensions can be supplied.

Cylinders with extended tie rod mountings TB and TC are supplied with an additional set of mounting nuts of the appropriate grade for securing the cylinder to the machine member. For style TD, tie rods extended both ends, two additional sets of mounting nuts are supplied.

Cylinders may be ordered with extended tie rods in addition to another mounting style. The extended tie rods may then be used for mounting other systems or machine components.

Flange Mounted Cylinders

The diameter of the rod gland extension (B) at the head end can be used as a pilot to locate the cylinder in relation to the machine. After alignment has been obtained, the flange may be drilled for pins or dowels to prevent shifting.

Pivot Mountings

Pivot pins are supplied with Style BB cap fixed clevis mounted cylinders and Style BC cap detachable clevis mounted cylinders, with the exception of 1" bore sizes.

Trunnion Mounted Cylinders

Trunnions require lubricated pillow blocks with minimum bearing clearances. Blocks should be aligned and mounted to eliminate bending moments on the trunnion pins. Self-aligning mounts must not be used to support the trunnions as bending forces can be set up.

An intermediate fixed trunnion mounting can be positioned to balance the weight of the cylinder, or it can be located at any point between the head or cap to suit the application. The position of the trunnion is fixed during manufacture and its location must be specified at the time of order.

Foot Mounted Cylinders

Foot mounted cylinders should not be pinned or keyed at both ends. Changes in temperature and pressure under normal operating conditions cause the cylinder to increase (or decrease) from its installed length and it therefore must be free to expand and contract. It must not be pinned or keyed at both ends as advantages of cylinder elasticity in absorbing high shock loads would be lost.

Foot Mountings and Thrust Keys

The turning moment which results from the application of force by a foot mounted cylinder must be resisted by secure mounting and effective guidance of the load. A thrust key modification is recommended to provide positive cylinder location.

Thrust key mountings eliminate the need for fitted bolts or external keys on Styles C, F and G side mounted cylinders. The gland retainer plate is extended below the nominal mounting surface to fit into a keyway milled into the mounting surface of the machine member. See 'Mounting Modifications' in the order code, page 47.

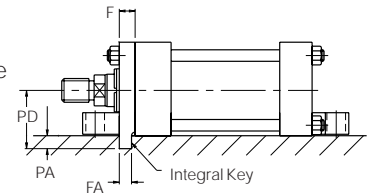

Bore Ø	F Nom.	+0.0 FA -0.075	+0.0 PA -0.2	PD
25.4 (1") ¹	9.5	8	4.9	23.8
38.1 (1 1/2")	9.5	8	4.9	30.2
50.8 (2")	9.5	8	4.9	36.5
63.5 (2 1/2")	9.5	8	4.9	42.9
82.6 (3 1/4")	15.9	14	8.1	55.6
101.6 (4")	15.9	14	8.1	65.1
127.0 (5")	15.9	14	8.1	77.8
152.4 (6")	19.1	18	9.5	92.1

¹ G mounting is not available with a thrust key on 25.4mm (1") bore.

Tie Rod Supports

To increase the resistance to buckling of long stroke cylinders, tie rod supports may be fitted.

These move the tie rods radially outwards and allow longer than normal strokes to be used without the need for an additional mounting.

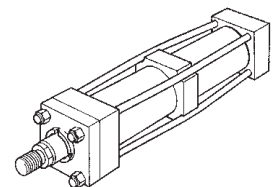

Bore Ø	Stroke (metres)												No. of Supports Req'd.
	0.9	1.2	1.5	1.8	2.1	2.4	2.7	3.0	3.3	3.6	3.9	4.2	
38.1	-	-	1	1	1	2	2	2	3	3	3	4	
50.8	-	-	-	1	1	1	1	2	2	2	2	3	
63.5	-	-	-	-	-	1	1	1	1	1	2	2	
82.6	-	-	-	-	-	-	-	1	1	1	1	1	
101.6	-	-	-	-	-	-	-	-	-	1	1	1	

Bore sizes above 101.6mm (4") do not require tie rod supports.

All dimensions are in millimetres unless otherwise stated.

Stroke Tolerances

Stroke length tolerances are required due to the build-up of tolerances of piston, head, cap and cylinder body. Standard production stroke tolerances are -0.4 to +0.8mm on all bore sizes and stroke lengths. For closer tolerances, please specify the required tolerance plus the operating temperature and pressure. Stroke tolerances of less than 0.4mm are generally impracticable due to the elasticity of cylinders and, in these cases, the use of a stroke adjuster should be considered – see page 43.

Mounting Bolts

Parker recommends that mounting bolts with a minimum strength of ISO 898/1 grade 10.9 should be used for fixing cylinders to the machine or base. This recommendation is of particular importance where bolts are placed in tension or subjected to shear forces. Mounting bolts should be torque loaded to their manufacturer's recommended figures.

Tie Rod Nuts

Tie rod mounting nuts, with lubricated threads, should be to a minimum strength of ISO 898/2 grade 10, torque loaded to the figures shown.

Bore Ø	Tie Rod Nut Torque Specifications	
	Nm min-max	lb.ft min-max
25.4 (1")	3 - 3.5	2 - 2.5
38.1 (1½")	8 - 9	5 - 6
50.8 (2")	15 - 17	11 - 12
63.5 (2½")		
82.6 (3¼")	33 - 36	25 - 26
101.6 (4")		
127.0 (5")	80 - 85	60 - 64
152.4 (6")		
203.2 (8")	150 - 155	110 - 114

Manifold Ports

Side mounted cylinders (Style C) can be supplied with the cylinder ports arranged for mounting and sealing to a manifold surface. Manifold ports are available with both single- and double-rodged cylinders. The ports are drilled and counterbored for O-ring seals which are provided. With these specifications, the mounting is designated Style CM. Please consult the factory.

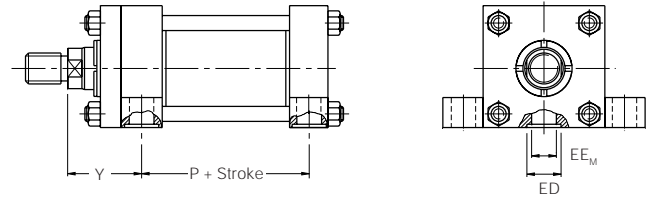

Bore Ø	Rod No.	Y ±0.8	P ±0.8	EE _M	ED	Parker O-Ring No.
25.4 (1")	1	49.2	54.0	9.5	17.5	2 - 015
	2					
38.1 (1½")	1	50.8	54.0	12.7	20.6	2 - 017
	2					
50.8 (2")	1	50.8	54.0	12.7	20.6	2 - 017
	2					
	3					
63.5 (2½")	1	60.3	57.2	12.7	20.6	2 - 017
	2					
	3					
	7					
82.6 (3¼")	1	61.9	66.7	15.9	23.8	2 - 019
	2					
	3					
	4					
101.6 (4")	1	69.3	66.7	15.9	23.8	2 - 019
	2					
	3					
	4					
	7					
127.0 (5")	1	74.6	73.0	15.9	23.8	2 - 019
	2					
	3					
	4					
	5					
	7					
	8					
	152.4 (6")					
2						
3						
4						
5						
6						
7						
203.2 (8")	1	81.0	82.6	22.2	30.2	2 - 023
	2					
	3					
	4					
	5					
	6					
	7					
	8					
	0					

All dimensions are in millimetres unless otherwise stated.

Calculation of Cylinder Diameter

Given that the force and operating pressure of the system are known, and that a piston rod size has been estimated taking account of whether the rod is in tension (pull) or compression (push), then the cylinder bore can be selected.

If the piston rod is in compression, use the 'Push Force' table below, as follows:

1. Identify the operating pressure closest to that required.
2. In the same column, identify the force required to move the load (always rounding up).
3. In the same row, look along to the cylinder bore required.

If the cylinder envelope dimensions are too large for the application, increase the operating pressure, if possible, and repeat the exercise.

If the piston rod is in tension, use the 'Deduction for Pull Force' table. The procedure is the same but, due to the reduced area caused by the piston rod, the force available on the 'pull' stroke will be smaller.

To determine the pull force:

1. Follow the procedure for 'push' applications as described above.
2. Using the 'pull' table, identify the force indicated according to the rod and pressure selected.
3. Deduct this from the original 'push' force. The resultant is the net force available to move the load.

If this force is not large enough, go through the process again but increase the system operating pressure or cylinder diameter if possible. If in doubt, our design engineers will be pleased to assist.

Note: For maximum pressures, please refer to page 40.

inPHorm

For more comprehensive information on the calculation of cylinder bore size required, please refer to the European cylinder inPHorm selection program (HY07-1260/Eur).

Push Force

Bore Ø	Piston Area		Cylinder Push Force in kN						Cylinder Push Force in Pounds Force						Displacement per 10mm Stroke	
	mm ²	sq.in.	5 bar	10 bar	25 bar	70 bar	100 bar	140 bar	80 psi	100 psi	250 psi	1000 psi	1500 psi	2000 psi	Litres	Imp. Galls
25.4 (1")	510	0.785	0.3	0.5	1.3	3.6	5.1	-	65	79	196	785	1177	-	0.0050	0.0011
38.1 (1½")	1140	1.767	0.6	1.1	2.9	8.0	11.4	16.0	142	177	443	1770	2651	3540	0.0114	0.0025
50.8 (2")	2020	3.14	1.0	2.0	5.1	14.1	20.2	28.3	251	314	785	3140	4713	6280	0.0202	0.0044
63.5 (2½")	3170	4.91	1.6	3.2	7.9	22.2	31.7	44.4	393	491	1228	4910	7364	9820	0.0317	0.0070
82.6 (3¼")	5360	8.30	2.7	5.4	13.4	37.5	53.5	75.3	664	830	2075	8300	12450	16600	0.0535	0.0120
101.6 (4")	8110	12.57	4.1	8.1	20.3	56.8	81.1	113.3	1006	1257	3143	12570	18856	25140	0.0811	0.0178
127.0 (5")	12670	19.64	6.4	12.7	31.6	88.5	127	177.3	1571	1964	4910	19640	29460	39280	0.1267	0.0279
152.4 (6")	18240	28.27	9.1	18.3	45.5	128	183	255.3	2262	2827	7068	28270	42406	56540	0.1827	0.0402
203.2 (8")	32430	50.27	16.2	32.5	81.1	227	325	454.7	4022	5027	12568	50270	75406	100540	0.3246	0.0714

Deduction for Pull Force

Piston Rod Ø	Piston Rod Area		Piston Rod Forces in kN						Piston Rod Forces in Pounds Force						Displacement per 10mm Stroke	
	mm ²	sq.in.	5 bar	10 bar	25 bar	70 bar	100 bar	140 bar	80 psi	100 psi	250 psi	1000 psi	1500 psi	2000 psi	Litres	Imp. Galls
12.7 (½")	130	0.196	0.1	0.1	0.3	0.9	1.3	-	16	20	49	196	294	-	0.0013	0.0003
15.9 (⅝")	200	0.307	0.1	0.2	0.5	1.4	2.0	2.8	25	31	77	307	461	614	0.0020	0.0004
25.4 (1")	500	0.785	0.3	0.5	1.3	3.5	5.0	7.0	65	79	196	785	1177	1570	0.0050	0.0011
34.9 (1⅜")	960	1.49	0.5	1.0	2.4	6.8	9.6	13.5	119	149	373	1490	2235	2980	0.0097	0.0021
44.5 (1¾")	1560	2.41	0.8	1.6	3.9	10.9	15.6	21.9	193	241	603	2410	3615	4820	0.0156	0.0034
50.8 (2")	2020	3.14	1.0	2.0	5.1	14.1	20.2	28.3	251	314	785	3140	4713	6280	0.0202	0.0044
63.5 (2½")	3170	4.91	1.6	3.2	7.9	22.2	31.7	44.4	393	491	1228	4910	7364	9820	0.0317	0.0070
76.2 (3")	4560	7.07	2.3	4.6	11.4	32.0	45.6	63.9	566	707	1767	7070	10604	14140	0.0456	0.0100
88.9 (3½")	6210	9.62	3.1	6.2	15.5	43.4	62.0	86.7	770	962	2405	9620	14430	19240	0.0621	0.0137
101.6 (4")	8110	12.57	4.1	8.1	20.3	56.8	81.1	114.0	1006	1257	3143	12570	18856	25140	0.0811	0.0178
127.0 (5")	12670	19.64	6.4	12.7	31.6	88.7	126	177.3	1571	1964	4910	19640	29460	39280	0.1267	0.0279
139.7 (5½")	15330	23.76	7.7	15.3	38.4	107	153	214.7	1901	2376	5940	23760	35640	47520	0.1523	0.0335

All dimensions are in millimetres unless otherwise stated.



Piston Rod Size Selection

The selection of a piston rod for thrust (push) conditions requires the following steps to be carried out:

1. Determine the type of cylinder mounting style and rod end connection to be used. Consult the Stroke Factor table on page 38 and determine which factor corresponds to the application.
2. Using the appropriate stroke factor from page 38, determine the 'basic length' from the equation:

$$\text{Basic Length} = \text{Net Stroke} \times \text{Stroke Factor}$$

(The graph is prepared for standard rod extensions beyond the face of the gland retainers. For rod extensions greater than standard, add the increases to the net stroke to arrive at the 'basic length'.)

3. Calculate the load imposed for the thrust application by multiplying the full bore area of the cylinder by the system pressure, or by referring to the Push and Pull Force charts on page 36.
4. Using the graph below, look along the values of 'basic length' and 'thrust' as found in 2 and 3 above, and note the point of intersection.

Note : When considering the use of long stroke cylinders, the piston rod should be of sufficient diameter to provide the necessary column strength.

The correct piston rod size is read from the diagonally curved line labelled 'Rod Diameter' above the point of intersection.

Stop Tubes

Stop tubes prevent the cylinder from completing its full stroke, to provide a spread between the piston and the rod bearing at full extension. Note that stop tube requirements differ for fixed and pivot mounted cylinders. The required length of stop tube, where necessary, is read from the vertical columns on the right of the graph by following the horizontal band within which the point of intersection lies. If the required length of stop tube is in the region labelled 'consult factory', please supply the following:

1. Cylinder mounting style.
2. Rod end connection and method of guiding load.
3. Bore required, stroke, length of rod extension (dimension W - dimension V - see pages 3 and 46) if greater than standard.
4. Mounting position of cylinder. (Note if at an angle or vertical, and specify the direction of the piston rod.)
5. Operating pressure of cylinder, if limited to less than the standard pressure for the cylinder selected.

For accurate sizing, please refer to the European cylinder inPHorm selection program (HY07-1260/Eur). When specifying a cylinder with a stop tube, please insert an S (Special) and the **net** stroke of the cylinder in the order code and state the length of the stop tube. Note that net stroke is equal to the gross stroke of the cylinder less the length of the stop tube. The gross stroke determines the envelope dimensions of the cylinder.

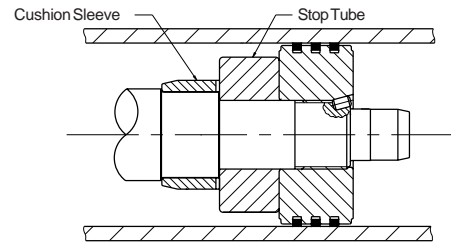

Piston Rod Selection Chart

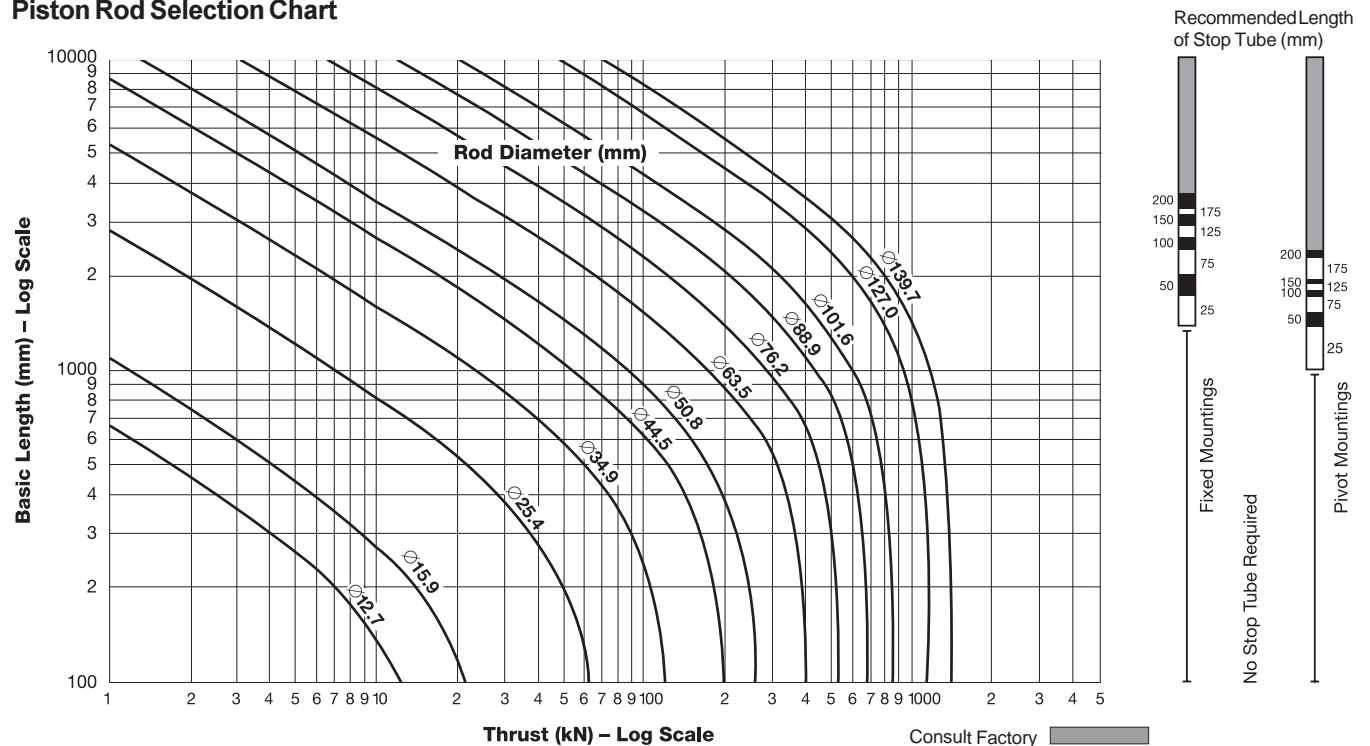

Stroke Factors

Stroke Factors

The stroke factors which follow are used in the calculation of cylinder 'basic length' – see Piston Rod Size Selection, page 37.

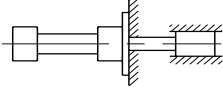
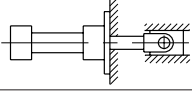
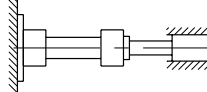
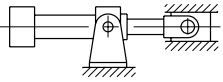
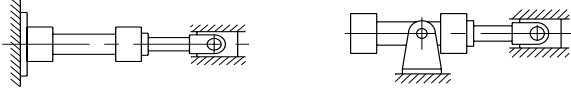
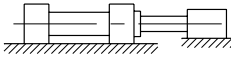
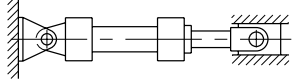
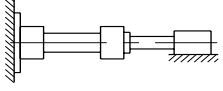
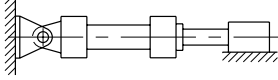
Rod End Connection	Mounting Style	Type of Mounting	Stroke Factor
Fixed and Rigidly Guided	TB, TD, J, JB, C, F, G		0.5
Pivoted and Rigidly Guided	TB, TD, J, JB, C, F, G		0.7
Fixed and Rigidly Guided	TC, H, HB		1.0
Pivoted and Rigidly Guided	D		1.0
Pivoted and Rigidly Guided	TC, H, HB, DD		1.5
Supported but not Rigidly Guided	TB, TD, J, JB, C, F, G		2.0
Pivoted and Rigidly Guided	BB, DB, BC		2.0
Fixed but not Rigidly Guided	TC, H, HB		4.0
Pivoted but not Rigidly Guided	BB, DB, BC		4.0

Long Stroke Cylinders

When considering the use of long stroke cylinders, the piston rod should be of sufficient diameter to provide the necessary column strength.

For tensile (pull) loads, rod strength is unaffected by stroke length.

For long stroke cylinders under compressive loads, the use of stop tubes should be considered, to reduce bearing stress. The Piston Rod Selection Chart on page 37 provides guidance where unusually long strokes are required.

inPHorm

For more comprehensive information on the calculation of cylinder bore size required, please refer to the European cylinder inPHorm selection program HY07-1260/Eur.

An Introduction to Cushioning

Cushioning is recommended as a means of controlling the deceleration of masses, or for applications where piston speeds are in excess of 0.1m/s and the piston will make a full stroke. Cushioning extends cylinder life and reduces undesirable noise and hydraulic shock. Deceleration devices or built-in 'cushions' are optional and can be supplied at the head end, cap end, or at both ends of the cylinder without affecting its envelope or mounting dimensions.

Standard Cushioning

Many forms of cushioning exist, and each has its own specific merits and advantages. Final speed may be adjusted using the cushion screws. Note that cushion performance will be affected by the use of water or high water based fluids. Please consult the factory for details.

Alternative Forms of Cushioning

To complement the standard cushioning, special cushions can be designed to suit applications where the energy to be absorbed exceeds the standard cushion performance. Please consult the factory for further details.

Cushion Calculations

Modelling the cushion performance on uniform deceleration, the formulae below can be used to determine the approximate force developed in the cushion chamber when decelerating a load.

inPHorm

Cushioning requirements can be calculated automatically for individual cylinder/load combinations using the European cylinder inPHorm selection program HY07-1260/Eur.

Formulae

$F = ma + A_d P/10 + mgs \sin \alpha - f$
(for inclined or vertically downward direction of mass)

$F = ma + A_d P/10 - mgs \sin \alpha - f$
(for inclined or vertically upward direction of mass)

Where:

F = total force acting on the cushion chamber in Newtons
m = mass of load in kilogrammes (including piston, rod, and rod end accessories, see table and pages 31 to 33)

a = deceleration in m/s², derived from the formula

$$a = \frac{v^2}{2s \times 10^{-3}}$$

where: v = piston velocity in m/s
s = cushion length in mm

A_d = area acted on by pump pressure in mm² (see page 36)

P = pump pressure in bar

g = acceleration due to gravity = 9.81m/s²

α = angle to the horizontal in degrees

f = friction forces in Newtons = mg x 0.15

Example

The following example shows how to calculate horizontal deceleration (α=0).

Selected bore/rod 127/44.5mm (No. 1 rod)
Pressure = 35 bar
Mass = 2268kg
Velocity = 0.6m/s
Cushion length = 27mm
Friction coefficient = 0.15 or 3337N.

$$F = ma + A_d P/10$$

where a = $\frac{0.6^2}{2 \times 27 \times 10^{-3}} = 6.66 \text{ m/s}^2$

and $F = 2268 \times 6.66 + 12670 \times 35/10 - 3337 = 56128\text{N}$

The total deceleration force is developed by the fluid compressed in the cushion chamber. This pressure is approximately equal to the force divided by the annular area (cylinder bore area - rod area):

$$\frac{56128\text{N}}{12670\text{mm}^2 - 1560\text{mm}^2} = 5.1\text{N/mm}^2 \text{ or } 51 \text{ bar.}$$

This induced pressure should not exceed 135 bar.

Cushion Length & Piston and Rod Mass

Where specified, 3L cylinders incorporate the longest cushion sleeve and spear that can be accommodated within the standard envelope without reducing the rod bearing and piston bearing lengths (see table of cushion lengths below). Cushions are adjustable via recessed needle valves.

Bore Ø	Rod No.	MM Rod Diameter	Cushion Length		Piston & Rod at Zero Stroke (kg)	Rod Only per 10mm Stroke (kg)
			Head	Cap		
25.4 (1")	1	12.7 (1/2")	22.2	19.1	0.18	0.01
	2	15.9 (5/8")			0.23	0.02
38.1 (1 1/2")	1	15.9 (5/8")	22.2	20.6	0.38	0.02
	2	25.4 (1")			0.65	0.04
50.8 (2")	1	15.9 (5/8")	22.2	20.6	0.58	0.02
	2	34.9 (1 3/8")			1.34	0.07
	3	25.4 (1")			0.85	0.04
63.5 (2 1/2")	1	25.4 (1")	22.2	20.6	1.18	0.04
	2	44.5 (1 3/4")			2.43	0.12
	3	34.9 (1 3/8")			1.68	0.07
	4	15.9 (5/8")			0.91	0.02
82.6 (3 1/4")	1	25.4 (1")	28.6	25.4	1.74	0.04
	2	50.8 (2")	20.6		3.71	0.16
	3	34.9 (1 3/8")	28.6		2.26	0.07
	4	44.5 (1 3/4")	28.6		3.04	0.12
101.6 (4")	1	34.9 (1 3/8")	28.6	25.4	2.93	0.07
	2	63.5 (2 1/2")	20.6		6.36	0.25
	3	44.5 (1 3/4")	28.6		3.72	0.12
	4	50.8 (2")	20.6		4.39	0.16
	7	25.4 (1")	20.6		2.42	0.04
127.0 (5")	1	44.5 (1 3/4")	28.6	25.4	5.46	0.12
	2	88.9 (3 1/2")	20.6		12.91	0.48
	3	50.8 (2")	20.6		6.13	0.16
	4	63.5 (2 1/2")	20.6		8.11	0.25
	5	76.2 (3")	20.6		10.48	0.35
	7	25.4 (1")	28.6		4.16	0.04
	8	34.9 (1 3/8")	28.6		4.68	0.07
	152.4 (6")	1	44.5 (1 3/4")		34.9	31.8
2	101.6 (4")	27.0	18.56	0.63		
3	50.8 (2")	27.0	7.88	0.16		
4	63.5 (2 1/2")	27.0	9.91	0.25		
5	76.2 (3")	27.0	12.35	0.35		
6	88.9 (3 1/2")	27.0	14.86	0.48		
7	34.9 (1 3/8")	34.9	6.38	0.07		
203.2 (8")	1	50.8 (2")	27.0	31.8	12.85	0.16
	2	139.7 (5 1/2")	23.8		39.78	1.19
	3	63.5 (2 1/2")	27.0		14.88	0.25
	4	76.2 (3")	27.0		17.31	0.35
	5	88.9 (3 1/2")	27.0		19.83	0.48
	6	101.6 (4")	27.0		23.52	0.63
	7	34.9 (1 3/8")	34.9		11.34	0.07
	8	44.5 (1 3/4")	34.9		12.15	0.12
	0	127.0 (5")	23.8		33.43	0.98

All dimensions are in millimetres unless otherwise stated.

Pressure Limitations – Introduction

The pressure limitations of a hydraulic cylinder must be reviewed when considering its application. To assist the designer in obtaining the optimum performance from a cylinder, the following guidelines are provided. If in doubt, please consult the factory.

Low Pressure Operation

At low operating pressures, a wide range of application factors begin to affect cylinder performance. As a result, consideration should be given to factors such as seal friction and mounting alignment when selecting a cylinder for low pressure use. Low Friction seals are available to special order, to optimise performance at low pressures. For further information, please consult the factory.

Maximum Pressure

Series 3L cylinders are recommended for pressures up to 70 bar with hydraulic oil as the fluid medium. For pressures above those indicated, Series 2H cylinders should be considered. The 4:1 design factor rating shown is conservative for continuous severe applications. Safety factors at other pressures can be calculated from this rating. In addition, mounting styles, stroke, etc., should be considered because of the limiting effect they may have on these ratings.

The designer must, however, take account of fatigue stress which may restrict the cylinder to a lower pressure. Three main areas of cylinder design may be affected: the cylinder body (pressure envelope), the cylinder mountings, and the piston rod.

The maximum pressures indicated in the tables opposite are based on pure tensile and compressive loadings, without the presence of any bending stresses. Where it is impractical to avoid side loadings, eg: by the use of pivot mountings, please consult the factory giving full details of the application.

Cylinder Body (Pressure Envelope)

In many applications, the pressure developed within a cylinder may be greater than the working pressure, due to pressure intensification across the piston and cushioning, eg: meter-out circuits. In most cases, this intensification does not affect the cylinder mountings or piston rod threads in the form of increased loading. This induced pressure should not exceed 135 bar. If in doubt, please consult the factory.

inPHorm

For more comprehensive information about pressure limitations for individual cylinders, please refer to the European cylinder inPHorm selection program (HY07-1260/Eur).

Maximum Pressure Ratings

Bore Ø (with Rod No. 1)	4:1 Design Factor (yield)		Heavy-duty Service	
	(bar)	(psi)	(bar)	(psi)
25.4 (1")	140	2000	105	1500
38.1 (1½")	115	1650	105	1500
50.8 (2")	70	1000	70	1000
63.5 (2½")	80	1180	70	1000
82.6 (3¼")	65	925	70	1000
101.6 (4")	50	700	70	1000
127.0 (5")	50	690	60	850
152.4 (6")	40	560	50	750
203.2 (8")	35	510	40	600

Maximum Pressure for J Mountings

Bore Ø	Style J Mounting – Push Application (Bar)			
	Rod Nos. 1, 7, and 8	Rod No. 2	Rod Nos. 3 and 4	Rod Nos. 5 and 6
25.4 (1")	45	30	-	-
38.1 (1½")	45	25	-	-
50.8 (2")	35	15	25	-
63.5 (2½")	20	10	15	-
82.6 (3¼")	45	25	30	-
101.6 (4")	30	15	25	-
127.0 (5")	20	10	15	15
152.4 (6")	25	15	20	15

For pressures exceeding those shown use mounting JB

All dimensions are in millimetres unless otherwise stated.

Standard Ports

Series 3L cylinders are supplied as standard with R1 size BSPP ports to ISO 228/1, spot faced for sealing washers. Smaller R2 size ports, where demanded by the application, are also available. Parker recommends R1 port sizes for their higher flow rate and piston speed capacity.

Metric threaded ports to DIN 3852 Pt.1 and ISO 6149, or NPTF ports in sizes as shown for BSPP ports, can be supplied if specified. The ISO 6149 port incorporates a raised ring in the spot face for identification.

ISO 6149 Port Identification

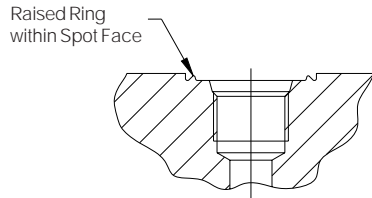

Where required, oversize or additional ports can be supplied on the sides of heads and caps that are not occupied by cushion valves. Refer to the tables of port sizes opposite.

Oversize Ports

For higher speed applications, oversize ports can be supplied in all bore sizes. Ports one size larger than standard are the maximum that can be accommodated in most heads or caps within the standard envelope dimensions. Certain oversize metric, BSPT or NPTF ports require welded port bosses, which protrude from the side of the cylinder. Port sizes are shown in the tables opposite. Note that Y and P dimensions may vary slightly to accommodate oversize ports – please contact the factory where these dimensions are critical.

Port Size and Piston Speed

One of the factors which influences the speed of a hydraulic cylinder is fluid flow in the connecting lines, particularly at the cap end port, due to the absence of a piston rod. Fluid velocity in connecting lines should be limited to 5m/s to minimize fluid turbulence, pressure loss and water hammer effects. The tables opposite are a guide for use when determining whether cylinder ports are adequate for the application. Data shown gives piston speeds for standard and oversize ports and connecting lines where the velocity of the fluid is 5m/s. If the desired piston speed results in a fluid flow in excess of 5m/s in connecting lines, larger lines with two ports per cap should be considered. Parker recommends that a flow rate of 12m/s in connecting lines should not be exceeded.

Speed Limitations

Where large masses are involved, or piston speeds exceed 0.1m/s and the piston will make a full stroke, cushions are recommended – see page 39. For cylinders with oversize ports and with a fluid velocity exceeding 8m/s into the cap end, please consult the factory with details of the application.

Bore Ø	Standard Port					
	Port Size (BSPP)		Port Size Metric	Tube Bore mm	l/min Flow at 5m/sec ¹	Piston Speed in m/sec
	R1	R2				
25.4 (1")	G ¹ / ₄	G ¹ / ₄	M14x1.5	7	11.5	0.42
38.1 (1 1/2")	G ³ / ₈	G ¹ / ₄ ⁴	M14x1.5	8	14.9	0.37
50.8 (2")	G ³ / ₈	G ¹ / ₄ ⁴	M14x1.5	8	14.9	0.21
63.5 (2 1/2")	G ³ / ₈	G ¹ / ₄ ⁴	M14x1.5	8	14.9	0.13
82.6 (3 1/4")	G ¹ / ₂	G ¹ / ₂	M22x1.5	13	40.0	0.12
101.6 (4")	G ¹ / ₂	G ¹ / ₂	M22x1.5	13	40.0	0.08
127.0 (5")	G ¹ / ₂	G ¹ / ₂	M22x1.5	13	40.0	0.05
152.4 (6")	G ³ / ₄	G ³ / ₄	M26x1.5	18	76.2	0.06
203.2 (8")	G ³ / ₄	G ³ / ₄	M26x1.5	18	76.2	0.03

Bore Ø	Oversize Port					
	Port Size (BSPP)		Port Size Metric	Tube Bore mm	l/min Flow at 5m/sec ¹	Piston Speed (m/sec)
	R1	R2				
25.4 (1")	G ³ / ₈	G ³ / ₈	M16x1.5	8	14.9	0.82
38.1 (1 1/2")	G ¹ / ₂ ²	G ³ / ₈ ⁴	M16x1.5	13	40.0	0.56
50.8 (2")	G ¹ / ₂ ²	G ³ / ₈ ⁴	M16x1.5	13	40.0	0.32
63.5 (2 1/2")	G ¹ / ₂ ³	G ³ / ₈ ⁴	M16x1.5	13	40.0	0.20
82.6 (3 1/4")	G ³ / ₄ ³	G ³ / ₄ ³	M26x1.5 ³	18	76.2	0.18
101.6 (4")	G ³ / ₄ ³	G ³ / ₄ ³	M26x1.5 ³	18	76.2	0.12
127.0 (5")	G ³ / ₄ ³	G ³ / ₄ ³	M26x1.5 ³	18	76.2	0.08
152.4 (6")	G1 ³	G1 ³	M33x2 ³	22	113.9	0.10
203.2 (8")	G1 ³	G1 ³	M33x2 ³	22	113.9	0.06

¹ This refers to fluid velocity in connecting lines, not piston velocity
² Requires welded port bosses on both head and cap
³ Requires welded port bosses on cap only
⁴ Tube bore, flow and piston speed data do not apply

Ports, Air Bleeds and Cushion Adjustment Location

The table below shows standard positions for ports, and cushion adjusting screws where fitted. However, by specifying the position numbers for the desired locations for head and cap ports, many mounting styles can be assembled with ports located at 90° or 180° from standard. In these cases, cushion needle and check valves are also repositioned, where fitted, since their relation with the port position does not change. Air bleeds, see page 43, may be fitted in unoccupied faces of the head or cap, depending on mounting.

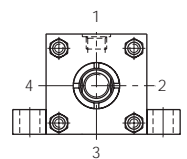

Manifold Ports

Manifold ports are available on all mounting styles to special order. Side mounted cylinders (Style C) can be supplied with the cylinder ports arranged for mounting and sealing to a manifold surface – see page 35.

Positions of Ports and Cushion Screws in Head and Cap	
Head	Port Cushion
Cap	Port Cushion

Mounting Styles																										
TB, TC, TD, J, JB, H & HB				BB, BC				C ⁵	D				DB				DD				G & F					
1	2	3	4	1	2	3	4	1	1	3	1	2	3	4	1	2	3	4	1	2	3	4	1	2	3	4
2	3	4	1	2	3	4	1	2	3	1	3	4	1	2	3	4	1	2	3	4	1	2	2	4	1	3
1	2	3	4	1	3	1	1	2	3	4	1	3	1	2	3	4	1	2	3	4	1	2	3	4		
2	3	4	1	2	4	2	3	4	1	2	3	1	3	4	1	2	3	4	1	2	2	4	1	3		

All dimensions are in millimetres unless otherwise stated.

⁵ Ports in positions 2 and 4 can be fitted. Please consult the factory.

Seals and Fluids

Group	Seal Materials – a combination of:	Fluid Medium to ISO 6743/4-1982	Temperature Range
1	Nitrile (NBR), PTFE, enhanced polyurethane (AU)	Mineral Oil HH, HL, HLP, HLPD ¹ , HM, MIL-H 5606 oil, air, nitrogen	-20°C to +80°C ¹
2	Nitrile (NBR), PTFE	Water glycol (HFC)	-20°C to +60°C
3	Ethylene Propylene (EPR), PTFE	Some phosphate ester fluids Skydrol 500, 700 Class 3 seals are not compatible with hydraulic oil	-23°C to 54°C
4	Special (Nitrile)	Low temperature air or hydraulic oil	-46°C to 66°C
5	Fluorocarbon elastomer (FPM), PTFE	Fire resistant fluids based on phosphate esters (HFD-R) Also suitable for hydraulic oil at high temperatures or in hot environments. Not suitable for use with Skydrol See fluid manufacturer's recommendations	-15°C to +150°C
6	Various compounds including nitrile, enhanced polyurethane, fluorocarbon elastomers and PTFE	Water Oil in water emulsion 95/5 (HFA)	+5°C to +50°C
7		Water in oil emulsion 60/40 (HFB)	+5°C to +50°C

¹ For HLPD fluids where the maximum temperature exceeds 60°C, please contact the factory.

Operating Medium

Sealing materials used in standard cylinders are suitable for use with most petroleum-based hydraulic fluids.

Special seals are available for use with water-glycol or water-in-oil emulsions, and with fluids such as fire-resistant synthetic phosphate ester and phosphate ester-based fluids.

The table above is a guide to the sealing compounds and operating parameters of the materials used for standard and optional rod gland, piston and body seals. If there is any doubt regarding seal compatibility with the operating medium, please consult the factory.

Green Fluids

Special seals for use with specific 'green fluids' are available to special order. Please consult the factory for details.

External Fluids

The environment in which a cylinder is used may cause fluids such as cutting fluids, coolants, and wash down fluids, to come into contact with the external surfaces of the cylinder. These fluids may attack the cylinder O-ring seals, the piston rod wiper and/or the rod seal, and must be taken into account when selecting and specifying seal compounds.

Temperature

Group 1 seals can be operated at temperatures between -20°C and +80°C. Where operating conditions result in temperatures which exceed these limits, special seal compounds may be required to ensure satisfactory service life – please consult the factory.

For seal groups 2, 3, 4, 5, 6 and 7, where operating conditions fall outside of those specified in the table above, please contact the factory.

Optional and Special Seal Designs and Materials

Group 1 seals are fitted as standard to 3L cylinders. For other duties, the optional seal groups 2, 3, 4, 5, 6 and 7 are available – please quote in the cylinder order code, shown on page 47. (Please note that system pressure for Group 6 seals for use with HFA fluids should not exceed 70 bar).

Special seals can also be supplied – please consult the factory with details of the application. Please insert an S (Special) in the order code and specify fluid medium when ordering.

Low Friction Seals

For applications where very low friction and an absence of stick-slip are important, the option of low friction seals is available. Please consult the factory.

Water Service

Special modifications to cylinders are available for high water content fluids. Modifications include a stainless steel piston rod with lipseal piston, and plating of internal surfaces. When ordering, please specify the maximum operating pressure or load/speed conditions, as the stainless steel rod is of lower tensile strength than the standard material.

Pure Water

Parker Hannifin can also supply cylinders for use with pure water as the fluid medium. Please consult the factory.

Warranty Parker Hannifin warrants cylinders modified for water or high water content fluid service to be free of defects in materials or workmanship, but cannot accept responsibility for premature failure caused by excessive wear resulting from lack of lubricity, or where failure is caused by corrosion, electrolysis or mineral deposits within the cylinder.

Filtration

For maximum component life, the system should be protected from contamination by effective filtration. Fluid cleanliness should be in accordance with ISO 4406. The quantity of filters should be in accordance with the appropriate ISO standards.

The rating of the filter medium depends on the system components and the application. The minimum required for hydraulic systems should be class 19/15 to ISO 4406, which equates to 24µ(β10≥75) to ISO 4572.

Air Bleeds

The option of bleed screws, illustrated on page 7, is available at either or both ends of the cylinder, at any position except in the port face – see page 41. The selected positions should be shown in the order code – see page 47.

Stroke Limiters

Where absolute precision in stroke length is required, a screwed adjustable stop can be supplied at the cap end. Several types are available – the illustration shows a design suitable for infrequent adjustment of an uncushioned cylinder. Please contact the factory, specifying details of the application and the adjustment required.

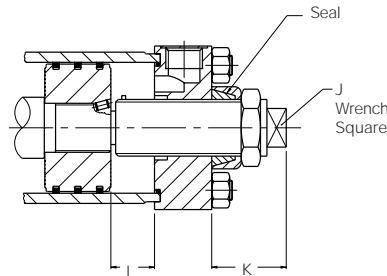

Bore Ø	J	K min.	L max.
38.1 (1½")	11	85	127.0
50.8 (2")	17	85	127.0
63.5 (2½")	17	85	203.2
82.6 (3¼")	17	85	203.2
101.6 (4")	17	85	203.2
127.0 (5")	17	85	228.6
152.4 (6")	22	85	228.6
203.2 (8")	22	85	457.2

Rod Locking Devices

These units provide positive locking of the piston rod. They require hydraulic pressure to release, while loss of pressure causes the clamp to operate, allowing them to be used as a fail-safe device. Please consult the factory for further information.

Single-Acting Cylinders

Standard 3L series cylinders are of the double-acting type. They are also suitable for use as single-acting cylinders, where the load or other external force is used to return the piston after the pressure stroke. Cast iron piston rings should not be used with single-acting cylinders.

Spring-Returned, Single-Acting Cylinders

Series 3L single-acting cylinders can also be supplied with an internal spring to return the piston after the pressure stroke. Please supply details of load conditions and friction factors, and advise whether the spring is required to extend or return the piston rod.

On spring-returned cylinders, it is recommended that tie rod extensions be specified on the cylinder end in which the spring is located to allow the spring to be 'backed off' until compression is relieved. Tie rod nuts should be welded to the tie rods at the opposite end of the cylinder, to further assure safe disassembly. Please consult the factory when ordering spring-returned cylinders.

Multiple Stroke Positioning

To obtain linear force in one plane with controlled stopping at intermediate points, several designs are available. For three stopped positions, it is common practice to mount two standard single rod Style H cylinders back-to-back, or to use through-tie rods. By extending or retracting the stroke of each cylinder independently, it is possible to achieve three positions at the piston ends. An alternative technique is to use a tandem cylinder with an independent piston rod in the cap section. Please consult the factory for further details.

Rod End Bellows

Unprotected piston rod surfaces which are exposed to contaminants with air hardening properties should be protected by rod end bellows. Longer rod extensions are required to accommodate the collapsed length of the bellows. Please consult the factory for further information.

Metallic Rod Wipers

Metallic rod wipers replace the standard wiper seal, and are recommended where dust, ice or splashings might damage the wiper seal material. Metallic rod wipers do not affect cylinder dimensions.

Position Switches

These can be fitted to give reliable end of stroke signals. See catalogue HY07-0810/UK for details.

Position Feedback

Linear position transducers of various types are available for 3L series cylinders. Please consult the factory for further details.

All dimensions are in millimetres unless otherwise stated.

Service Assemblies and Seal Kits

Service Assembly Kits and Seal Kits for 3L cylinders simplify the ordering and maintenance processes. They contain sub-assemblies which are ready for installation, and are supplied with full instructions. When ordering Service Assemblies and Seal Kits, please refer to the identification plate on the cylinder body, and supply the following information:

Serial Number - Bore - Stroke - Model Number - Fluid Type

Key to Part Numbers

- 1 Head
- 7 Cap
- 14 Gland/bearing cartridge
- 15 Cylinder body
- 16 Piston - Cast Iron Ring
- 17 Piston - Lipseal
- 18 Cushion sleeve
- 19 Tie rod
- 23 Tie rod nut
- 27 Retainer

- 60¹ Piston rod – double (weaker²) rod, no cushion
- 61¹ Piston rod – double (weaker²) rod, cushion one end
- 69 O-ring – needle valve and check valve screws
- 69a O-ring – cartridge-type needle valve
- 70 Needle valve, cushion adjustment – bore sizes above 63.5mm (2½")
- 70a Needle valve assembly, cartridge type – bore sizes up to 63.5mm (2½")
- 71 Ball – cushion check valve – bore sizes above 101.6mm (4")
- 72 Cushion check valve screw – bore sizes above 101.6mm (4")
- 73 Floating cushion bush
- 74 Retaining ring for cushion bush

¹ Not illustrated

² See page 30 – double rod strength

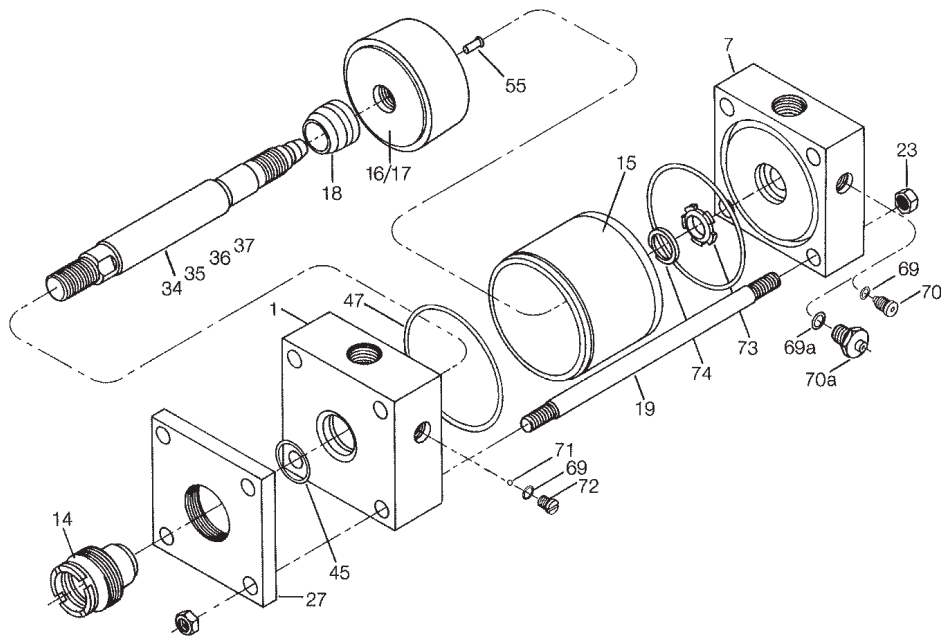

Rod Ø	Gland Cartridge Wrench	Spanner Wrench
12.7	69590	11676
15.9	69590	11676
25.4	69591	11676
34.9	69592	11703
44.5	69593	11677
50.8	69594	11677
63.5	69595	11677
76.2	69596	11677
88.9	69597	11677
101.6	69598	11677
127.0	69599	11678
139.7	69600	11678

- 34 Piston rod – single rod, no cushion
- 35 Piston rod – single rod, cushion at head end
- 36 Piston rod – single rod, cushion at cap end
- 37 Piston rod – single rod, cushion at both ends
- 40 Wiperseal – for gland
- 41 Lipseal – for gland
- 42 Lipseal – for Lipseal piston
- 43 Back-up washer for gland lipseal 41 (Groups 2, 5, 6 & 7 seals)
- 44 Back-up washer for Lipseal piston
- 45 O-ring – gland/head
- 47 O-ring – cylinder body
- 48 Cast iron piston ring
- 55 Locking pin – piston/rod
- 57¹ Piston rod – double (stronger²) rod, no cushion
- 58¹ Piston rod – double (stronger²) rod, cushion one end

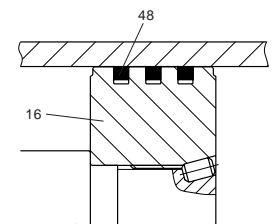

Cast Iron Piston

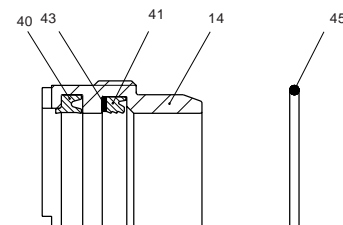

Gland Cartridge and Seals

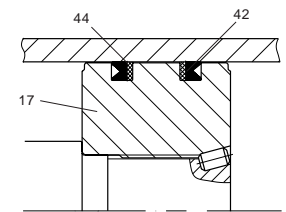

Lipseal Piston

Contents and Part Numbers of Seal Kits for Pistons and Glands

(see key to part numbers opposite)

RG Kit – Gland Cartridge and Seals Contain items 14, 40, 41, 43, 45. Where the original gland incorporates a gland drain, please consult the factory. (Includes RK Kit).

RK Kit – Gland Cartridge Seals Contain items 40, 41, 43, 45.

Rod Diameter mm	RG Kit Standard Gland Cartridge and Seals*	RK Kit Seals for Standard Gland Cartridge*
12.7 (1/2")	RG2HLTS051	RK2HLTS051
15.9 (5/8")	RG2HLTS061	RK2HLTS061
25.4 (1")	RG2HLTS101	RK2HLTS101
34.9 (1 3/8")	RG2HLTS131	RK2HLTS131
44.5 (1 3/4")	RG2HLTS171	RK2HLTS171
50.8 (2")	RG2HLTS201	RK2HLTS201
63.5 (2 1/2")	RG2HLTS251	RK2HLTS251
76.2 (3")	RG2HLTS301	RK2HLTS301
88.9 (3 1/2")	RG2HLTS351	RK2HLTS351
101.6 (4")	RG2HLTS401	RK2HLTS401
127.0 (5")	RG2HLTS501	RK2HLTS501
139.7 (5 1/2")	RG2HLTS551	RK2HLTS551

CB Kit – Cylinder Body End Seals Contains two of item 47.

PR Kit – Piston Rings Contains CB Kit, plus three of item 48.

PK Kit – Piston Lip Seals Contains CB Kit, plus two each of items 42 and 44.

Bore Ø	CB Body Seals *	PR Piston Rings*	PK Piston Seals *
25.4 (1")	CB102HL001	PR103L001	PK102HLL01
38.1 (1 1/2")	CB152HL001	PR153L001	PK152HLL01
50.8 (2")	CB202HL001	PR203L001	PK202HLL01
63.5 (2 1/2")	CB252HL001	PR253L001	PK252HLL01
82.6 (3 1/4")	CB322HL001	PR323L001	PK322HLL01
101.6 (4")	CB402HL001	PR403L001	PK402HLL01
127.0 (5")	CB502HL001	PR503L001	PK502HLL01
152.4 (6")	CB602HL001	PR603L001	PK602HLL01
203.2 (8")	CB802HL001	PR803L001	PK802HLL01

*** Seal Groups – Ordering**

The part numbers shown in the tables above are for Group 1 seals. For Group 2, 3, 4, 5, 6 or 7 seals, substitute 'AHL' for 'HLTS' where used, and substitute a '2', '3', '4', '5', '6' or '7' for the '1' at the end of the number sequence. For example, a Group 5 RG Gland Cartridge Kit for a 50.8mm bore cylinder will be RG2AHL205.

Contents and Part Numbers of Service Assembly Kits

(see key to part numbers opposite)

Head Assembly

Non-cushioned: 1, 47
Cushioned: 1, 47, 69, (69a), 70, (70a), 71, 72

Cap Assembly

Non-cushioned: 7, 47
Cushioned: 7, 47, 69, (69a), 70, (70a), 73, 74

Cylinder Body

All types: 15

Cushion Screw/Cartridge Assembly

Screw type: 69, 70
Cartridge type: 69a, 70a

Check Valve Screw Assembly

Screw type: 69, 71, 72 (bore sizes above 101.6mm)

Piston Rod Assemblies

These kits contain a fully assembled piston and rod assembly which is ready to install. They comprise a piston assembly, plus a rod assembly from the types listed below.

Piston Assemblies

Cast Iron Ring: 16, 48
Lipseal: 17, 42, 44

Rod Assemblies

Single rod, non-cushioned: 34, 55
Single rod, cushioned head: 35, 18, 55
Single rod, cushioned cap: 36, 55
Single rod, cushioned both ends: 37, 18, 55

Double rod, non-cushioned: 57, 60, 55
Double rod, cushioned stronger end: 58, 60, 18, 55
Double rod, cushioned weaker end: 58, 61, 18, 55
Double rod, cushioned both ends: 58, 61, 18 x 2, 55

Tie Rod Torques

Please refer to the table on page 35.

Repairs

Although 3L cylinders are designed to make on-site maintenance or repairs as easy as possible, some operations can only be carried out in our factory. It is standard policy to fit a cylinder returned to the factory for repair with those replacement parts which are necessary to return it to 'as good as new' condition. Should the condition of the returned cylinder be such that repair would be uneconomical, you will be notified.

Notes

Group 1 Seals are manufactured from an enhanced polyurethane material and do not require a gland lipseal back-up washer. These seals provide improved performance in mineral oil applications. They should not be used if the working fluid is water glycol.

Group 6 Seals – System pressure should not exceed 70 bar when using HFA fluids.

All dimensions are in millimetres unless otherwise stated.

**Piston Rod End Data –
 203.2mm (8") bore sizes only**

Piston Rod End Data for 25.4mm to 152.4mm (1" to 6") bore size cylinders is shown on page 3.

Rod End Style 4

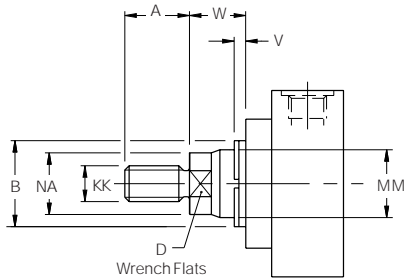

Rod End Style 8

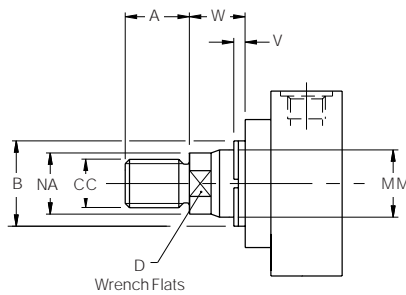

Rod End Style 9

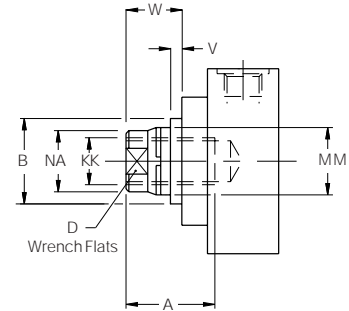

Rod End Styles 4 & 8

Style 4 rod ends are recommended for all applications in which the work piece is secured against the rod shoulder. Where the work piece is not shouldered, Style 8 rod ends are recommended. If rod end style is not specified, Style 4 will be supplied.

Rod End Style 9

For applications where a female thread is required.

Rod End Style 3

Non-standard piston rod ends are designated 'Style 3'.
 A dimensional sketch or description should accompany the order.
 Please specify dimensions KK or CC, and A.

Rod End Dimensions – 203.2mm (8") bore sizes only

Bore Ø	Rod No.	MM Rod Diameter	Style 4 & 9		Style 8		A	+0.00 B -0.05	D	NA	V	W
			KK Metric	KK UNF ¹	CC Metric	CC UNF						
203.2 (8")	1	50.8 (2")	M39x2	1½ - 12	M45x2	1¾ - 12	57.2	66.65	41	49.2	9.5	31.8
	2	139.7 (5½")	M100x2	4 - 12	M130x2	5¼ - 12	139.7	158.72	120	136.5	12.7	38.1
	3	63.5 (2½")	M48x2	1⅞ - 12	M56x2	2¼ - 12	76.2	79.35	55	60.3	12.7	38.1
	4	76.2 (3")	M58x2	2¼ - 12	M68x2	2¾ - 12	88.9	95.22	65	73.0	12.7	38.1
	5	88.9 (3½")	M64x2	2½ - 12	M76x2	3¼ - 12	88.9	107.92	75	85.7	12.7	38.1
	6	101.6 (4")	M76x2	3 - 12	M95x2	3¾ - 12	101.6	120.62	85	98.4	12.7	38.1
	7	34.9 (1⅜")	M26x1.5	1 - 14	M30x2	1¼ - 12	41.3	50.77	30	33.3	6.3	22.2
	8	44.5 (1¾")	M33x2	1¼ - 12	M39x2	1½ - 12	50.8	60.30	36	42.9	9.5	28.6
	0	127.0 (5")	M90x2	3½ - 12	M110x2	4¾ - 12	127.0	146.02	110	123.8	12.7	38.1

¹ All rod threads are UNF except 1" - 14 which is UNS.

All dimensions are in millimetres unless otherwise stated.

How To Order

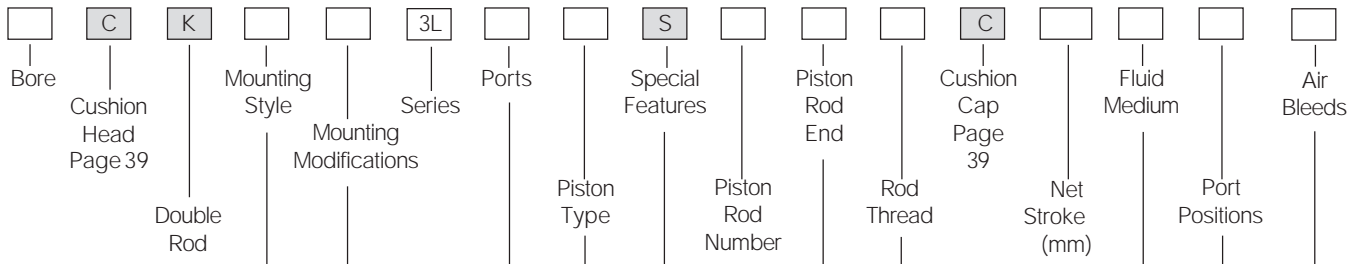

Code	Special Features	Page
S	Oversize Ports	41
S	Rod End Bellows	43
S	Special Seals	42
S	Stop Tube	37
S	Stroke Limiter	43
S	Tie Rod Supports	34
S	Water Service Modifications	42
	- or to customer specification	

Code	Piston	Page
C	Cast Iron Piston Rings (Standard)	7
L	Lipseal	7

Code	Port Style	Page
R1	BSPP thread (R1 sizes)	41
R2	BSPP thread (R2 sizes)	41
G	Metric	41
Y	Metric to ISO 6149	41
U	NPTF (dry seal pipe thread)	41

Code	Modification	Page
P	Thrust Key (Styles C, F, G)	34
M	Manifold Port O-Ring Seal (Style C only)	35

Code	Mounting Style	Page
TB	Tie Rods Extended Head End	10, 22
TC	Tie Rods Extended Cap End	10, 22
TD	Tie Rods Extended Both Ends	10, 22
J	Head Rectangular Flange	12, 24
JB	Head Square Flange	12, 24
H	Cap Rectangular Flange	14, 24
HB	Cap Square Flange	14, 24
C	Side Lug Mounting	16, 26
F	Side Tapped Mounting	16, 26
G	Side End Lug	17, 27
BB	Cap Fixed Clevis	18, 25
BC	Cap Detachable Clevis	18
D	Head Trunnion	20, 28
DB	Cap Trunnion	20, 28
DD	Intermediate Trunnion	20, 28

Code	Fluid Medium	Page
M	Group 1	42
C	Group 2	42
P	Group 3	42
R	Group 4	42
D	Group 5	42
A1	Group 6	42
B	Group 7	42

Code	Port Position	Page
1	Head position 1-4	41
1	Cap position 1-4	41

Code	Air Bleed Position	Page
4	Head position 1-4	43
4	Cap position 1-4	43
00	No air bleeds	43

Code	Thread	Page
M	Metric (standard)	3, 46
A	UNF (optional)	3, 46

Code	Rod End Style	Page
4	Style 4	3, 46
8	Style 8	3, 46
9	Style 9	3, 46
3	Style 3 (Special) - please supply description or drawing	3, 46

Code	Rod Number	Page
eg:1	Select from Rod No. 1, 2, 3, 4, 5, 6, 7, 8 or 0	3, 46

Key

Required for basic cylinder
 Indicate optional features or leave blank

Accessories

Please state on order whether accessories are to be assembled to cylinder or supplied separately.

Double Rod Cylinders – Example

38.1	C	K	J	3L	R1	L	1	4	M	1	4	M	C	127	D	11	44
------	---	---	---	----	----	---	---	---	---	---	---	---	---	-----	---	----	----

Hydraulics Group Sales Offices

Europe

Austria

Wiener Neustadt

Tel: +43 (0)2622 23501 970
Fax: +43 (0)2622 23501 977

Belgium

Nivelles

Parc Industriel Sud-Zone II

Tel: +32 (0)67 280 900
Fax: +32 (0)67 280 999

Czech Republic

Prague

Tel: +420 2 830 85 221
Fax: +420 2 830 85 360

Denmark

Ishøj

Tel: +45 4356 0400
Fax: +45 4373 8431

Finland

Vantaa

Tel: +358 (0)9 4767 31
Fax: +358 (0)9 4767 3200

France

Contamine-sur-Arve

Tel: +33 (0)450 25 80 25
Fax: +33 (0)450 03 67 37

Germany

Kaarst

Tel: +49 (0)2131 4016 0
Fax: +49 (0)2131 4016 9199

Hungary

Budapest

Tel: +36 (06)1 220 4155
Fax: +36 (06)1 422 1525

Ireland

Clonee

Tel: +353 (0)1 801 4010
Fax: +353 (0)1 801 4132

Italy

Corsico (MI)

Tel: +39 02 45 19 21
Fax: +39 02 4 47 93 40

The Netherlands

Oldenzaal

Tel: +31 (0)541 585000
Fax: +31 (0)541 585459

Norway

Ski

Tel: +47 64 91 10 00
Fax: +47 64 91 10 90

Poland

Warsaw

Tel: +48 (0)22 863 49 42
Fax: +48 (0)22 863 49 44

Portugal

Leca da Palmeira

Tel: +351 22 9997 360
Fax: +351 22 9961 527

Slovakia

Ref. Czech Republic

Spain

Madrid

Tel: +34 91 675 73 00
Fax: +34 91 675 77 11

Sweden

Spånga

Tel: +46 (0)8 597 950 00
Fax: +46 (0)8 597 951 10

United Kingdom

Watford (industrial)

Tel: +44 (0)1923 492 000
Fax: +44 (0)1923 256 059

Ossett (mobile)

Tel: +44 (0)1924 282 200
Fax: +44 (0)1924 282 299

International

Australia

Castle Hill

Tel: +61 (0)2-9634 7777
Fax: +61 (0)2-9899 6184

Canada

Milton, Ontario

Tel: +1 905-693-3000
Fax: +1 905-876-0788

China

Beijing

Tel: +86 10 6561 0520
Fax: +86 10 6561 0526

Asia Pacific Group

Hong Kong, Kowloon

Tel: +852 2428 8008
Fax: +852 2425 6896

India

Mumbai

Tel: +91 22 7907081
Fax: +91 22 7907080

Japan

Tokyo

Tel: +(81) 3 6408 3900
Fax: +(81) 3 5449 7201

Latin America Group

Brazil

Tel: +55 12 3954-5100
Fax: +55 12 3954-5266

South Africa

Kempton Park

Tel: +27 (0)11-392 7280
Fax: +27 (0)11-392 7213

USA

Cleveland (industrial)

Tel: +1 216-896-3000
Fax: +1 216-896-4031

Lincolnshire (mobile)

Tel: +1 847-821-1500
Fax: +1 847-821-7600

Parker Hannifin is the world's premier supplier of motion and control systems and solutions, with sales and manufacturing facilities throughout the world. For product information and details of your nearest Parker sales office, visit us at www.parker.com or call free on 00800 2727 5374.



Catalogue HY07-1130/UK
2M 05/03 PD

© Copyright 2003
Parker Hannifin Corporation
All rights reserved.