

Provided with linear pulse encoder

- Combination with a computer or an electronic counter ensures high-accuracy position control and position detection.
- Since a permanent magnet is used for the length measuring roller for detection of distance, the length measuring accuracy is improved.
- Resolution : 0.1 mm/pulse

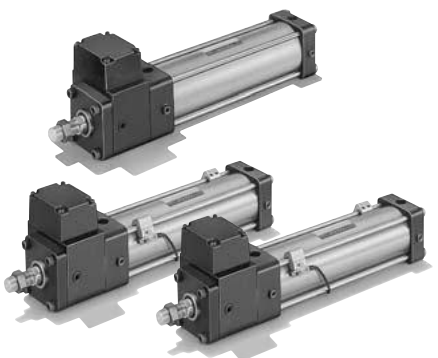

Standard Specifications

Type	Standard type		Switch Set	
	Kind of piston seal	U seal	Slipper Seal	U seal
Nominal pressure	3.5 MPa			
Maximum allowable pressure	4.5 MPa			
Proof test pressure	5 MPa			
Minimum operating pressure	0.2 MPa or less			
Working speed range	8 to 300mm/s	0.1 to 300mm/s	8 to 300mm/s	0.1 to 300mm/s
Working temperature range (ambient temp. and oil temp.)	-10 to +50°C (no freezing)			
Structure of cushioning	Metal fitting system			
Applicable fluid	Petroleum-based fluid (When using another fluid, refer to the table of fluid adaptability.)			
Tolerance for thread	JIS 6g/6H			
Tolerance of stroke	0 to 250mm ^{+0.1} ₀	251 to 1000mm ^{+1.4} ₀	1001 to 1600mm ^{+1.8} ₀	
Tube material	Standard type ● Carbon steel for machine structural use Switch Set ● Stainless steel			
Mounting style	LA · LB · FG · FH · CT			
Accessory	Boots	Standard : Nylon tarpaulin Semi-standard : Chloroprene, Conex		
	Rod end attachment	Rod eye (T-end), rod clevis (Y-end) with pin, floating joint (F-end)		

Cushion Stroke Length

Cylinder bore	Cushion stroke (cushion ring length)
φ32 to φ63	16
φ80 to φ100	20

- The cushion stroke lengths in case of cylinders used up to the stroke end.
- In the case that a cylinder is not used up to the stroke end, and it is stopped 5 mm or more before the stroke end, the cushioning effect will be weakened. In such a case, consult us.

Terminologies

Nominal pressure
Pressure given to a cylinder for convenience of naming. It is not always the same as the working pressure (rated pressure) that guarantees performance under the specified conditions.

Maximum allowable pressure
Maximum allowable pressure generated in a cylinder (surge pressure, etc.).

Proof test pressure
Test pressure against which a cylinder can withstand without unreliable performance at the return to nominal pressure.

Minimum operating pressure
Minimum pressure at which cylinder installed horizontally operates under no load.

- Notes) ● The hydraulic pressure generated in a cylinder due to the inertia of load must be lower than the maximum allowable pressure.
- For the internal structure, refer to the sectional drawings at the end of this catalog.
 - Slipper Seal is the registered trade mark of Nippon Valqua Industries, Ltd.
 - Conex is the registered trademark of Teijin Limited.

Product Lineup

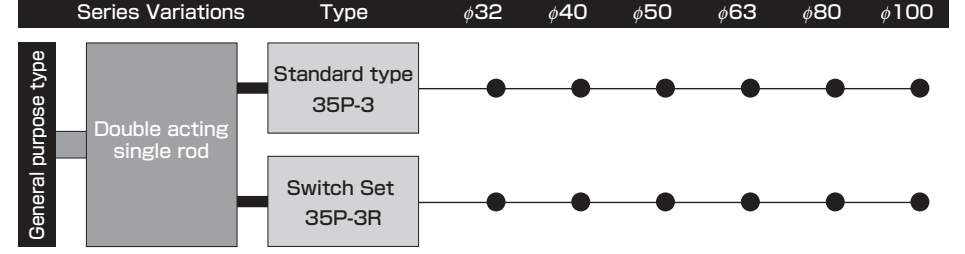

- Notes) ● When using a sensor, use a Switch Set Cylinder.
● No sensor can be mounted onto the standard type cylinder.

Standard type



Switch Set

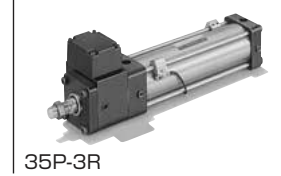

Standard Stroke Range

Unit: mm

Bore	Type	Standard type	Switch Set
	φ32 · φ40		1000
φ50 · φ63		1200	1200
φ80 · φ100		1600	1600

The above strokes indicate the maximum available strokes for the standard type. For the rod buckling, check with the buckling chart in the selection materials. Contact us for longer strokes.

Sensor Mountable Minimum Stroke

Unit: mm

Item	Mounting of 1 sensor		Mounting of 2 sensors	
	AX type	SR type	AX type	SR type
Bore				
φ32				
φ40	25		25	
φ50		35		35
φ63				
φ80	20		20	
φ100				

Adaptability of Fluid to Seal Material

Seal material	Applicable fluid				
	Petroleum-based fluid	Water-glycol fluid	Phosphate ester fluid	Water in oil fluid	Oil in water fluid
Nitrile rubber	○	○	×	○	○

Note) ○ : Applicable × : Inapplicable

Detector Specifications

	Standard	Semi-standard
Power supply voltage	12 V DC	12 to 24 V DC
Output type	12 V DC voltage output Phase A & B (90° phase) 30mA or less	NPN open collector output Phase A & B (90° phase) Applied voltage : 24 V DC or less Sink current : 30mA or less
Resolution	0.1mm/Pulse	
Max. response speed	300mm/s	
Working temperature range	-10 to +50°C (no freezing)	
Note) Length measuring error	0.5mm/m	
Humidity	90%RH (no condensing)	

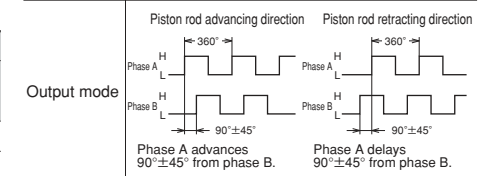
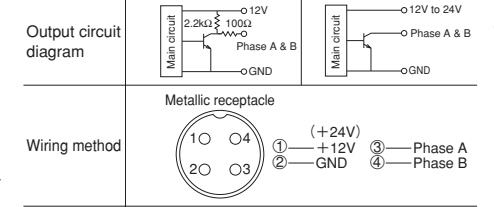
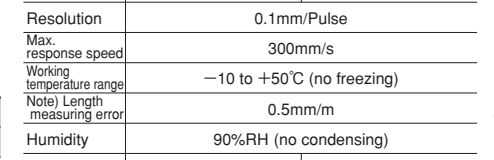

Note) Length measuring error per meter of total moving distance

● How to order

General Purpose Type

● Standard type 35P-3 1 LA 40 B 100

● Switch Set 35P-3R 1 LA 40 B 100 - AH 2 - T - J

1 U seal (nitrile rubber)
B Slipper Seal

J Nylon tarpaulin
JN Chloroprene
JK Conex

Mounting style

Cylinder bore (mm)
φ32 to φ100

B With cushion on both ends
H With cushion on cap side
R With cushion on rod side
N No cushion

Cylinder stroke (mm)

The item enclosed by broken line needs not to be entered, if unnecessary.

Semi-standard specification

1 Type
2 Seal material
3 Mounting style
4 Cylinder bore
5 Cushioning
6 Stroke
7 Sensor symbol
8 Sensor quantity
9 Rod end attachment
10 Boots

T T-end (rod eye)
Y Y-end (rod clevis)
F F-end (floating joint)

Sensor symbol
Note) Select applicable sensors out of the Sensor List.

● Notes on ordering Switch Set

- When no sensor is required, specify 0 for the sensor symbol 7 and the sensor quantity 8.
- Sensors are not mounted on cylinders at delivery.

Standard Stroke Range

Unit: mm

Type	Standard type	Switch Set
φ32 · φ40	1000	1000
φ50 · φ63	1200	1200
φ80 · φ100	1600	1600

The above strokes indicate the maximum available strokes for the standard type. For the rod buckling, check with the buckling chart in the selection materials. Contact us for longer strokes.

Sensor Mountable Minimum Stroke

Unit: mm

Item	Mounting of 1 sensor		Mounting of 2 sensors	
	AX type	SR type	AX type	SR type
φ32				
φ40	25		25	
φ50		35		35
φ63				
φ80	20		20	
φ100				

Mounting Style

LA LA style (side lugs)

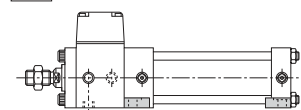

FG FG style (rod flange)

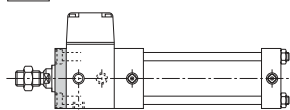

CT CT style (cap eye)

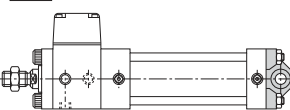

LB LB style (end angles)

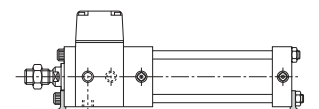

FH FH style (cap flange)

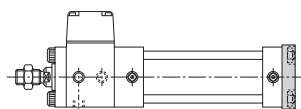

Sensor List

Semi-standard

Type	Sensor symbol	Load voltage range	Load current range	Max. switching capacity	Protective circuit	Indicating lamp	Wiring method	Cord length	Applicable load	
Reed sensor	AF AX101CE	DC : 5 to 30V AC : 5 to 120V	DC : 5 to 40mA AC : 5 to 20mA	DC : 1.5W AC : 2VA	None	LED (Lights in red when sensing)	0.3mm ² , 2-core, outer dia. φ4mm Rear wiring	1.5m	Small relay, programmable controller	
	AG AX105CE							5m		
	AH AX111CE							1.5m		
	AJ AX115CE							5m		
	AE AX125CE	DC : 30V or less AC : 120V or less	DC : 40mA or less AC : 20mA or less	2VA	Provided	None	4-pin connector type Rear wiring	5m		
	AK AX11ACE	AC : 5 to 120V	5 to 20mA					0.5m		
	AL AX11BCE	DC : 5 to 30V	5 to 40mA	1.5W	Provided	LED (Lights in red when not sensing)	0.3mm ² , 2-core, outer dia. φ4mm Rear wiring	0.5m		
	AM AX135CE	AC/DC : 90 to 240V	5 to 300mA	B contact output				5m		
	S SR405	AC : 80 to 220V	2 to 300mA	30VA	Provided	Neon lamp (Lights when not sensing)	0.5mm ² , 2-core, outer dia. φ6mm Rear wiring	5m		
	Solid state sensor	BE AX201CE-1	DC : 5 to 30V	5 to 40mA	—	Provided	LED (Lights in red when sensing)	0.3mm ² , 2-core, outer dia. φ4mm Rear wiring		1.5m
BF AX205CE-1		5m								
CE AX211CE-1		1.5m								
CF AX215CE-1		5m								
CT AX211CE-1		1.5m								
CU AX215CE-1		5m								
CV AX21BCE-1		4-pin connector type Rear wiring							0.5m	
CW AZ211CE-1		0.3mm ² , 2-core, outer dia. φ4mm Upper wiring							1.5m	
CX AZ215CE-1		5m								
CY AZ21BCE-1		4-pin connector type Upper wiring							0.5m	

- (Notes)
- For the sensors without a protective circuit, be sure to provide a protective circuit (SK-100) with the load when using any induction load (relay, etc.).
 - The output logic of AX135CE is a B contact. When the piston is detected, the sensor contact turns off (the lamp turns on).
 - For handling of sensors, be sure to see the sensor specifications at the end of this catalog.

● Standard type

AX type sensor



Cord type



Connector type

SR type sensor



★ Standard specifications

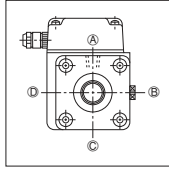

- Both ends cushioned
- Port position (A), cushion valve position (B)
- Detector specification supply voltage : 12 V DC
Output type : 12 V DC, AB-phase output (90° phase)

★ Change of port and cushion valve positions

The standard port position is (A), and the standard cushion valve position is (B). When modifying the positions, enter the symbol shown in the dimensional drawings. (On the standard models, the detector is installed on the top.)

(Example)

35P-3R 1LA40B100-**B** **C** AH2-J

Port position (A, B, C, D)

Cushion valve position (A, B, C, D, or O)

- In case that the cushion is not equipped, the cushion valve position is "O".

★ Semi-standard range

- Change of detector specifications (NPN open collector output)
- With boots
- Change of piston rod end
- Plated cylinder tube (hard chrome plating thickness 0.02 mm)
- Magnetic proximity sensor of SR type

End Lock Nut Part Number

Bore	Number
φ32	LNA-12F-H
φ40	
φ50	LNA-18F-H
φ63	
φ80	LNA-24F-H
φ100	LNA-30F-H

Adaptability of Fluid to Seal Material

Seal material	Applicable fluid				
	Petroleum-based fluid	Water-glycol fluid	Phosphate ester fluid	Water in oil fluid	Oil in water fluid
Nitrile rubber	○	○	×	○	○

Note) ○ : Applicable × : Inapplicable

Unit: mm

Weight Table

Unit: kg

Bore (mm)	Basic weight	Mounting accessory weight					Rod end attachment weight			Additional weight per mm of stroke
	Standard type, Switch Set	LA style	LB style	FG style	FH style	CT style	Rod eye (T-end)	Rod clevis (Y-end) with pin	Floating joint (F-end)	
φ32	3.40	0.12	0.19	0.39	0.51	0.12	0.15	0.20	0.19	0.0041
φ40	3.72	0.19	0.23	0.40	0.58	0.18	0.16	0.34	0.19	0.0045
φ50	5.30	0.28	0.36	0.53	0.86	0.26	0.22	0.35	0.41	0.0078
φ63	7.28	0.29	0.46	0.51	1.15	0.40	0.22	0.35	0.41	0.0094
φ80	11.54	0.66	0.86	1.23	2.27	1.02	0.76	1.01	1.41	0.0122
φ100	17.03	0.96	1.60	1.47	3.26	1.28	1.30	1.76	2.68	0.0200

Calculation formula : Cylinder weight (kg)=basic weight+mounting accessory weight+additional sensor weight+additional weight per mm of stroke×cylinder stroke (mm)

Calculation example : Standard type, LB style, bore φ63, cylinder stroke 200 mm 7.28+0.46+0.0094×200=9.62kg

Sensor Additional Weight

Unit: kg

Sensor	AX type			SR type
	Cord length 1.5 m	Cord length 5 m	With connector	Cord length 1.5 m
φ32	0.05	0.13	0.04	0.22
φ40				
φ50				
φ63				
φ80				
φ100	0.07	0.14	0.06	

Discontinued

PQCPA Series dedicated to analog pulse output position sensing cylinders

- Environmentally-friendly lead-free indicator
- Analog input and pulse input types are available.
- Provided with multi-point output function (5 points) as a standard function to enable to individually set the upper and lower limits Note 1)
- A 16-bit AD converter is provided to realize high resolution. (Analog input type)
- Provided with a counter with a response frequency of 200 kHz (Pulse input type)
- Provided with a pulse position correcting function Note 2)

Note 1) Setting the bank switching enables to use the multi-output function of up to 15 points.

Note 2) Position correction can be made by mounting a cylinder sensor. Positional error caused by slippage of the encoder is eliminated.



Standard Specifications

Type	Analog	Pulse
Model number	PQCPA-CU-A	PQCPA-CU-P
Applicable input signal	Analog voltage/analog current	Phase AB
Display ranges	±999999	
Resolution	Stroke×1/10000	—
Response frequency	1kHz	200kHz
Linearity	±0.02%FS	—
Signals	Voltage input 0 to 10V Voltage input 1 to 5V Current input 4 to 20mA	Open collector input Differential input (line driver input) 12V voltage input 24V voltage input
Monitor output	Voltage output <small>Note)</small>	Line driver output
Sampling speed	1000times/sec	
Display speed	10times/sec	
Display method	Display by fluorescent display tube	
Control input	No-voltage input (reed sensor/solid state sensor) Open collector Max. rating : 50 V DC, 50mA (Provided with multi-point output function (5 points) to enable to individually set the upper and lower limits and pulse position correcting function)	
Power supply voltage	24 V DC ±10%	
Ambient temperature	0 to 50°C (no freezing)	
Ambient humidity	35 to 85%RH (no condensing)	

Note) The monitor output at current input (4 to 20mA) is voltage output of 1 to 5V.

Function Table

Type	Analog input	Pulse input
Model number	PQCPA-CU-A-A	PQCPA-CU-P-12
	PQCPA-CU-A-V	PQCPA-CU-P-24
Functions	—	PQCPA-CU-P-00
	Display of position	Display of position
	Bank switching	Bank switching
	Multi-point output	Multi-point output
	Positional data hold	Positional data hold
	—	0 setting signal
—	Correcting function	

List of Applicable Actuators

Series	Detection method	Signal type
PTN-1B	Absolute method	Analog type (4 to 20mA, 0 to 10V)
PTH-1B		
PTT-1B		Analog type (1 to 5V)
PSR-1A		
35P-3	Linear pulse encoder	Encoder type
70P-8		
140P-8		

Note) For the details of each cylinder, see the section of each series.

● How to order **Discontinued**

Position Indicator

● Analog input

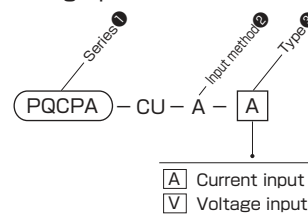

● Pulse input

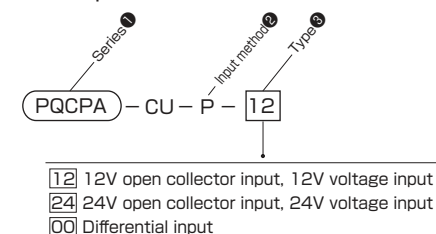

Note) Cylinders do not come with indicators of [00] differential input type. (Specification to use the indicator in stand-alone state)

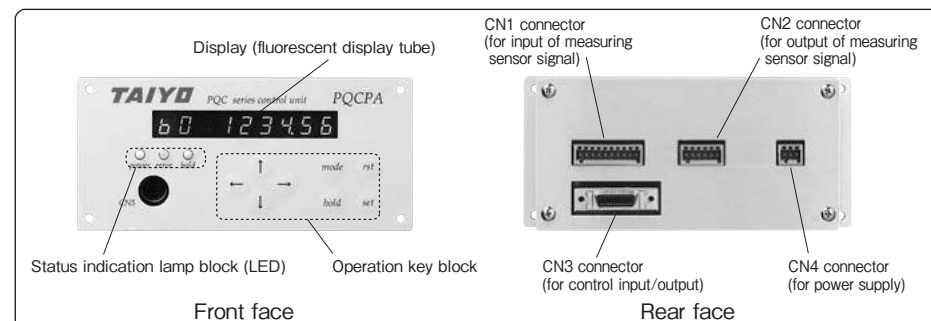

Dimensional Drawings

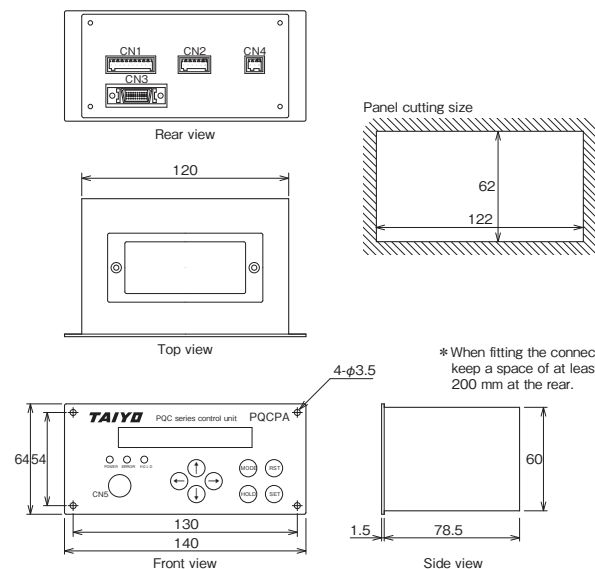

Supplied connector

● CN1 connector (for input of measuring sensor signal)



● CN2 connector (for output of measuring sensor signal)

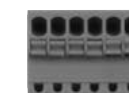

● CN3 connector (for control input/output)



● CN4 connector (for power supply)



* When fitting the connectors, keep a space of at least 200 mm at the rear.

How to order **Discontinued**

How to order cable between sensor and indicator

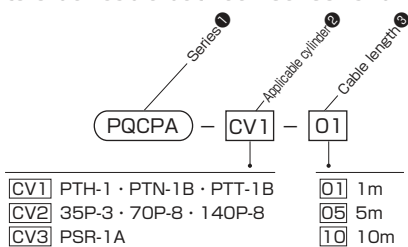

- * When ordering a cable, confirm the series name of the actuator on the sensor side. Some models cannot be connected.
- * After wiring, connect the indicator side connector to the CN1 connector on the indicator.

PQCPA-CV1- Cable length

Applicable actuators : PTH-1B/PTN-1B/PTT-1B

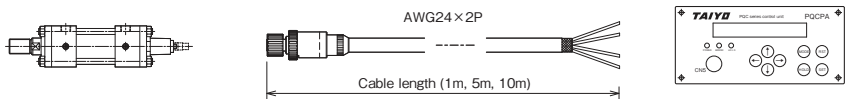

PQCPA-CV2- Cable length

Applicable actuators : 35P-3/70P-8/140P-8

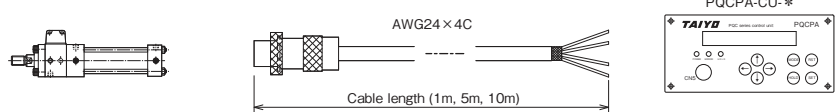

PQCPA-CV3- Cable length

Applicable actuators : PSR-1A

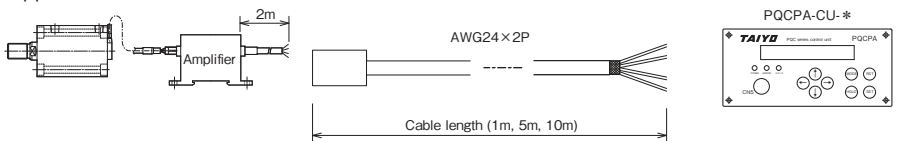

Note) PSR-1A comes with a 2-m cable as a standard accessory. If another cable is required, select this cable. (In this case, disconnect the standard cable (2m) of PSR-1A, and connect the selected cable directly to the amplifier.)

How to order I/O cable

PQCPA - IO

* The I/O cable is 5m long.

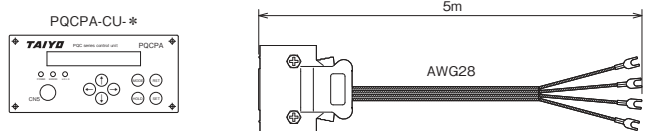

CN3 half-pitch connector
Note) Only the CN3 half-pitch connector is supplied as a standard accessory. If you need the connector with a cable, place an order for the connector.

External devices (programmable controller, etc.)

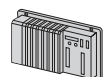

Discontinued

External Input/Output

CN1

Pin No.	Description	Signals
1	Voltage/current input	Analog input
2	NC	—
3	Voltage/current GND	Analog input
4	Phase A	Pulse input
5	-Phase A	Pulse input
6	Phase B	Pulse input
7	-Phase B	Pulse input
8	+24V	Power supply output
9	+12V	Power supply output
10	GND	Power supply output/Phase AB GND

CN2

Pin No.	Description	Signals
1	Pout	Analog output
2	Vss	Analog output
3	A pulse	Pulse output
4	A pulse GND	Pulse output
5	B pulse	Pulse output
6	B pulse GND	Pulse output

CN4

Pin No.	Description	Signals
1	P24	Power supply
2	N24	Power supply
3	PE	Power supply

CN3

Pin No.	Description	Signals
1	0 setting signal	Input
2	Positional data hold	Input
3	Correcting function	Input
4	Bank switching 0	Input
5	Bank switching 1	Input
6	Bank switching 2	Input
7	Reserved input	Input
8	Reserved input	Input
9	Input common	Input
10	Input common	Input
11	Multi-point output signal 0	Output
12	Multi-point output signal 1	Output
13	Multi-point output signal 2	Output
14	Multi-point output signal 3	Output
15	Multi-point output signal 4	Output
16	Reserved output	Output
17	Reserved output	Output
18	Reserved output	Output
19	Output common	Output
20	Output common	Output

* For details, see the instruction manual.

Example of Product Configuration

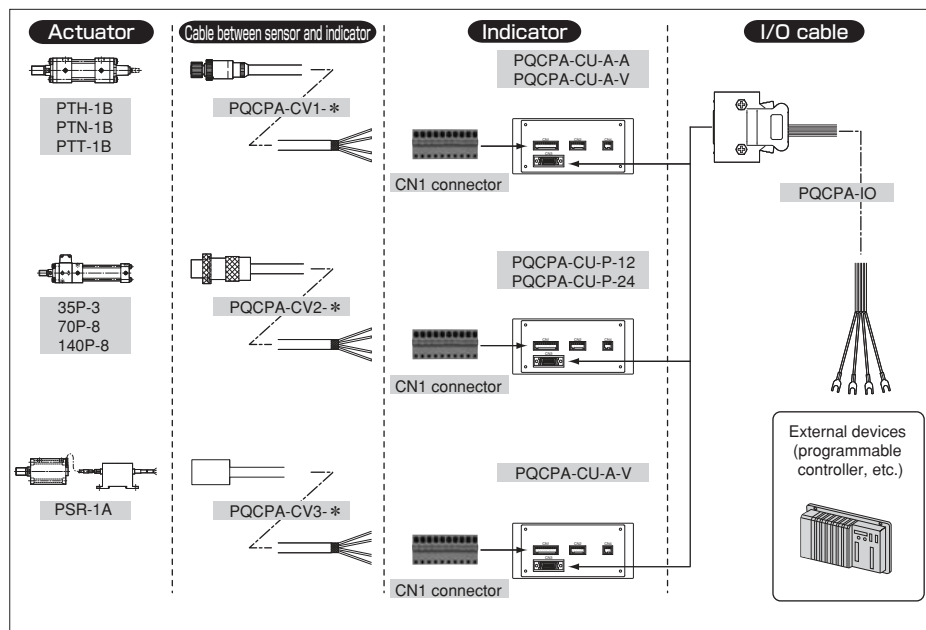

SD

35P-3 1 SD Bore B Stroke

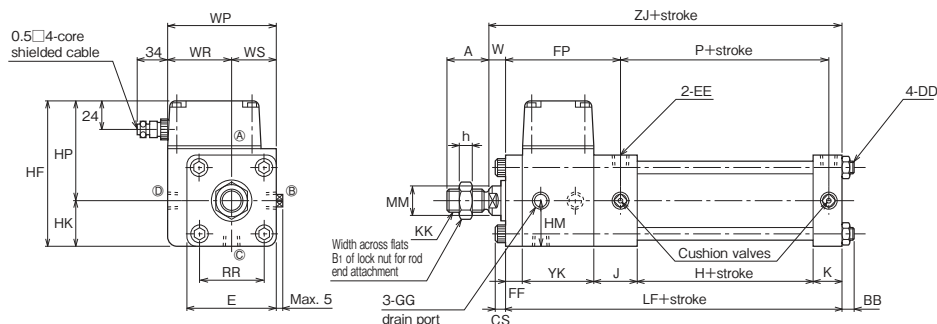
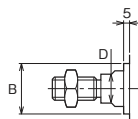

- There are check valves on two sides out of the four outer sides of the cap and rod covers except the port and cushion sides. The check valve is concurrently used with air vent.
- When mounting a sensor, refer to the "dimensional drawings of Switch Set". All the contents other than "sensor mounting dimensions" are the same.

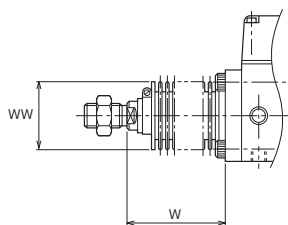

Nylon tarpaulin	φ32 to φ63	1/3 stroke+X
Chloroprene	φ80 and φ100	1/4 stroke+X
Conex	φ32 to φ63	1/2.5 stroke+X
	φ80 and φ100	1/3 stroke+X

	Standard	Semi-standard	
Material	Nylon tarpaulin	Chloroprene	Conex
Heat proof	80°C	130°C	200°C

- Notes
- When the cylinder is provided with boots, the bush is different from that of the standard type cylinder.
 - Remember that the heat proof field in the table above shows the allowable temperatures for the boots, not for the cylinder.
 - Conex is the registered trademark of Teijin Limited.
 - The boots have been mounted at our factory prior to delivery.

- If the calculated value has a fractional part, round it up.

Dimensional Table

Symbol Bore	A	B	B ₁	BB	CS	D	DD	E	EE	FF
φ 32	24	φ 30f9	19	7	6	13	M6×1	□ 44	Rc1/4	15
φ 40	24	φ 30f9	19	7	6	13	M6×1	□ 50	Rc3/8	15
φ 50	36	φ 34f9	24	7	6	19	M6×1	□ 62	Rc3/8	15
φ 63	36	φ 34f9	24	9	8	19	M8×1.25	□ 76	Rc3/8	15
φ 80	48	φ 42f9	32	10	10	24	M10×1.25	□ 94	Rc1/2	20
φ 100	60	φ 50f9	41	12	12	30	M12×1.5	□ 114	Rc1/2	20

Symbol Bore	FP	GG	H	HF	HK	HM	HP	h	J	K
φ 32	99	Rc1/8	30	103	22	19	81	7	38	25
φ 40	99	Rc1/8	30	106	25	22	81	7	38	25
φ 50	99	Rc1/4	30	115	31	31	84	11	38	25
φ 63	99	Rc1/4	33	122	38	38	84	11	38	25
φ 80	107	Rc1/4	31	134	47	47	87	14	45	32
φ 100	113	Rc1/4	31	155	57	57	98	17	45	32

Symbol Bore	KK	LF	MM	P	RR	W	WP	WR	WS	YK	ZJ
φ 32	M12×1.25	168	φ16	58	□ 33	15	80	55	25	60	183
φ 40	M12×1.25	168	φ16	58	□ 37	15	80	55	25	60	183
φ 50	M18×1.5	168	φ22	58	□ 47	15	86	55	31	60	183
φ 63	M18×1.5	171	φ22	61	□ 56	15	93	55	38	60	186
φ 80	M24×2	188	φ28	67	□ 70	19	102	55	47	60	207
φ 100	M30×2	194	φ36	67	□ 89	23	114	57	57	66	217

- The tolerance of MM is f8.
- Dimension HM indicates the drain port position.

With Boots

Symbol Bore	WW	X
φ 32	φ 36	50
φ 40	φ 40	50
φ 50	φ 45	55
φ 63	φ 45	55
φ 80	φ 60	65
φ 100	φ 71	65

LA

35P-3 [1] LA [Bore] B [Stroke]

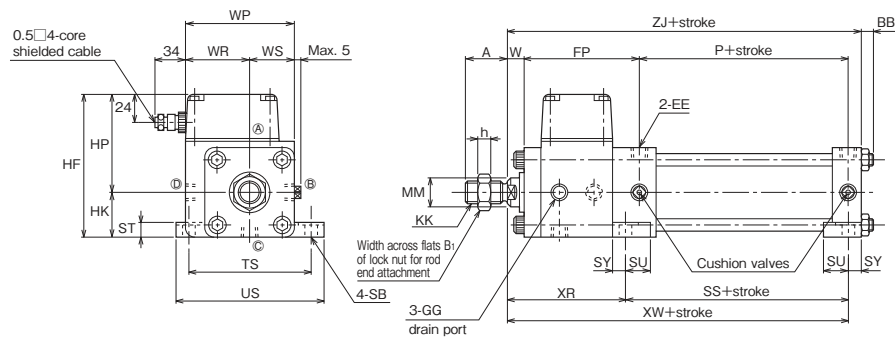
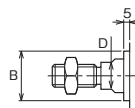

Port position ② Port position ①

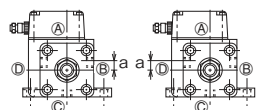

Note) Dimension "a" for port position ② or ①.

Bore	φ 32	φ 40	φ 50	φ 63	φ 80	φ 100
Symbol						
a	5	6	6	0	0	0

• The same applies to the Switch Set Cylinders.

- There are check valves on two sides out of the four outer sides of the cap and rod covers except the port and cushion sides. The check valve is concurrently used with air vent.
- When mounting a sensor, refer to the "dimensional drawings of Switch Set". All the contents other than "sensor mounting dimensions" are the same.

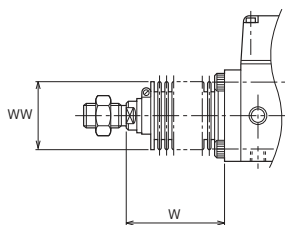

Nylon tarpaulin	φ32 to φ63	1/3 stroke+X
Chloroprene	φ80 and φ100	1/4 stroke+X
Conex	φ32 to φ63	1/2.5 stroke+X
	φ80 and φ100	1/3 stroke+X

• If the calculated value has a fractional part, round it up.

	Standard	Semi-standard	
Material	Nylon tarpaulin	Chloroprene	Conex
Heat proof	80°C	130°C	200°C

- Notes) • When the cylinder is provided with boots, the bush is different from that of the standard type cylinder.
- Remember that the heat proof field in the table above shows the allowable temperatures for the boots, not for the cylinder.
 - Conex is the registered trademark of Teijin Limited.
 - The boots have been mounted at our factory prior to delivery.

Dimensional Table

Symbol	A	B	B ₁	BB	D	EE	FP	GG
Bore								
φ 32	24	φ 30f9	19	7	13	Rc1/4	99	Rc1/8
φ 40	24	φ 30f9	19	7	13	Rc3/8	99	Rc1/8
φ 50	36	φ 34f9	24	7	19	Rc3/8	99	Rc1/4
φ 63	36	φ 34f9	24	9	19	Rc3/8	99	Rc1/4
φ 80	48	φ 42f9	32	10	24	Rc1/2	107	Rc1/4
φ 100	60	φ 50f9	41	12	30	Rc1/2	113	Rc1/4

Symbol	HF	HK	HP	h	KK	MM	P	SB	SS	ST
Bore										
φ 32	103	22	81	7	M12×1.25	φ 16	58	φ 9	73	8
φ 40	106	25	81	7	M12×1.25	φ 16	58	φ 12	73	8
φ 50	115	31	84	11	M18×1.5	φ 22	58	φ 12	73	12
φ 63	122	38	84	11	M18×1.5	φ 22	61	φ 12	76	12
φ 80	134	47	87	14	M24×2	φ 28	67	φ 14	82	19
φ 100	155	57	98	17	M30×2	φ 36	67	φ 18	72	24

Symbol	SU	SY	TS	US	W	WP	WR	WS	XR	XW	ZJ
Bore											
φ 32	18	10	69	84	15	80	55	25	100	173	183
φ 40	24	10	80	100	15	80	55	25	100	173	183
φ 50	24	10	92	112	15	86	55	31	100	173	183
φ 63	24	10	108	128	15	93	55	38	100	176	186
φ 80	32	13	128	150	19	102	55	47	112	194	207
φ 100	27	18	154	182	23	114	57	57	127	199	217

• The tolerance of MM is f8.

With Boots

Symbol	WW	X
Bore		
φ 32	φ 36	50
φ 40	φ 40	50
φ 50	φ 45	55
φ 63	φ 45	55
φ 80	φ 60	65
φ 100	φ 71	65

LB

35P-3 T LB Bore B Stroke

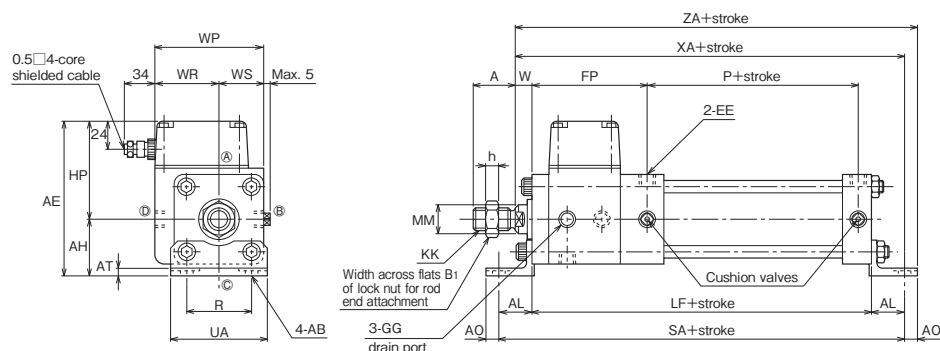
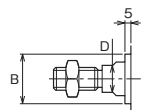

- There are check valves on two sides out of the four outer sides of the cap and rod covers except the port and cushion sides. The check valve is concurrently used with air vent.
- When mounting a sensor, refer to the "dimensional drawings of Switch Set". All the contents other than "sensor mounting dimensions" are the same.

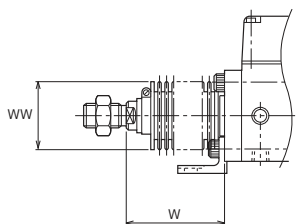

Nylon tarpaulin	φ32 to φ63	1/3 stroke+X
Chloroprene	φ80 and φ100	1/4 stroke+X
Conex	φ32 to φ63	1/2.5 stroke+X
	φ80 and φ100	1/3 stroke+X

- If the calculated value has a fractional part, round it up.

	Standard	Semi-standard	
Material	Nylon tarpaulin	Chloroprene	Conex
Heat proof	80°C	130°C	200°C

- Notes) • When the cylinder is provided with boots, the bush is different from that of the standard type cylinder.
- Remember that the heat proof field in the table above shows the allowable temperatures for the boots, not for the cylinder.
 - Conex is the registered trademark of Teijin Limited.
 - The boots have been mounted at our factory prior to delivery.

Dimensional Table

Symbol Bore	A	AB	AE	AH	AL	AO	AT	B	B ₁
φ 32	24	φ 9	114	33	23	10	5	φ 30f9	19
φ 40	24	φ 12	116	35	25	12	5	φ 30f9	19
φ 50	36	φ 12	125	41	26	12	6	φ 34f9	24
φ 63	36	φ 12	132	48	28	12	6	φ 34f9	24
φ 80	48	φ 14	146	59	34	14	8	φ 42f9	32
φ 100	60	φ 18	168	70	40	18	9	φ 50f9	41

Symbol Bore	D	EE	FP	GG	HP	h	KK	LF	MM
φ 32	13	Rc1/4	99	Rc1/8	81	7	M12×1.25	168	φ 16
φ 40	13	Rc3/8	99	Rc1/8	81	7	M12×1.25	168	φ 16
φ 50	19	Rc3/8	99	Rc1/4	84	11	M18×1.5	168	φ 22
φ 63	19	Rc3/8	99	Rc1/4	84	11	M18×1.5	171	φ 22
φ 80	24	Rc1/2	107	Rc1/4	87	14	M24×2	188	φ 28
φ 100	30	Rc1/2	113	Rc1/4	98	17	M30×2	194	φ 36

Symbol Bore	P	R	SA	UA	W	WP	WR	WS	XA	ZA
φ 32	58	33	214	54	15	80	55	25	206	216
φ 40	58	37	218	60	15	80	55	25	208	220
φ 50	58	47	220	70	15	86	55	31	209	221
φ 63	61	56	227	80	15	93	55	38	214	226
φ 80	67	70	256	97	19	102	55	47	241	255
φ 100	67	89	274	120	23	114	57	57	257	275

- The tolerance of MM is f8.

With Boots

Symbol Bore	WW	X
φ 32	φ 36	50
φ 40	φ 40	50
φ 50	φ 45	55
φ 63	φ 45	55
φ 80	φ 60	65
φ 100	φ 71	65

FG

35P-3 1 FG Bore B Stroke

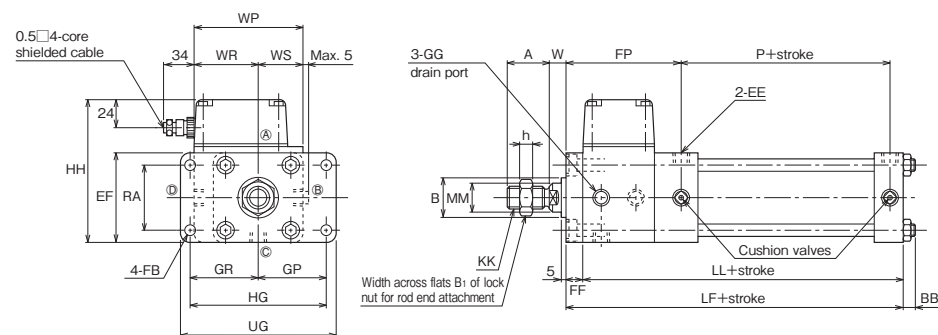
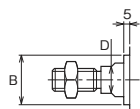

- There are check valves on two sides out of the four outer sides of the cap and rod covers except the port and cushion sides. The check valve is concurrently used with air vent.
- When mounting a sensor, refer to the "dimensional drawings of Switch Set". All the contents other than "sensor mounting dimensions" are the same.

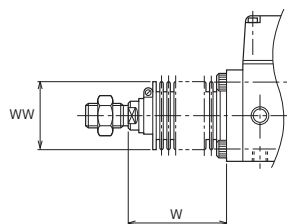

Nylon tarpaulin	φ32 to φ63	1/3 stroke+X
Chloroprene	φ80 and φ100	1/4 stroke+X
Conex	φ32 to φ63	1/2.5 stroke+X
	φ80 and φ100	1/3 stroke+X

• If the calculated value has a fractional part, round it up.

	Standard	Semi-standard	
Material	Nylon tarpaulin	Chloroprene	Conex
Heat proof	80°C	130°C	200°C

- Notes) • When the cylinder is provided with boots, the bush is different from that of the standard type cylinder.
- Remember that the heat proof field in the table above shows the allowable temperatures for the boots, not for the cylinder.
 - Conex is the registered trademark of Teijin Limited.
 - The boots have been mounted at our factory prior to delivery.

Dimensional Table

Symbol Bore	A	B	B ₁	BB	D	EE	EF	FB	FF
φ 32	24	φ 30f9	19	7	13	Rc1/4	47	φ 7	15
φ 40	24	φ 30f9	19	7	13	Rc3/8	52	φ 7	15
φ 50	36	φ 34f9	24	7	19	Rc3/8	65	φ 9	15
φ 63	36	φ 34f9	24	9	19	Rc3/8	76	φ 9	15
φ 80	48	φ 42f9	32	10	24	Rc1/2	95	φ 12	20
φ 100	60	φ 50f9	41	12	30	Rc1/2	115	φ 14	20

Symbol Bore	FP	GG	GP	GR	HG	HH	h	KK
φ 32	99	Rc1/8	35	65	100	104.5	7	M12×1.25
φ 40	99	Rc1/8	35	65	100	107	7	M12×1.25
φ 50	99	Rc1/4	43	67	110	116.5	11	M18×1.5
φ 63	99	Rc1/4	49	66	115	122	11	M18×1.5
φ 80	107	Rc1/4	60	68	128	134.5	14	M24×2
φ 100	113	Rc1/4	70	70	140	155.5	17	M30×2

Symbol Bore	LF	LL	MM	P	RA	UG	W	WP	WR	WS
φ 32	168	153	φ 16	58	33	114	15	80	55	25
φ 40	168	153	φ 16	58	37	114	15	80	55	25
φ 50	168	153	φ 22	58	47	128	15	86	55	31
φ 63	171	156	φ 22	61	56	133	15	93	55	38
φ 80	188	168	φ 28	67	70	152	19	102	55	47
φ 100	194	174	φ 36	67	84	166	23	114	57	57

• The tolerance of MM is f8.

With Boots

Symbol Bore	WW	X
φ 32	φ 36	50
φ 40	φ 40	50
φ 50	φ 45	55
φ 63	φ 45	55
φ 80	φ 60	65
φ 100	φ 71	65

FH

35P-3 **T** FH Bore B Stroke

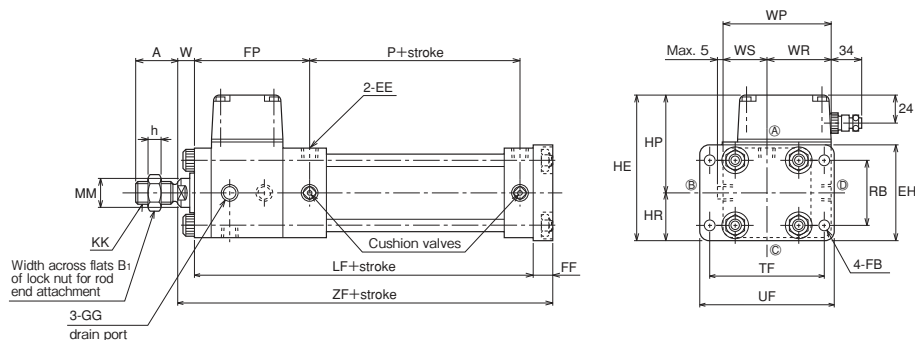
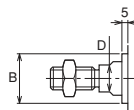

- There are check valves on two sides out of the four outer sides of the cap and rod covers except the port and cushion sides. The check valve is concurrently used with air vent.
- When mounting a sensor, refer to the "dimensional drawings of Switch Set". All the contents other than "sensor mounting dimensions" are the same.

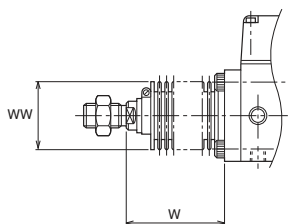

Nylon tarpaulin	φ32 to φ63	1/3 stroke+X
Chloroprene	φ80 and φ100	1/4 stroke+X
Conex	φ32 to φ63	1/2.5 stroke+X
	φ80 and φ100	1/3 stroke+X

• If the calculated value has a fractional part, round it up.

	Standard	Semi-standard	
Material	Nylon tarpaulin	Chloroprene	Conex
Heat proof	80°C	130°C	200°C

- Notes) • When the cylinder is provided with boots, the bush is different from that of the standard type cylinder.
- Remember that the heat proof field in the table above shows the allowable temperatures for the boots, not for the cylinder.
 - Conex is the registered trademark of Teijin Limited.
 - The boots have been mounted at our factory prior to delivery.

Dimensional Table

Symbol Bore	A	B	B ₁	D	EE	EH	FB	FF
φ 32	24	φ 30f9	19	13	Rc1/4	56	φ 7	15
φ 40	24	φ 30f9	19	13	Rc3/8	60	φ 7	15
φ 50	36	φ 34f9	24	19	Rc3/8	70	φ 9	15
φ 63	36	φ 34f9	24	19	Rc3/8	84	φ 9	15
φ 80	48	φ 42f9	32	24	Rc1/2	103	φ 12	20
φ 100	60	φ 50f9	41	30	Rc1/2	125	φ 14	20

Symbol Bore	FP	GG	HE	HP	HR	h	KK	LF
φ 32	99	Rc1/8	109	81	28	7	M12×1.25	168
φ 40	99	Rc1/8	111	81	30	7	M12×1.25	168
φ 50	99	Rc1/4	119	84	35	11	M18×1.5	168
φ 63	99	Rc1/4	126	84	42	11	M18×1.5	171
φ 80	107	Rc1/4	138.5	87	51.5	14	M24×2	188
φ 100	113	Rc1/4	160.5	98	62.5	17	M30×2	194

Symbol Bore	MM	P	RB	TF	UF	W	WP	WR	WS	ZF
φ 32	φ 16	58	42	64	78	15	80	55	25	198
φ 40	φ 16	58	46	68	82	15	80	55	25	198
φ 50	φ 22	58	47	86	104	15	86	55	31	198
φ 63	φ 22	61	56	98	116	15	93	55	38	201
φ 80	φ 28	67	70	119	143	19	102	55	47	227
φ 100	φ 36	67	84	140	166	23	114	57	57	237

• The tolerance of MM is f8.

With Boots

Symbol Bore	WW	X
φ 32	φ 36	50
φ 40	φ 40	50
φ 50	φ 45	55
φ 63	φ 45	55
φ 80	φ 60	65
φ 100	φ 71	65

CT

35P-3 1 CT Bore B Stroke

● $\phi 32$ to $\phi 80$

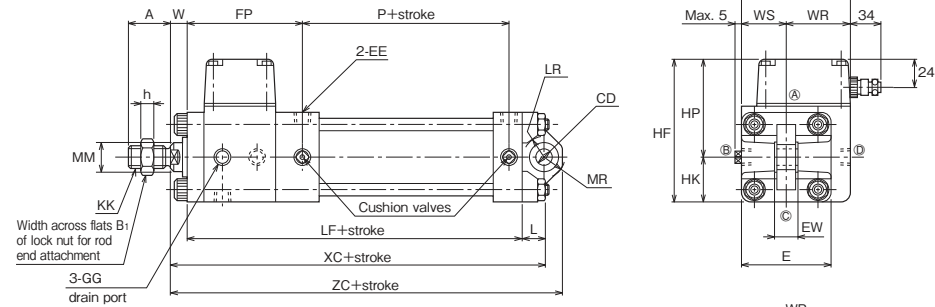

● $\phi 100$

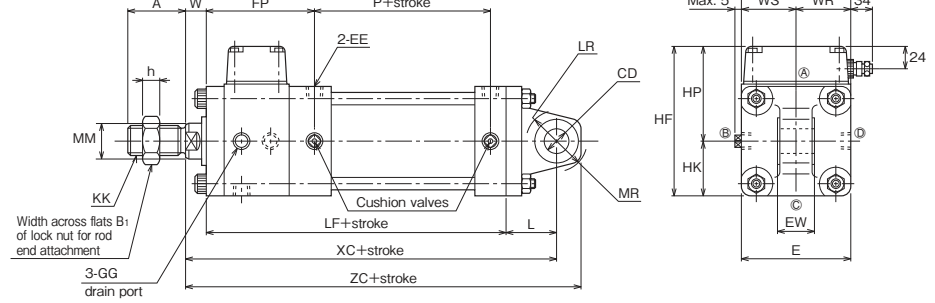

- There are check valves on two sides out of the four outer sides of the cap and rod covers except the port and cushion sides. The check valve is concurrently used with air vent.
- When mounting a sensor, refer to the "dimensional drawings of Switch Set". All the contents other than "sensor mounting dimensions" are the same.

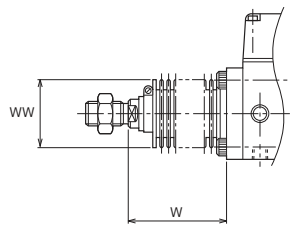

Nylon tarpaulin	$\phi 32$ to $\phi 63$	1/3 stroke+X
	$\phi 80$ and $\phi 100$	1/4 stroke+X
Chloroprene	$\phi 32$ to $\phi 63$	1/2.5 stroke+X
	$\phi 80$ and $\phi 100$	1/3 stroke+X

● If the calculated value has a fractional part, round it up.

	Standard	Semi-standard	
Material	Nylon tarpaulin	Chloroprene	Conex
Heat proof	80°C	130°C	200°C

- Notes) ● When the cylinder is provided with boots, the bush is different from that of the standard type cylinder.
- Remember that the heat proof field in the table above shows the allowable temperatures for the boots, not for the cylinder.
 - Conex is the registered trademark of Teijin Limited.
 - The boots have been mounted at our factory prior to delivery.

Dimensional Table

Symbol	A	B	B ₁	CD	D	E	EE
Bore $\phi 32$	24	$\phi 30f9$	19	$\phi 12H9$	13	$\square 44$	Rc1/4
$\phi 40$	24	$\phi 30f9$	19	$\phi 14H9$	13	$\square 50$	Rc3/8
$\phi 50$	36	$\phi 34f9$	24	$\phi 14H9$	19	$\square 62$	Rc3/8
$\phi 63$	36	$\phi 34f9$	24	$\phi 14H9$	19	$\square 76$	Rc3/8
$\phi 80$	48	$\phi 42f9$	32	$\phi 20H9$	24	$\square 94$	Rc1/2
$\phi 100$	60	$\phi 50f9$	41	$\phi 25H9$	30	$\square 114$	Rc1/2

Symbol	EW	FP	GG	HF	HK	HP	h	KK
Bore $\phi 32$	$16_{-0.07}^0$	99	Rc1/8	103	22	81	7	M12×1.25
$\phi 40$	$20_{-0.084}^0$	99	Rc1/8	106	25	81	7	M12×1.25
$\phi 50$	$20_{-0.084}^0$	99	Rc1/4	115	31	84	11	M18×1.5
$\phi 63$	$20_{-0.084}^0$	99	Rc1/4	122	38	84	11	M18×1.5
$\phi 80$	$32_{-0.1}^0$	107	Rc1/4	134	47	87	14	M24×2
$\phi 100$	$40_{-0.1}^0$	113	Rc1/4	155	57	98	17	M30×2

Symbol	L	LF	LR	MM	MR	P	W	WP	WR	WS	XC	ZC
Bore $\phi 32$	19	168	R12	$\phi 16$	R14	58	15	80	55	25	202	216
$\phi 40$	19	168	R17	$\phi 16$	R16	58	15	80	55	25	202	216
$\phi 50$	19	168	R19	$\phi 22$	R16	58	15	86	55	31	202	216
$\phi 63$	19	171	R19	$\phi 22$	R16	61	15	93	55	38	205	219
$\phi 80$	32	188	R26	$\phi 28$	R22	67	19	102	55	47	239	259
$\phi 100$	53	194	R32	$\phi 36$	R30	67	23	114	57	57	270	295

● The tolerance of MM is f8.

With Boots

Symbol	WW	X
Bore $\phi 32$	$\phi 36$	50
$\phi 40$	$\phi 40$	50
$\phi 50$	$\phi 45$	55
$\phi 63$	$\phi 45$	55
$\phi 80$	$\phi 60$	65
$\phi 100$	$\phi 71$	65

Switch Set

35P-3R 1 Mounting style Bore B Stroke — Sensor symbol Sensor quantity

- AX1** (reed sensor) · AX2** (solid state sensor)

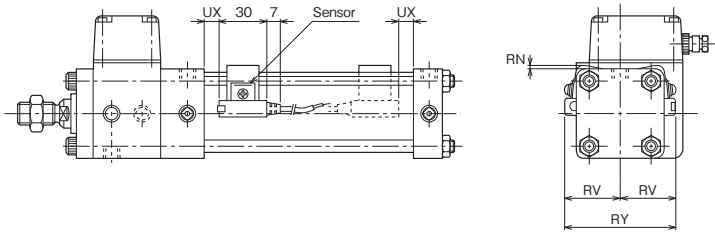

- SR type (reed sensor)

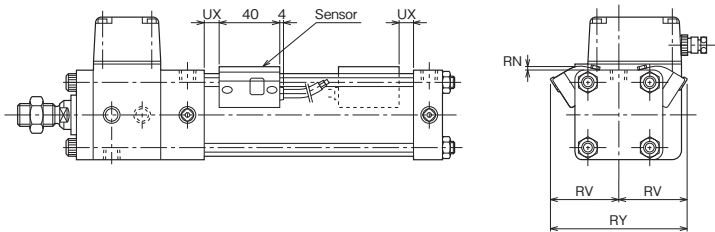

- All dimensions of the cylinders are the same as those of the standard type.

Dimensional Table

Symbol Bore	RN		RV		RY		UX	
	AX type	SR type	AX type	SR type	AX type	SR type	AX type	SR type
φ 32	7	5	34	37	68	74	5	2
φ 40	5	4	36	40	72	80	5	2
φ 50	4	4	41	45	82	90	5	2
φ 63	3	4	47	51	94	102	6	3
φ 80	3	3	54	59	108	118	4	2
φ 100	4	1	63	68	126	136	4	2

Note) Dimension UX indicates the optimum sensor mounting position for detection of stroke end.

Operating Range and Hysteresis

Symbol Bore	Reed sensor				Solid state sensor	
	AX1**		SR type		AX2**	
	Operating range	Hysteresis	Operating range	Hysteresis	Operating range	Hysteresis
φ 32	3 to 6	1 or less	7 to 10	3 or less	5 to 10	1 or less
φ 40					7 to 11	
φ 50			9 to 12		7 to 11	
φ 63	3 to 7	1 or less	9 to 12	3 or less	8 to 12	1 or less
φ 80					7 to 11	
φ 100	4 to 7	1 or less	9 to 12	3 or less	8 to 12	1 or less

Rod End Attachment

● Rod eye (T-end)

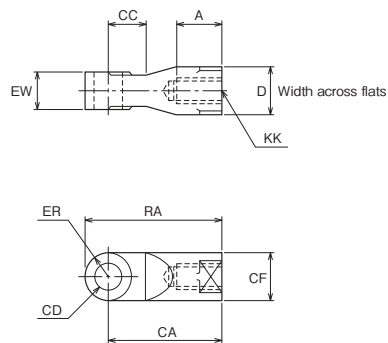

● Rod clevis (Y-end) with pin

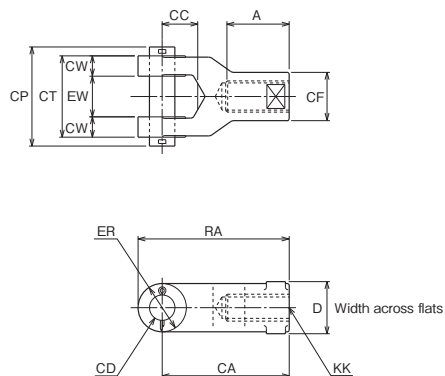

● Floating joint (F-end)

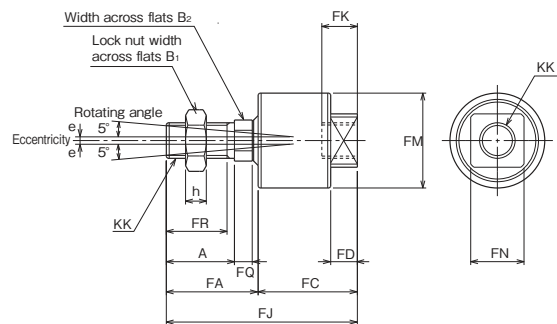

- Notes
- The insertion of the floating joint into the socket shall not equal or exceed the dimension of screw diameter. (Return the joint one or two turns after it gets into contact with the socket bottom, and fix it with a lock nut.) Excessive insertion can cause operation failure.
 - DO NOT use together with CT accessory.
 - The lock nut is indispensable in using the floating joint. Please don't miss to order the lock nut with the floating joint.

Dimensional Table/Rod eye (T-end)

Symbol	Part number	A	CA	CC	CD	CF	D	ER	EW	KK	RA
Bore											
φ 32	RTA-12-1-H	25	55	20	φ12H9	φ24	24	R12	16 ⁰ _{-0.07}	M12×1.25	67
φ 40	RTA-12-H	25	60	20	φ14H9	φ24	24	R12	20 ⁰ _{-0.1}	M12×1.25	72
φ 50	RTA-18-H	37	64	18	φ14H9	φ28	30	R14	20 ⁰ _{-0.1}	M18×1.5	78
φ 63											
φ 80	RTA-24-H	49	100	30	φ20H9	φ38	41	R19	32 ⁰ _{-0.1}	M24×2	119
φ 100	RTA-30-H	61	110	37	φ25H9	φ48	50	R24	40 ⁰ _{-0.1}	M30×2	134

Dimensional Table/Rod clevis (Y-end) with pin

Symbol	Part number	A	CA	CC	CD	CF	CP	CT	CW	D	ER	EW	KK	RA
Bore														
φ 32	RYA-12-2-H	25	55	20	φ12H ^{H9} / _{R8}	φ24	46	32	8	24	R12	16 ^{+1.5} _{+0.5}	M12×1.25	67
φ 40	RYA-12-1-H	25	60	20	φ14H ^{H9} / _{R8}	φ24	58	44	12	24	R12	20 ^{+1.5} _{+0.5}	M12×1.25	72
φ 50	RYA-18-H	37	64	18	φ14H ^{H9} / _{R8}	φ28	58	44	12	30	R14	20 ^{+1.5} _{+0.5}	M18×1.5	78
φ 63														
φ 80	RYA-24-H	49	100	28	φ20H ^{H9} / _{R8}	φ38	78	64	16	41	R19	32 ^{+1.5} _{+0.5}	M24×2	119
φ 100	RYA-30-H	61	110	35	φ25H ^{H9} / _{R8}	φ48	94	80	20	50	R24	40 ^{+1.5} _{+0.5}	M30×2	134

Dimensional Table/Floating joint (F-end)

Symbol	Part number	A	B ₁	B ₂	e	FA	FC	FD	FJ	FK	FM	FN	FQ	FR	h	KK
Bore																
φ 32	RFH-12	24	19	13	1	33	36.5	11	69.5	13.5	φ32	19	7	20.5	7	M12×1.25
φ 40																
φ 50	RFH-18	35	24	19	1.5	46	46	13	92	16	φ40	24	8	31	11	M18×1.5
φ 63																
φ 80	RFH-24-2	46	32	24	2.5	62	67	18	129	24	φ64	36	12	41	14	M24×2
φ 100	RFH-30-2	58	41	32	2.5	78	83	21	161	30	φ76	46	14	52	17	M30×2

Parallel Pin

- $\phi 32$ to $\phi 100$

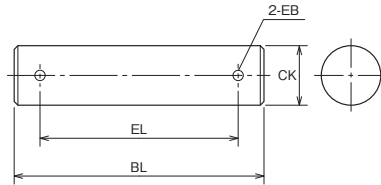

Dimensional Table

Symbol Bore	BL	CK	EB	EL	Nominal of split pin
$\phi 32$	46	$\phi 12$	$\phi 3$	37	3
$\phi 40$	58	$\phi 14$	$\phi 3$	49	3
$\phi 50$	58	$\phi 14$	$\phi 3$	49	3
$\phi 63$	58	$\phi 14$	$\phi 3$	49	3
$\phi 80$	78	$\phi 20$	$\phi 3$	71	3
$\phi 100$	94	$\phi 25$	$\phi 3$	87	3

- The tolerance of CK is f8.