

10 MPa double-acting hydraulic cylinder with size conforming to ISO standards

- 10 MPa double-acting hydraulic cylinder with bores from 32 mm to 125 mm.
- Designed to ISO 10762 cylinder (conforming to JIS B8367-5).
- Adoption of floating cushion allows smooth start.
- High-performance cushion.
- Packing grooves in sliding sections conform to ISO standards



Standard specifications

Types	Standard type, switch set
Nominal pressure	10 MPa
Maximum allowable pressure	Types other than TC type: 10 MPa TC type: 10 MPa ($\phi 63$ or less), 7MPa ($\phi 80$ or more)
Proof test pressure	15MPa
Minimum working pressure	Head side: 0.3 MPa or less Rod side: 0.45 MPa or less
Operating speed range	$\phi 32 - \phi 63$: 8 - 400 mm/s $\phi 80 - \phi 125$: 8 - 300 mm/s
Temperature range (ambient temperature)	Standard type : $-10 - + 80^{\circ}\text{C}$ Switch set : $-10 - + 70^{\circ}\text{C}$ (Free from freezing)
Structure of cushioning	Metal fitting system
Adaptable working oil	Petroleum-based fluid (When using other fluids, refer to the table showing applicability of fluids.)
Tolerance of thread	JIS 6g/6H
Tolerance of stroke	250 mm or less $\begin{matrix} +1.0 \\ 0 \end{matrix}$ 251 - 1000 mm $\begin{matrix} +1.4 \\ 0 \end{matrix}$ 1001 - 2000 mm $\begin{matrix} +1.8 \\ 0 \end{matrix}$
Mounting type	SD • FA • FB • EA • EB • LA • CA • CB • TA • TC
Rod series	Rod B
Accessories	<ul style="list-style-type: none"> ● Rod end eye (T-end) ● Rod end clevis (Y-end) with pin ● Lock nut ● Boots : Nylon tarpaulin : Chloroprene : Conex

- The maximum allowable pressures for the TC type are applicable when load is applied to only one side with the TC positioned in the center.

Terminologies

Nominal pressure

Pressure given for a cylinder for convenience of naming. It is not always the same as the operating pressure (rated pressure) that guarantees performance under the specified conditions.

Maximum allowable pressure

The maximum allowable pressure generated in a cylinder (surge pressure, etc.)

Proof test pressure

Test pressure against which a cylinder can withstand without unreliability performance at the return to nominal pressure.

Minimum working pressure

The minimum pressure that the cylinder placed horizontally without a load can work.

Notes) ● The cylinder with 32 mm bore conforms to JIS B8367-6.

- Rod series B and port Rc conform to JIS B8367 (not included in ISO 10762 standards for body).
- Appropriate temperature range depends on the packing material. For details, refer to the selection materials.
- In case that the lock nut is attached to the piston rod end thread part, lengthen the thread length (dimension A).
- Mounting dimensions of the CA mounting style cylinder differ from those of the standard type.
- As for the EA mounting style cylinder with 63 mm bore, only the length of centering guide (dimension F) differs from that of the standard type.
- Conex, material of the boots, is the trademark of Teijin, Ltd.

- Models and mounting dimensions shown below are not specified in JIS B8367-5.
- Double rod type (100H-2D, 100H-2RD)
- Cutting oil proof type (100HW-2, 100HW-2R)
- Mounting styles SD, FA, and FB

Lines

Unit : mm

Structure		Type	Rod dia.	φ32	φ40	φ50	φ63	φ80	φ100	φ125
General purpose type	Double Acting Single Rod	Standard type 100H-2	Rod B	●	●	●	●	●	●	●
		Switch set 100H-2R	Rod B	●	●	●	●	●	●	●
	Double Acting Double Rod	Standard type 100H-2D	Rod B	●	●	●	●	●	●	●
		Switch set 100H-2RD	Rod B	●	●	●	●	●	●	●
Cutting oil proof type	Double Acting Single Rod	Switch set 100HW-2	Rod B	●	●	●	●	●		
		Switch set 100HW-2R	Rod B	●	●	●	●	●		

- (Notes)
- When using a switch, use a switch set cylinder.
 - No switch can be mounted onto the standard type cylinder.

Double Acting Single Rod



Standard type
(100H-2 · 100HW-2)



Switch set
(100H-2R · 100HW-2R)

Double Acting Double Rod



Standard type
(100H-2D)



Switch set
(100H-2RD)

Standard stroke fabrication range Unit : mm

Bore	Stroke
φ32 · φ40	- 1200
φ50 · φ63	-1400
φ80	- 1600
φ100	- 1800
φ125	- 2000

Cushion stroke length Unit : mm

Bore	Cushion ring length L	Cushion ring parallel part length Le
φ32	21	6
φ40 · φ50	23	6
φ63 - φ125	25	6

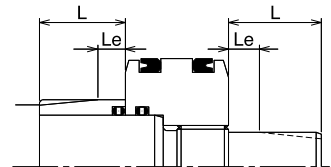

- The strokes above indicate the maximum available strokes for the standard type. If you request larger strokes than those in the table above, contact us.
- For the rod buckling, check with the buckling chart in the selection materials.
- Figures shown in the table above indicate the cushion stroke lengths in the case of cylinders used up to the stroke end.
- In the case that a cylinder is not used up to the stroke end, and if it is stopped 5 mm or more before the stroke end, the cushioning effect will be weakened. In such a case, contact us.

How to order

General purpose type

The items in broken lines in the codes below need not to be entered, if unnecessary. Semi-standard specification

• Standard type 100H-2 2 LA 50 B B 100 - G A B - T K - J

• Switch set 100H-2R 2 LA 50 B B 100 - G A B AH 2 - T K - J

Double-Acting Single Rod
 100H-2 : Standard type
 100H-2R : Switch set

Double-Acting Double Rod
 100H-2D : Standard type
 100H-2RD : Switch set

1 Nitrile rubber
 2 Urethane rubber
 6 Hydrogenated nitrile rubber
 8 Combined seal

● For packing configuration, refer to the selection materials at the beginning of this catalogue.

Mounting type

Cylinder bore (mm)
 φ32 • φ40 • φ50 • φ63 • φ80 • φ100 • φ125

B Rod B

B with cushions on both ends
R with cushion on the rod side
H with cushion on the head side
N without cushion

None Rc thread
G G thread

Cylinder stroke (mm)

J Nylon tarpaulin
JN Chloroprene
JK Conex

K Long thread with lock nut
 ● For thread length, refer to the "Thread length with lock nut".

T T-end (rod end eye)
Y Y-end (rod end clevis)

Switch quantity (1, 2, to n)

Switch code
 Note) Select applicable switches out of the Switch List

① **Notes on order for switch sets**
 ● If a switch is unnecessary, enter the switch code ① and the switch quantity ② of 0.

Cushion valve position (A, B, C, D, 0)

Port position (A, B, C, D)

Cutting oil proof type

• Standard type 100HW-2 6 LA 50 B B 100 - G A B - T L

• Switch set 100HW-2R 6 LA 50 B B 100 - G A B 5 2 - T L

Double-Acting Single Rod
 100HW-2 : Standard type
 100HW-2R : Switch set

Hydrogenated nitrile rubber

Cylinder bore (mm)
 φ32 - φ80

Contact

5 WR505 (with 5 m cord)
7 WR505F (with 5 m cord/flexible tube attached)
6 WR515 (with 5 m/cord type)

No contact

2 WS215 (with 5 m cord)
4 WS215F (with 5 m cord/flexible tube attached)
3 WS225 (with 5 m/cord type)

Note) As for the descriptions on the types other than the above, refer to the descriptions on the general purpose type.

Switches

Kind	Switch symbol	Load voltage range	Load current range	Maximum open/close capacity	Protective circuit	Indicating lamp	Wiring method	Cord length	Applicable load device				
Contact	AF AX101	DC:5 - 30V AC:5 - 120V	DC:5 - 40mA AC:5 - 20mA	DC:1.5W AC:2VA	None	LED (Lights up in red during ON)	0.3 mm ² , 2-core, outer dia. 4 mm, rear wiring	1.5m	Small relay programmable controller				
	AG AX105							5m					
	AH AX111				1.5m								
	AJ AX115				5m								
	AE AX125	DC:30V or less AC:120V or less	DC:40mA or less AC:20mA or less	2VA	None	No	4-pin connector type, rear wiring	5m					
	AK AX11A	AC:5 - 120V	5 - 20mA					0.5m					
	AL AX11B	DC:5 - 30V	5 - 40mA	1.5W	Present	LED (Lights up in red during ON)	4-pin connector type, rear wiring	0.5m					
	AP AZ101	DC:5 - 30V AC:5 - 120V	DC:5 - 40mA AC:5 - 20mA	DC:1.5W AC:2VA				None		LED (Lights up in red during ON)	0.3 mm ² , 2-core, outer dia. 4 mm, upper wiring	1.5m	
	AR AZ105				5m								
	AS AZ111				1.5m								
	AT AZ115				5m								
	AN AZ125	DC:30V or less AC:120V or less	DC:40mA or less AC:20mA or less	2VA	None	No	4-pin connector type, upper wiring	5m					
	AU AZ11A	AC:5 - 120V	5 - 20mA					0.5m					
	AW AZ11B	DC:5 - 30V	5 - 40mA	1.5W	Present	LED (Lights up in red during ON)	4-pin connector type, upper wiring	0.5m					
	5 WR505	DC:5 - 50V AC:5 - 120V	DC:3 - 40mA AC:3 - 20mA	DC:1.5W AC:2VA				None		LED (Lights up in red during ON)	0.3 mm ² , 2-core, outer dia. 4 mm, rear wiring	5m	
	7 WR505F				5m								
6 WR515	5m												
No contact	BE AX201	DC:5 - 30V	5 - 40mA	—	Present	LED (Lights up in red during ON)	0.3 mm ² , 2-core, outer dia. 4 mm, rear wiring	1.5m	Small relay programmable controller				
	BF AX205							5m					
	CE AX211							1.5m					
	CF AX215					5m							
	CH AX21C					LED (2-lamp type, red/green)	4-pin connector type, rear wiring	0.5m					
	CJ AX21D							1m					
	BM AZ201							LED (Lights up in red during ON)		0.3 mm ² , 2-core, outer dia. 4 mm, upper wiring	1.5m		
	BN AZ205							5m					
	CM AZ211					LED (2-lamp type, red/green)	4-pin connector type, rear wiring	1.5m					
	CN AZ215					5m							
	2 WS215					DC:10 - 30V	6 - 70mA	—		Present	LED (Lights up in red during ON)	0.3 mm ² , 2-core, outer dia. 4 mm, rear wiring	5m
	4 WS215F												5m
	3 WS225												5m
No contact (CE conformed)	CT AX211CE	DC:5 - 30V	5 - 40mA	—	Present	LED (2-lamp type, red/green)	0.3 mm ² , 2-core, outer dia. 4 mm, rear wiring	1.5m	Small relay programmable controller				
	CU AX215CE							5m					
	CV AX21BCE							4-pin connector type, rear wiring		0.5m			
	CW AZ211CE							0.3 mm ² , 2-core, outer dia. 4 mm, upper wiring		1.5m			
	CX AZ215CE							5m					
	CY AZ21BCE							4-pin connector type, upper wiring		0.5m			

- Notes) ● For the switches without a protective circuit, be sure to provide the protective circuit (SK-100) with load devices when using induction load devices (relay, etc.).
 ● For the handling of switches, be sure to refer to the switch specifications in the end of this catalogue.
 ● For the 200 V AC type, contact us.
 ● We recommend AND UNIT (AU series) for multiple switches connected in series.

● General purpose type

AX type (Rear wiring)



AZ type (Upper wiring)

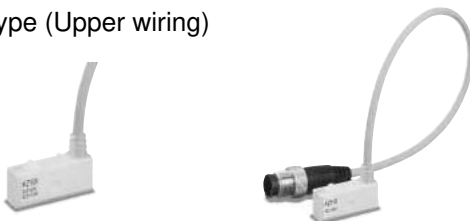

● Cutting oil proof type

WR · WS type switches

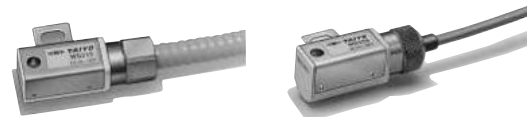

- For the switch code ①, pay attention to the points shown below when ordering the cutting oil proof type switches, WR and WS types.

- | | | |
|---|--------|--|
| 5 | WR505 | The switch and straight box connector (F-SB) are combined [the flexible tube (F-05: 4.8 m) is required]. |
| 2 | WR215 | |
| 7 | WR505F | The flexible tube (F-05: 4.8 m) is attached to the |
| 4 | WS215F | switch and straight box connector (F-SB). |

Mounting type Codes in the < > marks below are names called in ISO 10762.

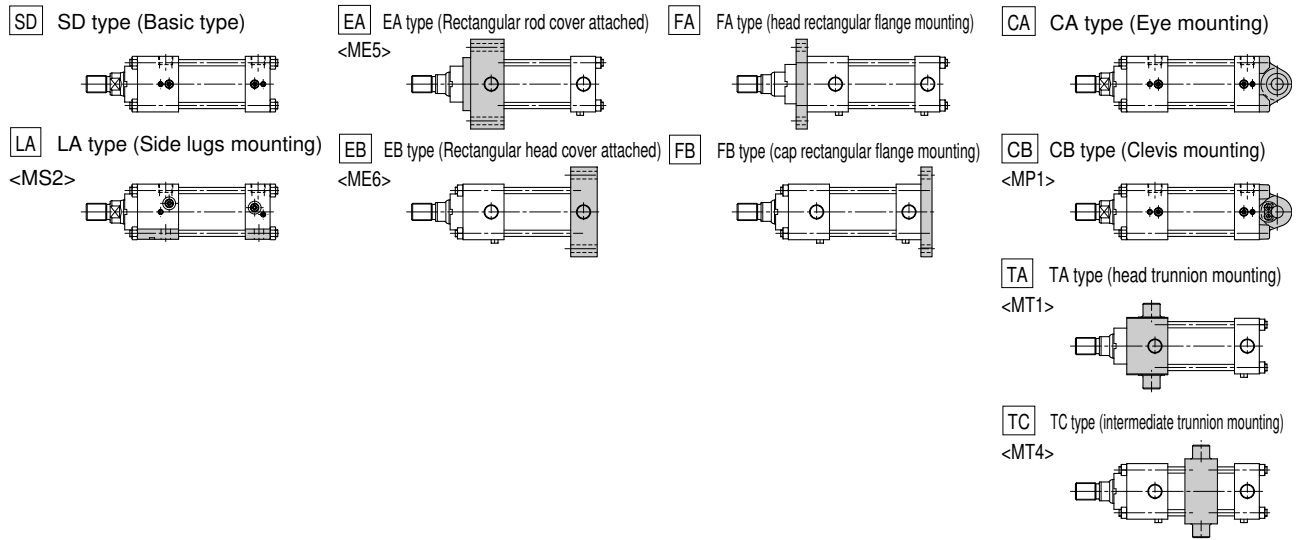

Note) SD, FA, and FB types are not included in ISO standards.

Adaptability of working oil to seal material

Packing material	Adaptable working oil				
	Petroleum-based fluid	Water-glycol fluid	Phosphate ester fluid	W/O Water in oil fluid	O/W Oil in water fluid
1 Nitrile rubber	○	○	×	○	○
2 Urethane rubber	◎	×	×	△	△
6 Hydrogenated nitrile rubber	○	◎	×	◎	◎
8 Combined seal	○	○	×	○	○

- The ◎ and ○-marked items are applicable, while the △-marked items are inapplicable.
- For the △-marked items, contact us before usage.
- The ◎-marked items are the recommended packing materials in the case of giving the first priority to wear resistance.
- For the working temperature range, refer to the selection materials.

Cutting oil proof type/Adaptability of seal materials to cutting oil

Packing material	Nonaqueous cutting oil		Aqueous cutting oil
	Type 1	Type 2	
6 Hydrogenated nitrile rubber	○	×	○

○: Applicable ×: Inapplicable

For the working temperature range of packing materials, refer to the selection materials in the beginning of this catalogue.

Seal structures and selection guidelines

Packing code		1	2	6	8
Name of type		Nitrile rubber type	Urethane rubber type	Hydrogenated nitrile rubber type	Combined seal type
Packing structure	Piston packing				
	Rod packing and wiper ring				
	Fixed section (including O-ring)	Nitrile rubber	Nitrile rubber	Hydrogenated nitrile rubber	Nitrile rubber

Switch mounting minimum allowable stroke

Unit : mm

Mounting style	Types other than TC type		TC type	
	AX type	WR • WS type	AX type	WR • WS type
φ32	30 (40)	55 (75)	115	170
φ40	30	55	115	170
φ50	30	55	125	175
φ63	30	55	130	180
φ80	30	55	140	190
φ100	25	50	150	200
φ125	20	50	160	210

- Figures in the parentheses on the line of 32 mm bore indicate the minimum strokes when the rod side detector switch and the head side detector switch are mounted on the same surface.

- Notes)
- The minimum stroke is identical whether only one switch (one-side stroke end detector) or two switches (double end detector) mounted.
 - For the TC type, the figures are applicable when the TC fitting is in the center, and the switch can be installed to both the rod side and the head side.

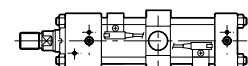

★ **Port position and cushion needle position**

- Standard type: With both end cushions
Standard port position, cushion valve position

Mounting style	Order symbol		Rod cover		Head cover	
	Port position	Valve position	Port position	Valve position	Port position	Valve position
SD · LA · CA · CB · FA · FB · TC	A (B · C · D)	B (C · D · A)	A (B · C · D)	B (C · D · A)	A (B · C · D)	B (C · D · A)
EB	A	B	A	B	A	C
EA · TA	A	C	A	C	A	B

- The symbols (A) shown in the table above indicate the standard port positions of types other than EA, EB, and TA, and symbols (B) indicate the standard cushion valve positions. When changing any position, write down symbols shown in dimensional drawings.

(Example)

100H-2R 2CA50BB100- B A AH2

Port position (A, B, C, D)

Cushion valve position (A, B, C, D, 0)

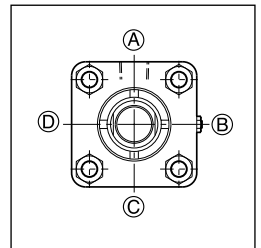

- **Specification of change in positions of head side port and cushion valve**

(Example)

100H-2 2CA50BB100-AB-X PPC

Rod side port and cushion valve position

Head side port and cushion position change specification symbol

Position specification: PC-BA

Head side port and cushion valve position

- Order symbols and port and cushion valve positions shown above are applicable to the EA, EB, and TA types. When changing any position, specify the position on the rod side or the head side.
As for the TA type rod cover, neither port nor cushion valve can be provided on the (B) or (D) side.
As for the EA type rod cover, cushion valves cannot be provided on the (B) or (D) side.
As for the EB type head cover, cushion valves cannot be provided on the (B) or (D) side.
- If the cylinder has no cushion, cushion valve position is indicated as "0".
- If the ports are located on the (B) or (D) side of the LA type cylinder and general piping joints are used, they may interfere with the cylinder mounting bolts.
- Air vents are located on the same side as that the cushion valves are installed.
If the cylinder has no cushion, they are located on the (B) side ((C) side, in the case of the EA or TA type rod cover).

★ **Port G thread (BSPP) type**

- **As for the port G thread type, add "G" ahead of the port position symbol.**

(Example)

100H-2R 2CA50BB100 - G A B

Port G thread type

Port position

Cushion valve position

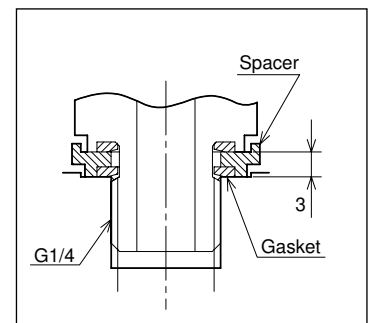

- Spacers for the rod side ports are provided for the 100H-2 with 32 mm bore. Be sure to use them for piping.
(If no spacer is attached to it, the joint may interfere with the parts in the cylinder.)

★ Notes on order of cylinder with lock nut

- The rod end thread length (A) must be longer when a lock nut **K** is attached to the rod end.

(Example)

100H-2R 2LA50BB200- ABAH2 -K

Long thread with lock nut

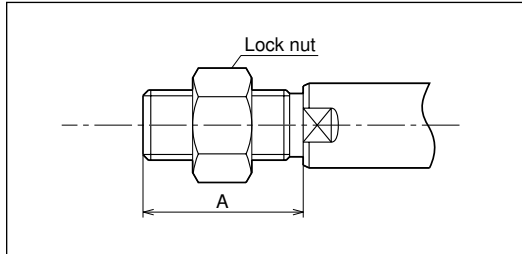

A without lock nut

A=28



A of long thread
with lock nut

A=40

Note) When a lock nut is attached to the rod end, length "A" shown in the figure above must be the same as that of the long thread with lock nut type or longer. For details, refer to "Thread length with lock nut".

★ Delivery of rod end attachment (T-end and Y-end)

Delivery specifications of the cylinder with lock nut and rod end attachment differ from those of the cylinder with rod end attachment only (without lock nut). For details, refer to the dimensional drawing of rod end attachment.

★ Semi-standard fabrication range

- Change in piston rod end
(Size symbol: WF (W), A, KK)
- Plated cylinder tube
(Hard chrome plated 2/100 mm)
- With boots

Weight table

Unit: kg

Bore mm	Basic weight (SD type)		Additional weight per 1 mm stroke		Mounting accessories weight										Rod end attachment weight		
	Single rod type	Double rod type	Single rod type	Double rod type	LA	EA	EB	FA	FB	CA	CB	TA	TC	Rod end eye (T-end)	Rod end clevis (Y-end)	Lock nut	
φ32	1.31	1.73	0.0062	0.0082	0.26	—	—	0.32	0.28	0.15	0.19	0.04	0.16	0.31	0.38	0.03	
φ40	1.96	2.50	0.0062	0.0092	0.24	0.43	0.43	0.45	0.37	0.22	0.29	0.06	0.56	0.38	0.54	0.03	
φ50	3.18	4.06	0.0103	0.0151	0.25	0.64	0.62	0.75	0.68	0.31	0.36	0.11	0.97	0.50	0.62	0.05	
φ63	4.99	6.32	0.0144	0.0224	0.32	0.72	0.91	1.26	1.11	0.88	1.07	0.22	1.39	1.25	1.86	0.09	
φ80	8.65	11.24	0.0227	0.0351	0.68	1.26	1.33	2.16	1.86	1.22	1.40	0.49	2.66	1.66	2.08	0.13	
φ100	14.27	17.66	0.0362	0.0554	1.13	1.31	1.99	3.15	2.81	2.15	2.65	0.82	3.85	2.98	3.98	0.23	
φ125	22.91	28.22	0.0547	0.0848	1.40	1.51	2.86	5.53	4.98	4.88	6.09	1.30	6.97	6.78	9.25	0.31	

Switch additional weight

Unit: kg

Switch Bore (mm)	AX type			WR · WS type
	Cord length 1.5 m	Cord length 5 m	Connector type	
φ32 - φ80	0.05	0.13	0.04	0.5
φ100 - φ125	0.07	0.15	0.06	0.5

Calculation formula cylinder weight (kg) = basic weight + (cylinder stroke mm × additional weight per 1 mm stroke) + mounting accessories weight + rod end attachment weight + (switch additional weight × switch quantity)

Calculation example 100H-2R, bore φ80, cylinder stroke 200 mm, LA type, 2 pcs. of AX215
 $8.65 + (0.0227 \times 200) + 0.68 + (0.13 \times 2) = 14.13$ kg

SD

100H-2 2 SD Bore B B Stroke - A B

Port G thread (BSPP) type

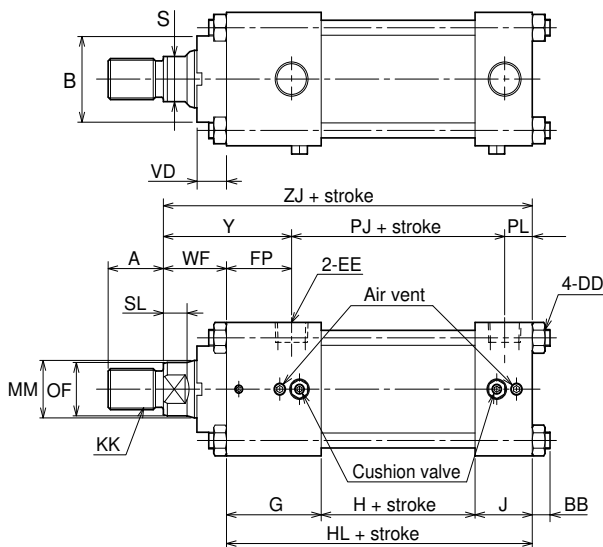
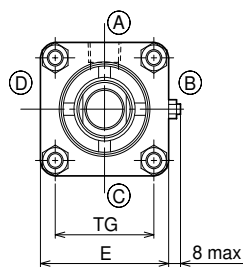
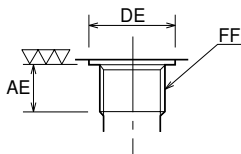

- Positions of the cushion needles and air vents depend on the cylinder bore.
- Rod end thread length (A) must be longer when a lock nut is attached to the rod end. Refer to "Rod end attachment/Rod end thread length with lock nut".
- For the use of the SD type, be sure to refer to the "Precautions for use, 4. Mounting" in the beginning of this catalogue.
- When you want to change the length of the projected rod, specify the "WF".

Double-acting double rod

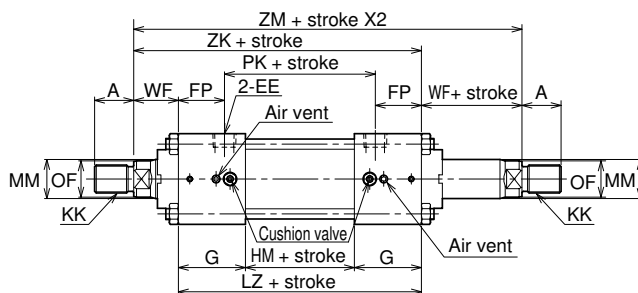

- Distance between the covers of the double rod type cylinder is longer than that of the single rod type cylinder by 10 mm.

With boots

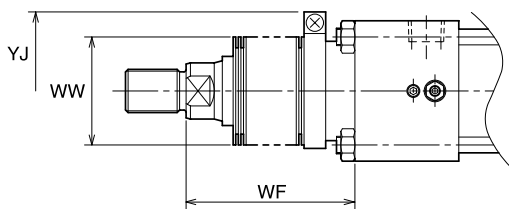

	Standard	Semi-standard	
Material	Nylon tarpaulin	Chloroprene	Conex
Resistible temperature	80°C	130°C	200°C

- Notes)
- Remember that the resistible temperatures shown in the table above are for the boots, not for the cylinder.
 - Conex is the registered trademark of Teijin Ltd.
 - The boots have been mounted at our factory prior to delivery.

WF

Nylon tarpaulin Chloroprene	φ32·φ40	1/3	Stroke+X
	φ50	1/3.5	Stroke+X
	φ63 - φ100	1/4	Stroke+X
	φ125	1/5	Stroke+X
Conex	φ32	1/2	Stroke+X
	φ40·φ50	1/2.5	Stroke+X
	φ63 - φ100	1/3	Stroke+X
	φ125	1/3.5	Stroke+X

- When the calculated WF has decimals, raise them to the next whole number.

Dimensional table

Symbol Bore	A	B		KK	MM	OF	S	SL	VD
		Standard type	Cutting oil proof type						
φ32	18	φ30f9	φ34f9	M14 X1.5	φ18	φ17	14	10	10
φ40	22	φ34f9	φ40f9	M16 X1.5	φ22	φ21	17	9	12
φ50	28	φ42f9	φ46f9	M20 X1.5	φ28	φ26	22	11	15
φ63	36	φ50f9	φ55f9	M27 X2	φ36	φ34	30	14	15
φ80	45	φ60f9	φ65f9	M33 X2	φ45	φ43	38	17	8
φ100	56	φ72f9	—	M42 X2	φ56	φ54	50	21	16
φ125	63	φ88f9	—	M48 X2	φ70	φ68	60	24	13

Symbol Bore	AE	BB	DD	DE	E	EE	FF	FP	G	H	HL
φ32	12 Note)	7	M6 X1	φ21.5	□45	Rc1/4	G1/4	35	49	28	103
φ40	12	7	M6 X1	φ25.5	□52	Rc3/8	G3/8	33	48	28	105
φ50	12	9	M8 X1	φ25.5	□65	Rc3/8	G3/8	33	48	28	105
φ63	14	9	M8 X1	φ30 or more	□76	Rc1/2	G1/2	35	53	30	117
φ80	14	11	M10 X1.25	φ30 or more	□94	Rc1/2	G1/2	42	62	34	131
φ100	16	14	M14 X1.5	φ36.9 or more	□114	Rc3/4	G3/4	38	61	40	143
φ125	16	16	M16 X1.5	φ36.9 or more	□140	Rc3/4	G3/4	39	62	47	151

Symbol Bore	HM	J	LZ	PJ	PK	PL	TG	WF	Y	ZJ	ZK	ZM
φ32	38	26	136	56	66	12	33.2	25	60	128	161	186
φ40	38	29	134	58	68	14	40	25	58	130	159	184
φ50	38	29	134	58	68	14	50	32	65	137	166	198
φ63	40	34	146	66	76	16	58	34	69	151	180	214
φ80	44	35	168	74	84	15	75	35	77	166	203	238
φ100	50	42	172	86	96	19	90	41	79	184	213	254
φ125	57	42	181	93	103	19	112	41	80	192	222	263

Notes) ● For the cylinder with 32 mm bore and the G thread port, the thread length adjuster spacer is installed on the rod side.

● Allowance of MM is f8.

With boots

Bore Symbol	φ32	φ40	φ50	φ63	φ80	φ100	φ125
WW	φ40	φ50	φ50	φ71	φ80	φ100	φ100
X	56	56	58	71	73	75	89
YJ	φ65	φ70	φ75	φ83	φ93	φ105	φ120

LA

100H-2 2 LA Bore B B Stroke - A B

Port G thread (BSPP) type

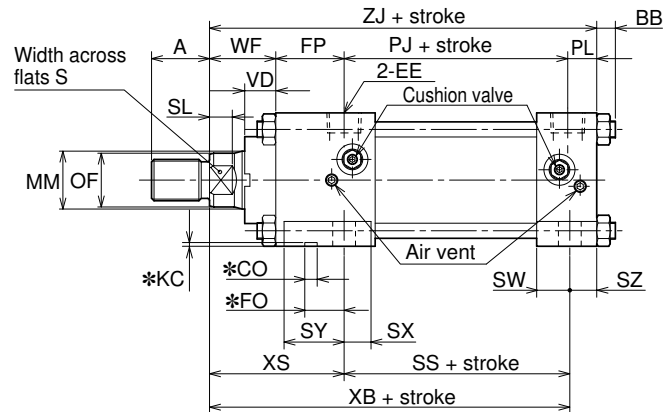
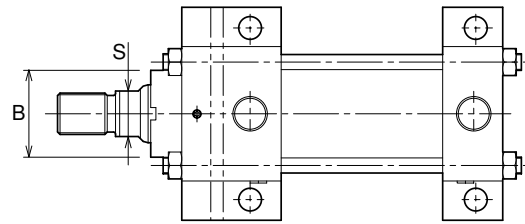
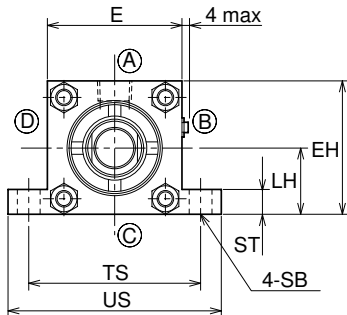
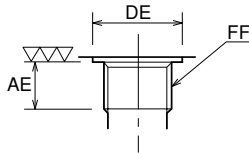

- Positions of the cushion needles and air vents depend on the cylinder bore.
- Rod end thread length (A) must be longer when a lock nut is attached to the rod end. Refer to "Rod end attachment".
- Notes on mounting bolts
Use bolts with hexagonal hole as the mounting bolts for cylinders other than the cylinder with 32 mm bore.
If hexagonal bolts are used, bolt heads may interfere with the cover or spot facing, causing failure in mounting.
- The CO, FO, and KC are key groove (optional) dimensions.
- When you want to change the length of the projected rod, specify the "WF".

Double-acting double rod (Rod B)

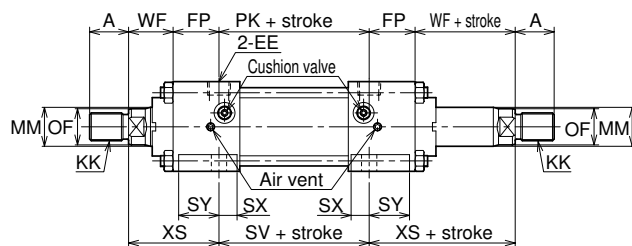

- Distance between the covers of the double rod type cylinder is longer than that of the single rod type cylinder by 10 mm.

With boots

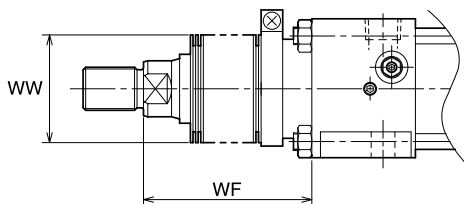

	Standard	Semi-standard	
Material	Nylon tarpaulin	Chloroprene	Conex
Resistible temperature	80°C	130°C	200°C

- Notes)
- Remember that the resistible temperatures shown in the table above are for the boots, not for the cylinder.
 - Conex is the registered trademark of Teijin Ltd.
 - The boots have been mounted at our factory prior to delivery.

WF

Nylon tarpaulin	$\left(\begin{array}{l} \phi 32 \cdot \phi 40 \\ \phi 50 \\ \phi 63 - \phi 100 \\ \phi 125 \end{array} \right)$	$\left(\begin{array}{l} 1/3 \\ 1/3.5 \\ 1/4 \\ 1/5 \end{array} \right)$	$\left(\begin{array}{l} \text{Stroke}+X \\ \text{Stroke}+X \\ \text{Stroke}+X \\ \text{Stroke}+X \end{array} \right)$
Chloroprene			
Conex			
	$\left(\begin{array}{l} \phi 32 \\ \phi 40 \cdot \phi 50 \\ \phi 63 - \phi 100 \\ \phi 125 \end{array} \right)$	$\left(\begin{array}{l} 1/2 \\ 1/2.5 \\ 1/3 \\ 1/3.5 \end{array} \right)$	$\left(\begin{array}{l} \text{Stroke}+X \\ \text{Stroke}+X \\ \text{Stroke}+X \\ \text{Stroke}+X \end{array} \right)$

- When the calculated WF has decimals, raise them to the next whole number.

● Notes on LA type with ports on lateral side (B) or (D) side

- The port G thread type is not the standard type. (Position on the (A) or (C) side is the same as that of the standard type.)
- Positions of the ports are deviated from the cylinder center by the distance LE.
- Take into consideration the interference of the piping and joint with the mounting bolts (including handling of tightening tools), referring to the table on the right.
- When the cylinder bore is 32 mm, mounting with hexagonal bolts is recommended.
- When the cylinder bore is 40 mm or longer, hexagonal bolts cannot be used (because the head of a hexagonal bolt may interfere with the cover or spot facing). Thus, in such a case, use bolts with hexagonal hole, and mount the cylinder by tightening nuts on the back of the mounting plate (refer to the drawing on the right side).

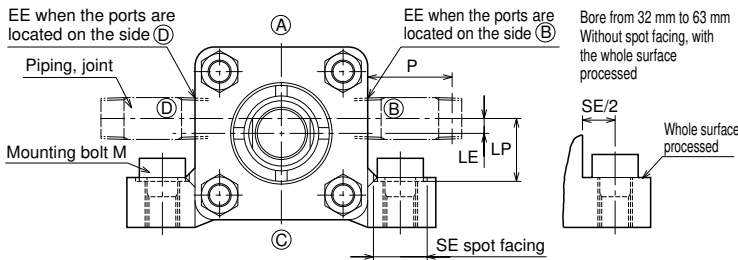

Symbol Bore	Port EE	LE	LP	Mounting bolt M	Spot facing dia. SE	P Note1
φ32	1/4	5.5	15	8	18	20
φ40	3/8	6.5	20	10	18	20
φ50	3/8	10	30	10	18	20
φ63	1/2	11	37	10	19	20
φ80	1/2	14	43.5	12	24	27
φ100	3/4	16	48	16	28	33
φ125	3/4	20	58.5	20	32	38

Note1. When determining the length P, interference of joints with mounting bolts must be taken into consideration.

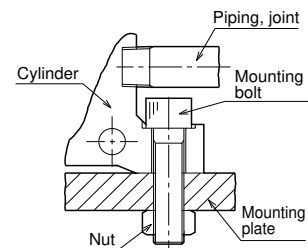

Dimensional table

Symbol Bore	A	B		KK	MM	OF	S	SL	VD
		Standard type	Cutting oil proof type						
φ32	18	φ30f9	φ34f9	M14 X1.5	φ18	φ17	14	10	10
φ40	22	φ34f9	φ40f9	M16 X1.5	φ22	φ21	17	9	12
φ50	28	φ42f9	φ46f9	M20 X1.5	φ28	φ26	22	11	15
φ63	36	φ50f9	φ55f9	M27 X2	φ36	φ34	30	14	15
φ80	45	φ60f9	φ65f9	M33 X2	φ45	φ43	38	17	8
φ100	56	φ72f9	—	M42 X2	φ56	φ54	50	21	16
φ125	63	φ88f9	—	M48 X2	φ70	φ68	60	24	13

Symbol Bore	AE	BB	DE	E	EE	EH	FF	FP	LH	PJ	PK	PL	SB	SS	ST	SV	SW	SX	SY	SZ	TS	US	WF
φ32	12 (Note)	7	φ21.5	45	Rc1/4	44.5	G1/4	35	22h10	56	66	12	φ9	73	12.5	96	16	29	20	10	63	84	25
φ40	12	7	φ25.5	52	Rc3/8	51.5	G3/8	33	25.5h10	58	68	14	φ11	59	12	68	16	15	33	13	70	90	25
φ50	12	9	φ25.5	65	Rc3/8	64.5	G3/8	33	32h10	58	68	14	φ11	59	12	68	16	15	33	13	83	103	32
φ63	14	9	φ30 or more	76	Rc1/2	76	G1/2	35	38h10	66	76	16	φ11	68	12	78	19	19	34	15	95	115	34
φ80	14	11	φ30 or more	94	Rc1/2	94.5	G1/2	42	47.5h10	74	84	15	φ14	74	18	84	20	17	39	13	121	147	35
φ100	16	14	φ36.9 or more	114	Rc3/4	114	G3/4	38	57h10	86	96	19	φ18	86	25	96	23	20	35	16	145	179	41
φ125	16	16	φ36.9 or more	140	Rc3/4	139.5	G3/4	39	69.5h10	93	103	19	φ22	95	31	105	24	21	35	17	175	216	41

Key groove (optional)

Symbol Bore	XB	XS	ZJ	CO	FO	KC
φ32	118	45	128	6N9	14	1.8 +0.3/0
φ40	117	58	130	6N9	18	1.8 +0.3/0
φ50	124	65	137	6N9	19	1.8 +0.3/0
φ63	136	68	151	12N9	21	3.3 +0.3/0
φ80	151	77	166	14N9	30	3.8 +0.3/0
φ100	165	79	184	14N9	30	3.8 +0.3/0
φ125	174	79	192	14N9	30	3.8 +0.3/0

Notes) ● For the cylinder with 32 mm bore and the G thread port, the thread length adjuster spacer is installed on the rod side.

- Allowance of MM is f8.

With boots

Bore Symbol	φ32	φ40	φ50	φ63	φ80	φ100	φ125
WW	φ40	φ50	φ50	φ71	φ80	φ100	φ100
X	56	56	58	71	73	75	89

EA

100H-2 2 EA Bore B B Stroke - A C

Port G thread (BSPP) type

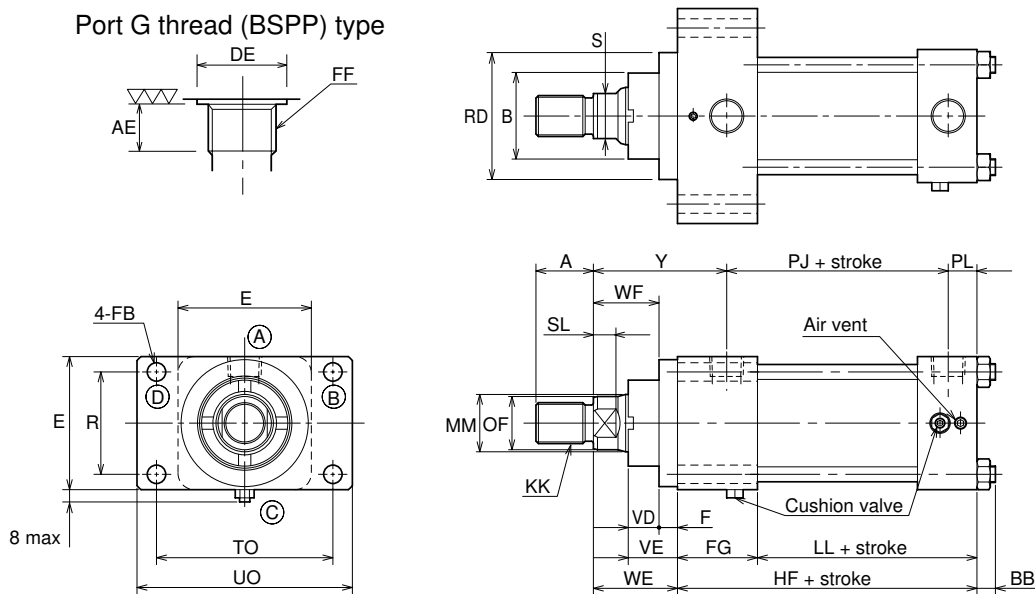

- Positions of the cushion needles and air vents depend on the cylinder bore.
- Rod end thread length (A) must be longer when a lock nut is attached to the rod end. Refer to "Rod end attachment/Rod end thread length with lock nut".
- If the mounting plate is located on the cylinder tube side of the switch set cylinder, take into consideration the interference of the switch with the mounting plate.
- When you want to change the length of the projected rod, specify the "WF".
- The symbols (A) and (C) shown in the figure above indicate the standard positions of port and cushion valve. (Rod side: (A) (C), Head side: (A) (B))
When changing any position, be sure to specify the port positions and cushion positions on the rod side or head side.

Double-acting double rod

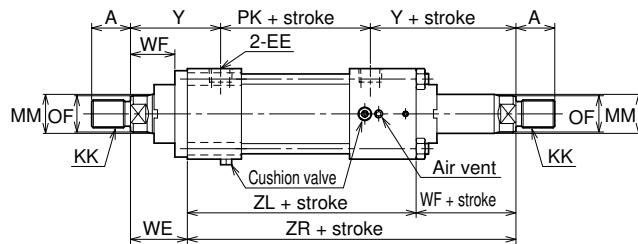

- Distance between the covers of the double rod type cylinder is longer than that of the single rod type cylinder by 10 mm.

With boots

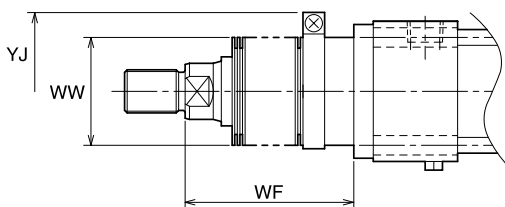

WF

Nylon tarpaulin	$\left(\begin{array}{l} \phi 40 \\ \phi 50 \end{array} \right)$	$\left(\begin{array}{l} 1/3 \\ 1/3.5 \end{array} \right)$	$\left(\begin{array}{l} \text{Stroke}+X \\ \text{Stroke}+X \end{array} \right)$
Chloroprene	$\left(\begin{array}{l} \phi 63 - \phi 100 \\ \phi 125 \end{array} \right)$	$\left(\begin{array}{l} 1/4 \\ 1/5 \end{array} \right)$	$\left(\begin{array}{l} \text{Stroke}+X \\ \text{Stroke}+X \end{array} \right)$
Conex	$\left(\begin{array}{l} \phi 40 - \phi 50 \\ \phi 63 - \phi 100 \\ \phi 125 \end{array} \right)$	$\left(\begin{array}{l} 1/2.5 \\ 1/3 \\ 1/3.5 \end{array} \right)$	$\left(\begin{array}{l} \text{Stroke}+X \\ \text{Stroke}+X \\ \text{Stroke}+X \end{array} \right)$

- When the calculated WF has decimals, raise them to the next whole number.

	Standard	Semi-standard	
Material	Nylon tarpaulin	Chloroprene	Conex
Resistible temperature	80°C	130°C	200°C

- Notes)
- Remember that the resistible temperatures shown in the table above are for the boots, not for the cylinder.
 - Conex is the registered trademark of Teijin Ltd.
 - The boots have been mounted at our factory prior to delivery.

Dimensional table

Symbol Bore	A	B		KK	MM	OF	RD	S	SL	VD	VE
		Standard type	Cutting oil proof type								
φ40	22	φ34f9	φ40f9	M16 X1.5	φ22	φ21	φ51f8	17	9	12	22
φ50	28	φ42f9	φ46f9	M20 X1.5	φ28	φ26	φ62f8	22	11	15	24
φ63	36	φ50f9	φ55f9	M27 X2	φ36	φ34	φ72f8	30	14	15	29
φ80	45	φ60f9	φ65f9	M33 X2	φ45	φ43	φ92f8	38	17	8	24
φ100	56	φ72f9	—	M42 X2	φ56	φ54	φ110f8	50	21	16	32
φ125	63	φ88f9	—	M48 X2	φ70	φ68	φ130f8	60	24	13	29

Symbol Bore	AE	BB	DE	E	EE	F	FB	FF	FG	HF	LL
φ50	12	9	φ25.5	□ 65	Rc3/8	9	φ9	G3/8	39	96	57
φ63	14	9	φ30 or more	□ 76	Rc1/2	14 (Note 1)	φ9	G1/2	39	103	64
φ80	14	11	φ30 or more	□ 94	Rc1/2	16	φ11	G1/2	46	115	69
φ100	16	14	φ36.9 or more	□ 114	Rc3/4	16	φ13.5	G3/4	45	127	82
φ125	16	16	φ36.9 or more	□ 140	Rc3/4	16	φ17.5	G3/4	46	135	89

Symbol Bore	PJ	PK	PL	R	TO	UO	WE	WF	Y	ZL	ZR
φ50	58	68	14	50	86	105	41	32	65	125	157
φ63	66	76	16	56	98	118	48	34	69	132	166
φ80	74	84	15	70	119	142	51	35	77	152	187
φ100	86	96	19	90	138	161	57	41	79	156	197
φ125	93	103	19	110	168	194	57	41	80	165	206

Note 1) ● According to the standard (JIS B8367-5), the maximum is 10.

- Allowance of MM is f8.

With boots

Symbol Bore	φ40	φ50	φ63	φ80	φ100	φ125
XX	56	58	71	73	75	89
YJ	φ70	φ75	φ83	φ93	φ105	φ120

EB

100H-2 2 EB Bore B B Stroke - A B

Port G thread (BSPP) type

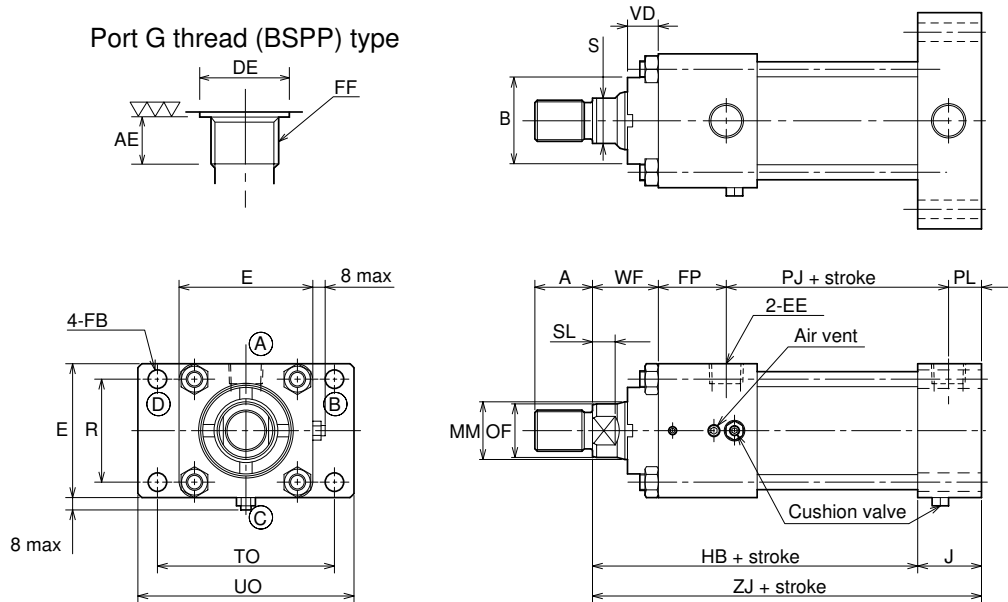

- Positions of the cushion needles and air vents depend on the cylinder bore.
- Rod end thread length (A) must be longer when a lock nut is attached to the rod end. Refer to "Rod end attachment/Rod end thread length with lock nut".
- If the mounting plate is located on the cylinder tube side of the switch set cylinder, take into consideration the interference of the switch with the mounting plate.
- When you want to change the length of the projected rod, specify the "WF".

- The symbols (A) and (C) shown in the figure above indicate the standard positions of port and cushion valve. (Rod side: (A) (C), Head side: (A) (B))
When changing any position, be sure to specify the port positions and cushion positions on the rod side or head side.

With boots

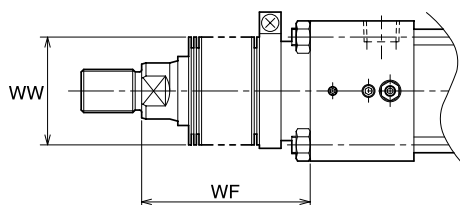

	Standard	Semi-standard	
Material	Nylon tarpaulin	Chloroprene	Conex
Resistible temperature	80°C	130°C	200°C

- Notes)
- Remember that the resistible temperatures shown in the table above are for the boots, not for the cylinder.
 - Conex is the registered trademark of Teijin Ltd.
 - The boots have been mounted at our factory prior to delivery.

WF

Nylon tarpaulin	$\left(\begin{array}{lll} \phi 40 & 1/3 & \text{Stroke}+X \\ \phi 50 & 1/3.5 & \text{Stroke}+X \\ \phi 63 - \phi 100 & 1/4 & \text{Stroke}+X \\ \phi 125 & 1/5 & \text{Stroke}+X \end{array} \right)$	
Chloroprene		
Conex		$\left(\begin{array}{lll} \phi 40 - \phi 50 & 1/2.5 & \text{Stroke}+X \\ \phi 63 - \phi 100 & 1/3 & \text{Stroke}+X \\ \phi 125 & 1/3.5 & \text{Stroke}+X \end{array} \right)$

- When the calculated WF has decimals, raise them to the next whole number.

Dimensional table

Symbol Bore	A	B		KK	MM	OF	S	SL	VD
		Standard type	Cutting oil proof type						
φ40	22	φ34f9	φ40f9	M16 X1.5	φ22	φ21	17	9	12
φ50	28	φ42f9	φ46f9	M20 X1.5	φ28	φ26	22	11	15
φ63	36	φ50f9	φ55f9	M27 X2	φ36	φ34	30	14	15
φ80	45	φ60f9	φ65f9	M33 X2	φ45	φ43	38	17	8
φ100	56	φ72f9	—	M42 X2	φ56	φ54	50	21	16
φ125	63	φ88f9	—	M48 X2	φ70	φ68	60	24	13

Symbol Bore	AE	DE	E	EE	FB	FF	FP	HB	J	PJ	PK
φ40	12	φ25.5	□52	Rc3/8	φ6.6	G3/8	33	101	31	58	68
φ50	12	φ25.5	□65	Rc3/8	φ9	G3/8	33	108	31	58	68
φ63	14	φ30 or more	□76	Rc1/2	φ9	G1/2	35	117	36	66	76
φ80	14	φ30 or more	□94	Rc1/2	φ11	G1/2	42	131	37	74	84
φ100	16	φ36.9 or more	□114	Rc3/4	φ13.5	G3/4	38	142	45	86	96
φ125	16	φ36.9 or more	□140	Rc3/4	φ17.5	G3/4	39	150	46	93	103

Symbol Bore	PL	R	TO	UO	WF	ZJ
φ40	16	40	70	86	25	132
φ50	16	50	86	105	32	139
φ63	18	56	98	118	34	153
φ80	17	70	119	142	35	168
φ100	22	90	138	161	41	187
φ125	23	110	168	194	41	196

● Allowance of MM is f8.

With boots

Bore Symbol	φ40	φ50	φ63	φ80	φ100	φ125
WW	φ50	φ50	φ71	φ80	φ100	φ100
X	56	58	71	73	75	89

FA

100H-2 2 FA Bore B B Stroke – A B

Port G thread (BSPP) type

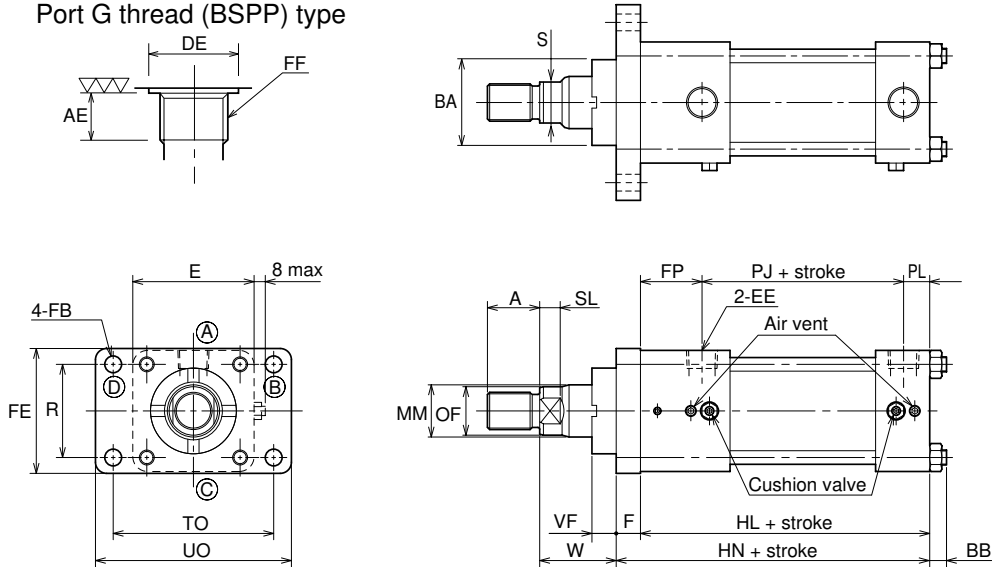

- Positions of the cushion needles and air vents depend on the cylinder bore.
- Rod end thread length (A) must be longer when a lock nut is attached to the rod end. Refer to "Rod end attachment/Rod end thread length with lock nut".
- When you want to change the length of the projected rod, specify the "W".

Double-acting double rod

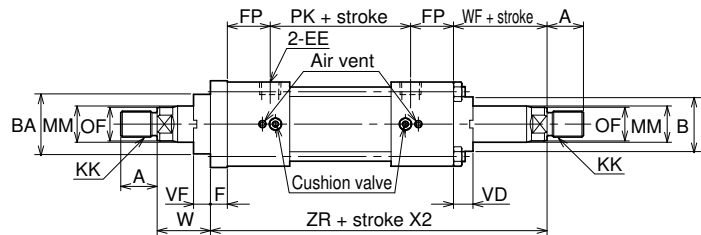

- Distance between the covers of the double rod type cylinder is longer than that of the single rod type cylinder by 10 mm.

With boots

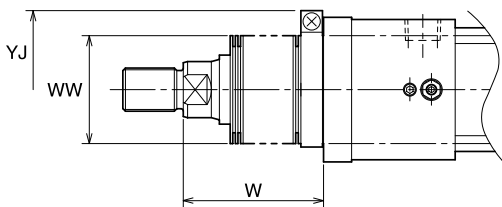

W

Nylon tarpaulin	$\phi 32 \cdot \phi 40$	1/3	Stroke+X
Chloroprene	$\phi 50$	1/3.5	Stroke+X
	$\phi 63 - \phi 100$	1/4	Stroke+X
	$\phi 125$	1/5	Stroke+X
Conex	$\phi 32$	1/2	Stroke+X
	$\phi 40 \cdot \phi 50$	1/2.5	Stroke+X
	$\phi 63 - \phi 100$	1/3	Stroke+X
	$\phi 125$	1/3.5	Stroke+X

- When the calculated W has decimals, raise them to the next whole number.

	Standard	Semi-standard	
Material	Nylon tarpaulin	Chloroprene	Conex
Resistible temperature	80°C	130°C	200°C

- Notes)
- Remember that the resistible temperatures shown in the table above are for the boots, not for the cylinder.
 - Conex is the registered trademark of Teijin Ltd.
 - The boots have been mounted at our factory prior to delivery.

Dimensional table

Symbol Bore	A	B		BA	KK	MM	OF	S	SL	VD	VF
		Standard type	Cutting oil proof type								
φ32	18	φ30f9	φ34f9	φ34f9	M14 X1.5	φ18	φ17	14	10	10	13
φ40	22	φ34f9	φ40f9	φ40f9	M16 X1.5	φ22	φ21	17	9	12	13
φ50	28	φ42f9	φ46f9	φ46f9	M20 X1.5	φ28	φ26	22	11	15	13
φ63	36	φ50f9	φ55f9	φ55f9	M27 X2	φ36	φ34	30	14	15	13
φ80	45	φ60f9	φ65f9	φ65f9	M33 X2	φ45	φ43	38	17	8	13
φ100	56	φ72f9	—	φ77f9	M42 X2	φ56	φ54	50	21	16	13
φ125	63	φ88f9	—	φ92f9	M48 X2	φ70	φ68	60	24	13	13

Symbol Bore	AE	BB	DE	E	EE	F	FB	FE	FF	FP	HL	HN
φ32	12 (Note 1)	7	φ21.5	□45	Rc1/4	11	φ6.6	47	G1/4	35	103	114
φ40	12	7	φ25.5	□52	Rc3/8	11	φ6.6	54	G3/8	33	105	116
φ50	12	9	φ25.5	□65	Rc3/8	13	φ9	67	G3/8	33	105	118
φ63	14	9	φ30 or more	□76	Rc1/2	16	φ9	78	G1/2	35	117	133
φ80	14	11	φ30 or more	□94	Rc1/2	18	φ11	96	G1/2	42	131	149
φ100	16	14	φ36.9 or more	□114	Rc3/4	20	φ13.5	116	G3/4	38	143	163
φ125	16	16	φ36.9 or more	□140	Rc3/4	24	φ17.5	142	G3/4	39	151	175

Symbol Bore	PJ	PK	PL	R	TO	UO	W	WF	ZR
φ32	56	66	12	33	58	70	35	25	172
φ40	58	68	14	40	70	86	35	25	170
φ50	58	68	14	50	86	105	41	32	179
φ63	66	76	16	56	98	118	48	34	196
φ80	74	84	15	70	119	143	51	35	221
φ100	86	96	19	90	138	162	57	41	233
φ125	93	103	19	110	168	194	57	41	246

Note 1) ● For the cylinder with 32 mm bore and the G thread port, the thread length adjuster spacer is installed on the rod side.

● Allowance of MM is f8.

With boots

Bore Symbol	φ32	φ40	φ50	φ63	φ80	φ100	φ125
WW	φ40	φ50	φ50	φ71	φ80	φ100	φ100
X	45	45	45	55	55	55	65
YJ	φ65	φ70	φ75	φ83	φ93	φ105	φ120

FB

100H-2 2 FB Bore B B Stroke – A B

Port G thread (BSPP) type

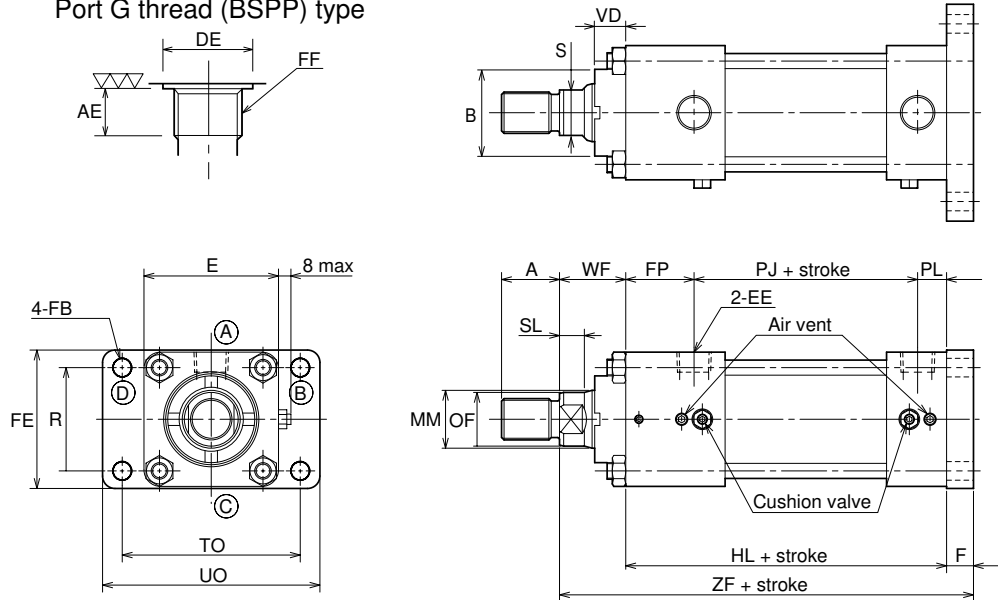

- Positions of the cushion needles and air vents depend on the cylinder bore.
- Rod end thread length (A) must be longer when a lock nut is attached to the rod end. Refer to "Rod end attachment/Rod end thread length with lock nut".
- When you want to change the length of the projected rod, specify the "WF".
- For the G thread type, the FB attachment may interfere with the joint when the joint is screwed into the head side port, depending on the joint type. Refer to the PL, and check the size of the joint to be used. Contact us if any interference occurs.

With boots

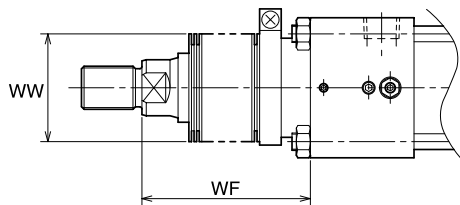

	Standard	Semi-standard	
Material	Nylon tarpaulin	Chloroprene	Conex
Resistible temperature	80°C	130°C	200°C

- Notes)
- Remember that the resistible temperatures shown in the table above are for the boots, not for the cylinder.
 - Conex is the registered trademark of Teijin Ltd.
 - The boots have been mounted at our factory prior to delivery.

WF

Nylon tarpaulin	$\phi 32 \cdot \phi 40$	1/3	Stroke+X
Chloroprene	$\phi 50$	1/3.5	Stroke+X
	$\phi 63 - \phi 100$	1/4	Stroke+X
	$\phi 125$	1/5	Stroke+X
Conex	$\phi 32$	1/2	Stroke+X
	$\phi 40 \cdot \phi 50$	1/2.5	Stroke+X
	$\phi 63 - \phi 100$	1/3	Stroke+X
	$\phi 125$	1/3.5	Stroke+X

- When the calculated WF has decimals, raise them to the next whole number.

Dimensional table

Symbol Bore	A	B		KK	MM	OF	S	SL	VD
		Standard type	Cutting oil proof type						
φ32	18	φ30f9	φ34f9	M14 X1.5	φ18	φ17	14	10	10
φ40	22	φ34f9	φ40f9	M16 X1.5	φ22	φ21	17	9	12
φ50	28	φ42f9	φ46f9	M20 X1.5	φ28	φ26	22	11	15
φ63	36	φ50f9	φ55f9	M27 X2	φ36	φ34	30	14	15
φ80	45	φ60f9	φ65f9	M33 X2	φ45	φ43	38	17	8
φ100	56	φ72f9	—	M42 X2	φ56	φ54	50	21	16
φ125	63	φ88f9	—	M48 X2	φ70	φ68	60	24	13

Symbol Bore	AE	DE	E	EE	F	FB	FE	FF	FP	HL	PJ
φ40	12	φ25.5	□ 52	Rc3/8	11	φ6.6	54	G3/8	33	105	58
φ50	12	φ25.5	□ 65	Rc3/8	13	φ9	67	G3/8	33	105	58
φ63	14	φ30 or more	□ 76	Rc1/2	16	φ9	78	G1/2	35	117	66
φ80	14	φ30 or more	□ 94	Rc1/2	18	φ11	96	G1/2	42	131	74
φ100	16	φ36.9 or more	□ 114	Rc3/4	20	φ13.5	116	G3/4	38	143	86
φ125	16	φ36.9 or more	□ 140	Rc3/4	24	φ17.5	142	G3/4	39	151	93

Symbol Bore	PK	PL	R	TO	UO	WF	ZF
φ40	68	14	40	70	86	25	141
φ50	68	14	50	86	105	32	150
φ63	76	16	56	98	118	34	167
φ80	84	15	70	119	143	35	184
φ100	96	19	90	138	162	41	204
φ125	103	19	110	168	194	41	216

Note 1) ● For the cylinder with 32 mm bore and the G thread port, the thread length adjuster spacer is installed on the rod side.

● Allowance of MM is f8.

With boots

Symbol Bore	φ32	φ40	φ50	φ63	φ80	φ100	φ125
X	56	56	58	71	73	75	89

CA

100H-2 | 2 | CA | Bore | B | B | Stroke | - | A | B

● Bore from 40mm to 100mm

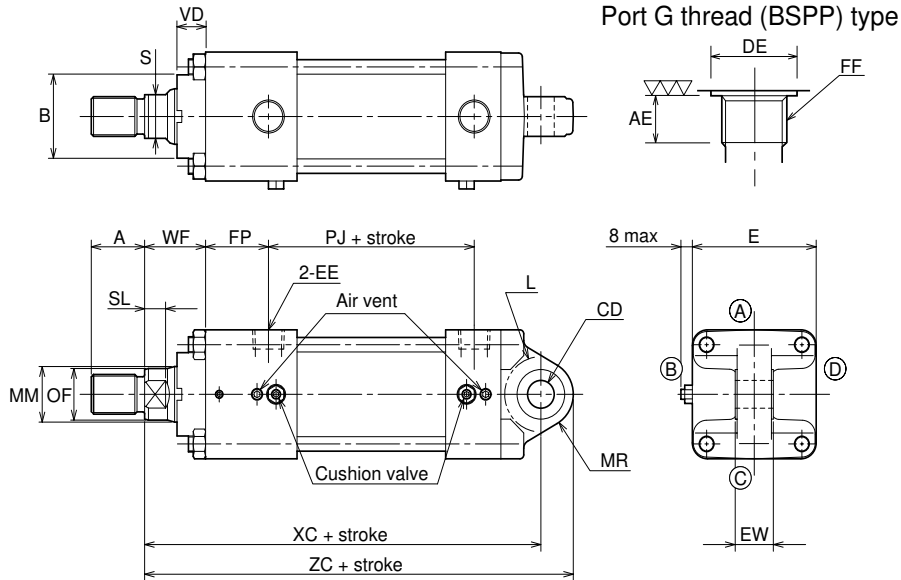

- Positions of the cushion needles and air vents depend on the cylinder bore.
- Rod end thread length (A) must be longer when a lock nut is attached to the rod end. Refer to "Rod end attachment/ Rod end thread length with lock nut".
- When you want to change the length of the projected rod, specify the "WF".

● Bore 32 mm, 125 mm

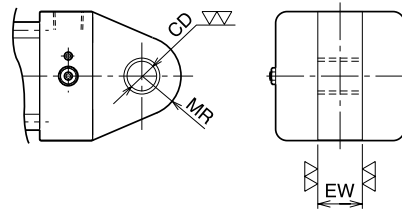

With boots

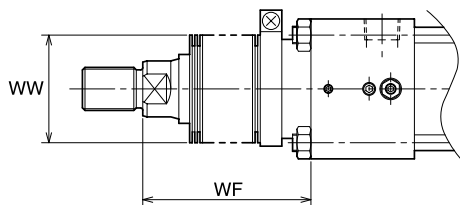

	Standard	Semi-standard	
Material	Nylon tarpaulin	Chloroprene	Conex
Resistible temperature	80°C	130°C	200°C

- Notes)
- Remember that the resistible temperatures shown in the table above are for the boots, not for the cylinder.
 - Conex is the registered trademark of Teijin Ltd.
 - The boots have been mounted at our factory prior to delivery.

WF

Nylon tarpaulin	$\phi 32 \cdot \phi 40$	1/3	Stroke+X
Chloroprene	$\phi 50$	1/3.5	Stroke+X
	$\phi 63 - \phi 100$	1/4	Stroke+X
	$\phi 125$	1/5	Stroke+X
Conex	$\phi 32$	1/2	Stroke+X
	$\phi 40 \cdot \phi 50$	1/2.5	Stroke+X
	$\phi 63 - \phi 100$	1/3	Stroke+X
	$\phi 125$	1/3.5	Stroke+X

- When the calculated WF has decimals, raise them to the next whole number.

Dimensional table

Symbol Bore	A	B		KK	MM	OF	S	SL	VD
		Standard type	Cutting oil proof type						
φ32	18	φ30f9	φ34f9	M14 X1.5	φ18	φ17	14	10	10
φ40	22	φ34f9	φ40f9	M16 X1.5	φ22	φ21	17	9	12
φ50	28	φ42f9	φ46f9	M20 X1.5	φ28	φ26	22	11	15
φ63	36	φ50f9	φ55f9	M27 X2	φ36	φ34	30	14	15
φ80	45	φ60f9	φ65f9	M33 X2	φ45	φ43	38	17	8
φ100	56	φ72f9	—	M42 X2	φ56	φ54	50	21	16
φ125	63	φ88f9	—	M48 X2	φ70	φ68	60	24	13

Symbol Bore	AE	CD	DE	E	EE	EW	FF	FP	L	MR	PJ	WF
φ32	12 Note)	φ12H9	φ21.5	□45	Rc1/4	16h14	G1/4	35	R19	R17	56	25
φ40	12	φ14H9	φ25.5	□52	Rc3/8	20h14	G3/8	33	R19	R17	58	25
φ50	12	φ14H9	φ25.5	□65	Rc3/8	20h14	G3/8	33	R19	R17	58	32
φ63	14	φ20H9	φ30 or more	□76	Rc1/2	30h14	G1/2	35	R32	R29	66	34
φ80	14	φ20H9	φ30 or more	□94	Rc1/2	30h14	G1/2	42	R32	R29	74	35
φ100	16	φ28H9	φ36.9 or more	□114	Rc3/4	40h14	G3/4	38	R39	R34	86	41
φ125	16	φ36H9	φ36.9 or more	□140	Rc3/4	50h14	G3/4	39	R54	R50	93	41

Symbol Bore	XC	ZC
φ32	147	164
φ40	151	168
φ50	158	175
φ63	185	214
φ80	200	229
φ100	226	260
φ125	250	300

- Notes) ● For the cylinder with 32 mm bore and the G thread port, the thread length adjuster spacer is installed on the rod side.
● Allowance of MM is f8.

With boots

Bore Symbol	φ32	φ40	φ50	φ63	φ80	φ100	φ125
WW	φ40	φ50	φ50	φ71	φ80	φ100	φ100
X	56	56	58	71	73	75	89

CB

100H-2 [2] CB Bore B [B] Stroke - [A] [B]

● Bore from 40mm to 125mm

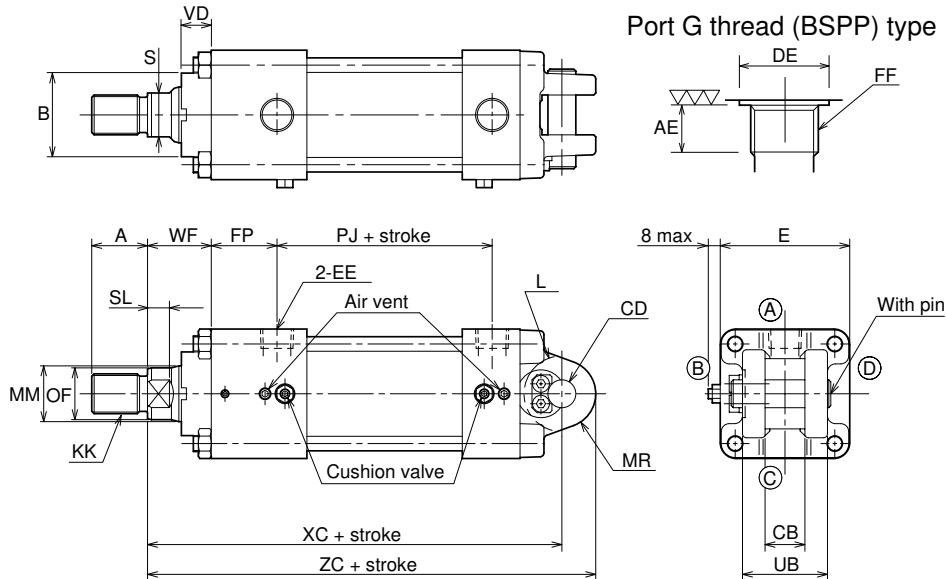

- Positions of the cushion needles and air vents depend on the cylinder bore.
- Rod end thread length (A) must be longer when a lock nut is attached to the rod end. Refer to "Rod end attachment/Rod end thread length with lock nut".
- When you want to change the length of the projected rod, specify the "WF".

● Bore 32 mm

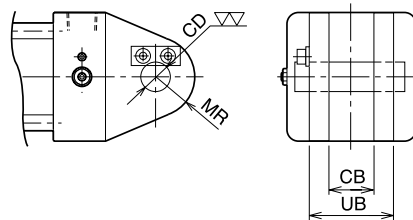

With boots

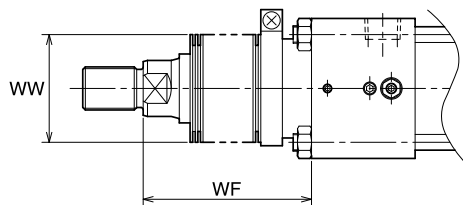

WF

Nylon tarpaulin	$\phi 32 \cdot \phi 40$	1/3	Stroke+X
Chloroprene	$\phi 50$	1/3.5	Stroke+X
	$\phi 63 - \phi 100$	1/4	Stroke+X
	$\phi 125$	1/5	Stroke+X
Conex	$\phi 32$	1/2	Stroke+X
	$\phi 40 \cdot \phi 50$	1/2.5	Stroke+X
	$\phi 63 - \phi 100$	1/3	Stroke+X
	$\phi 125$	1/3.5	Stroke+X

- When the calculated WF has decimals, raise them to the next whole number.

	Standard	Semi-standard	
Material	Nylon tarpaulin	Chloroprene	Conex
Resistible temperature	80°C	130°C	200°C

- Notes)
- Remember that the resistible temperatures shown in the table above are for the boots, not for the cylinder.
 - Conex is the registered trademark of Teijin Ltd.
 - The boots have been mounted at our factory prior to delivery.

Dimensional table

Symbol Bore	A	B		KK	MM	OF	S	SL	VD
		Standard type	Cutting oil proof type						
φ32	18	φ30f9	φ34f9	M14 X1.5	φ18	φ17	14	10	10
φ40	22	φ34f9	φ40f9	M16 X1.5	φ22	φ21	17	9	12
φ50	28	φ42f9	φ46f9	M20 X1.5	φ28	φ26	22	11	15
φ63	36	φ50f9	φ55f9	M27 X2	φ36	φ34	30	14	15
φ80	45	φ60f9	φ65f9	M33 X2	φ45	φ43	38	17	8
φ100	56	φ72f9	—	M42 X2	φ56	φ54	50	21	16
φ125	63	φ88f9	—	M48 X2	φ70	φ68	60	24	13

Symbol Bore	AE	CB	CD	DE	E	EE	FF	FP	L	MR	PJ
φ40	12	20A16	φ14 H9/f8	φ25.5	□ 52	Rc3/8	G3/8	33	R19	R17	58
φ50	12	20A16	φ14 H9/f8	φ25.5	□ 65	Rc3/8	G3/8	33	R19	R17	58
φ63	14	30A16	φ20 H9/f8	φ30 or more	□ 76	Rc1/2	G1/2	35	R32	R29	66
φ80	14	30A16	φ20 H9/f8	φ30 or more	□ 94	Rc1/2	G1/2	42	R32	R29	74
φ100	16	40A16	φ28 H9/f8	φ36.9 or more	□ 114	Rc3/4	G3/4	38	R39	R34	86
φ125	16	50A16	φ36 H9/f8	φ36.9 or more	□ 140	Rc3/4	G3/4	39	R54	R50	93

Symbol Bore	UB	WF	XC	ZC
φ40	43	25	151	168
φ50	43	32	158	175
φ63	65	34	185	214
φ80	65	35	200	229
φ100	83	41	226	260
φ125	103	41	250	300

- Note 1) ● For the cylinder with 32 mm bore and the G thread port, the thread length adjuster spacer is installed on the rod side.
● Allowance of MM is f8.

With boots

Symbol Bore	φ32	φ40	φ50	φ63	φ80	φ100	φ125
X	56	56	58	71	73	75	89

TA

100H-2 2 TA Bore B B Stroke - A C

Port G thread (BSPP) type

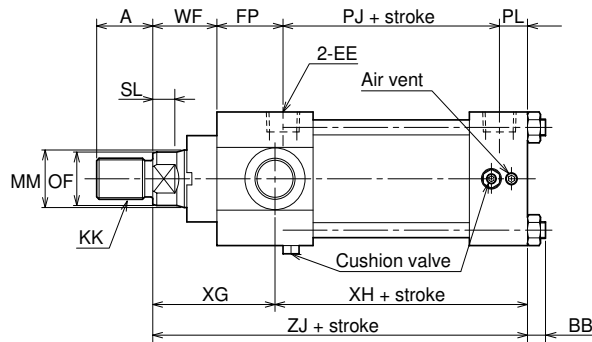
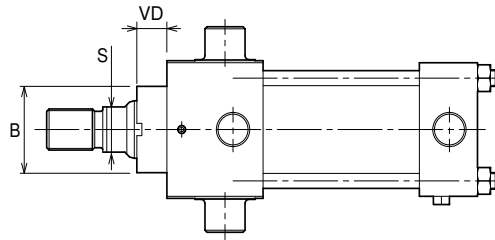
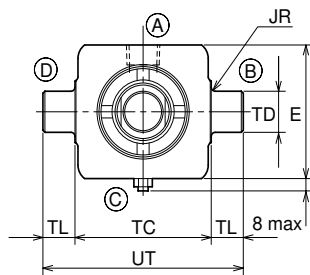
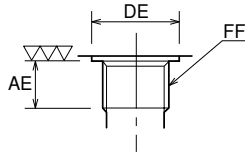

- Positions of the cushion needles and air vents depend on the cylinder bore.
- Rod end thread length (A) must be longer when a lock nut is attached to the rod end. Refer to "Rod end attachment/Rod end thread length with lock nut".
- If the stroke is short, pay attention to prevent the cushion valve from interfering with the mounting bracket.
- When you want to change the length of the projected rod, specify the "WF".

Double-acting double rod

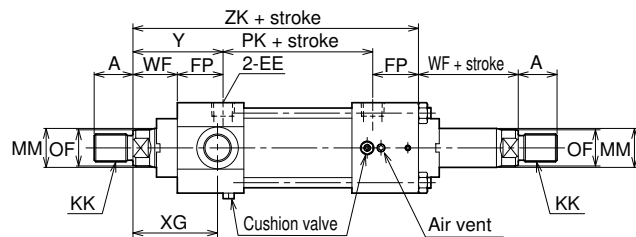

- Distance between the covers of the double rod type cylinder is longer than that of the single rod type cylinder by 10 mm.

With boots

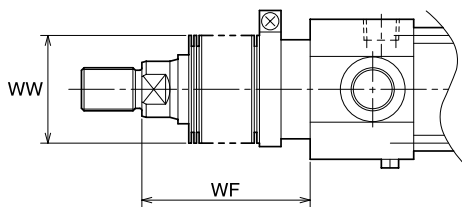

	Standard	Semi-standard	
Material	Nylon tarpaulin	Chloroprene	Conex
Resistible temperature	80°C	130°C	200°C

- Notes)
- Remember that the resistible temperatures shown in the table above are for the boots, not for the cylinder.
 - Conex is the registered trademark of Teijin Ltd.
 - The boots have been mounted at our factory prior to delivery.

WF

Nylon tarpaulin	$\phi 32 \cdot \phi 40$	1/3	Stroke+X
Chloroprene	$\phi 50$	1/3.5	Stroke+X
	$\phi 63 - \phi 100$	1/4	Stroke+X
	$\phi 125$	1/5	Stroke+X
Conex	$\phi 32$	1/2	Stroke+X
	$\phi 40 \cdot \phi 50$	1/2.5	Stroke+X
	$\phi 63 - \phi 100$	1/3	Stroke+X
	$\phi 125$	1/3.5	Stroke+X

- When the calculated WF has decimals, raise them to the next whole number.

Dimensional table

Symbol Bore	A	B		KK	MM	OF	S	SL	VD
		Standard type	Cutting oil proof type						
φ32	18	φ30f9	φ34f9	M14 X1.5	φ18	φ17	14	10	10
φ40	22	φ34f9	φ40f9	M16 X1.5	φ22	φ21	17	9	12
φ50	28	φ42f9	φ46f9	M20 X1.5	φ28	φ26	22	11	15
φ63	36	φ50f9	φ55f9	M27 X2	φ36	φ34	30	14	15
φ80	45	φ60f9	φ65f9	M33 X2	φ45	φ43	38	17	8
φ100	56	φ72f9	—	M42 X2	φ56	φ54	50	21	16
φ125	63	φ88f9	—	M48 X2	φ70	φ68	60	24	13

Symbol Bore	AE	BB	DE	E	EE	FF	FP	JR	PJ	PK	PL	TC
φ40	12	7	φ25.5	□ 52	Rc3/8	G3/8	33	R2	58	68	14	55h14
φ50	12	9	φ25.5	□ 65	Rc3/8	G3/8	33	R2	58	68	14	68h14
φ63	14	9	φ30 or more	□ 76	Rc1/2	G1/2	35	R2.5	66	76	16	80h14
φ80	14	11	φ30 or more	□ 94	Rc1/2	G1/2	42	R2.5	74	84	15	100h14
φ100	16	14	φ36.9 or more	□ 114	Rc3/4	G3/4	38	R3	86	96	19	120h14
φ125	16	16	φ36.9 or more	□ 140	Rc3/4	G3/4	39	R3	93	103	19	145h14

Symbol Bore	TD	TL	UT	WF	XG	XH	ZJ	ZK
φ40	φ16f8	12	79	25	54	76	130	159
φ50	φ20f8	16	100	32	61	76	137	166
φ63	φ25f8	20	120	34	67	84	151	180
φ80	φ32f8	25	150	35	73	93	166	203
φ100	φ40f8	32	184	41	79	105	184	213
φ125	φ50f8	40	225	41	71	121	192	222

Note 1) ● For the cylinder with 32 mm bore and the G thread port, the thread length adjuster spacer is installed on the rod side.

- Allowance of MM is f8.

With boots

Symbol Bore	φ32	φ40	φ50	φ63	φ80	φ100	φ125
X	56	56	58	71	73	75	89

TC

100H-2 2 TC Bore B B Stroke - A B

Port G thread (BSPB) type

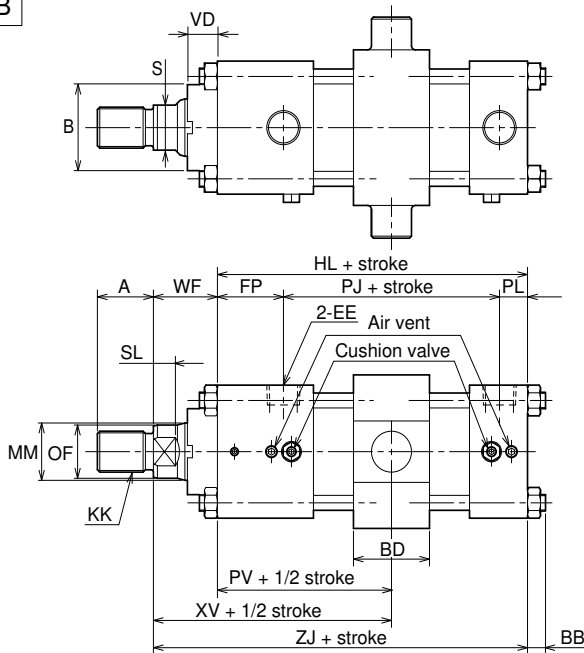
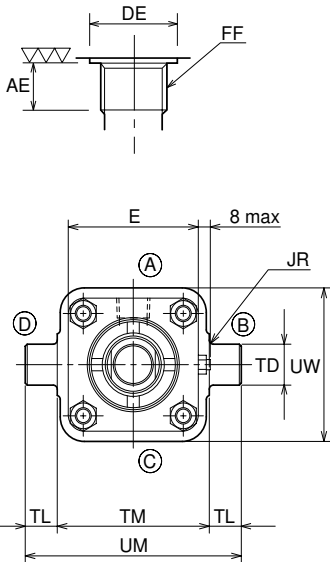

- Positions of the cushion needles and air vents depend on the cylinder bore.
- Rod end thread length (A) must be longer when a lock nut is attached to the rod end. Refer to "Rod end attachment/Rod end thread length with lock nut".
- If the stroke is short, pay attention to prevent the cushion valve from interfering with the mounting bracket.
- When you want to change the length of the projected rod, specify the "WF". ("WF" is necessary for specifying XV and XW.)
- The TC attachment must be normally positioned in the center. When changing the position, contact us.

Double-acting double rod

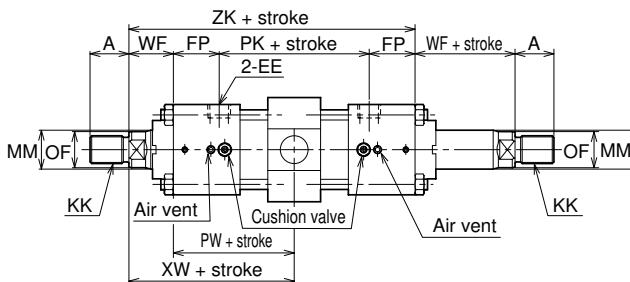

- Distance between the covers of the double rod type cylinder is longer than that of the single rod type cylinder by 10 mm.

Minimum stroke of TC type

Bore	φ32	φ40	φ50	φ63	φ80	φ100	φ125
Minimum stroke	10	50	50	50	100	100	100

Note) ● As for the minimum stroke with the switch set, refer to the page including the model codes.

With boots

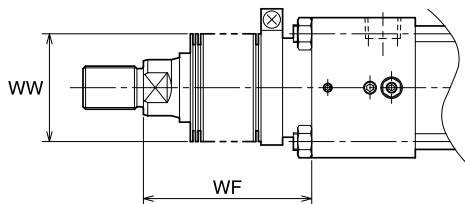

	Standard	Semi-standard	
Material	Nylon tarpaulin	Chloroprene	Conex
Resistible temperature	80°C	130°C	200°C

- Notes) ● Remember that the resistible temperatures shown in the table above are for the boots, not for the cylinder.
- Conex is the registered trademark of Teijin Ltd.
 - The boots have been mounted at our factory prior to delivery.

WF

Nylon tarpaulin	φ32-φ40	1/3	Stroke+X
Chloroprene	φ50	1/3.5	Stroke+X
	φ63 - φ100	1/4	Stroke+X
	φ125	1/5	Stroke+X

Conex	φ32	1/2	Stroke+X
	φ40-φ50	1/2.5	Stroke+X
	φ63 - φ100	1/3	Stroke+X
	φ125	1/3.5	Stroke+X

- When the calculated WF has decimals, raise them to the next whole number.

Maximum allowable pressure of TC type

The TC attachment is at the normal position (center), and load is applied on the one side only.

Bore	φ32	φ40	φ50	φ63	φ80	φ100	φ125
Maximum allowable pressure (MPa)	10	10	10	10	7	7	7

Dimensional table

Symbol Bore	A	B		KK	MM	OF	S	SL	VD
		Standard type	Cutting oil proof type						
φ32	18	φ30f9	φ34f9	M14 X1.5	φ18	φ17	14	10	10
φ40	22	φ34f9	φ40f9	M16 X1.5	φ22	φ21	17	9	12
φ50	28	φ42f9	φ46f9	M20 X1.5	φ28	φ26	22	11	15
φ63	36	φ50f9	φ55f9	M27 X2	φ36	φ34	30	14	15
φ80	45	φ60f9	φ65f9	M33 X2	φ45	φ43	38	17	8
φ100	56	φ72f9	—	M42 X2	φ56	φ54	50	21	16
φ125	63	φ88f9	—	M48 X2	φ70	φ68	60	24	13

Symbol Bore	AE	BB	BD	DE	E	EE	FF	FP	HL	JR	PJ	PK	PL
φ32	12 Note)	7	30	φ21.5	□ 45	Rc1/4	G1/4	35	103	R2	56	66	12
φ40	12	7	30	φ25.5	□ 52	Rc3/8	G3/8	33	105	R2	58	68	14
φ50	12	9	38	φ25.5	□ 65	Rc3/8	G3/8	33	105	R2	58	68	14
φ63	14	9	43	φ30 or more	□ 76	Rc1/2	G1/2	35	117	R2.5	66	76	16
φ80	14	11	53	φ30 or more	□ 94	Rc1/2	G1/2	42	131	R2.5	74	84	15
φ100	16	14	63	φ36.9 or more	□ 114	Rc3/4	G3/4	38	143	R3	86	96	19
φ125	16	16	73	φ36.9 or more	□ 140	Rc3/4	G3/4	39	151	R3	93	103	19

Symbol Bore	PV	PW	TD	TL	TM	UM	UW	WF	XV	XW	ZJ	ZK
φ32	63	68	φ16f8	12	55h14	79	55	25	88	93	128	161
φ40	62	67	φ16f8	12	63h14	87	63	25	87	92	130	159
φ50	62	67	φ20f8	16	76h14	108	75	32	94	99	137	166
φ63	68	73	φ25f8	20	88h14	128	88	34	102	107	151	180
φ80	79	84	φ32f8	25	114h14	164	107	35	114	119	166	203
φ100	81	86	φ40f8	32	132h14	196	126	41	122	127	184	213
φ125	85.5	90.5	φ50f8	40	165h14	245	157	41	126.5	131.5	192	222

Notes) ● For the cylinder with 32 mm bore and the G thread port, the thread length adjuster spacer is installed on the rod side.

● Allowance of MM is f8.

With boots

Bore Symbol	φ32	φ40	φ50	φ63	φ80	φ100	φ125
WW	φ40	φ50	φ50	φ71	φ80	φ100	φ100
X	56	56	58	71	73	75	89

Switch set

100H-2R	2	SD	Bore	B	B	Stroke	-	A	B	Switch symbol	Switch quantity
---------	---	----	------	---	---	--------	---	---	---	---------------	-----------------

AX type · AZ type (Contact, no contact)

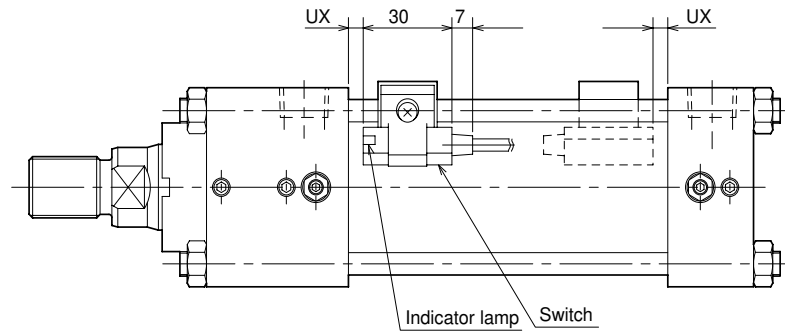
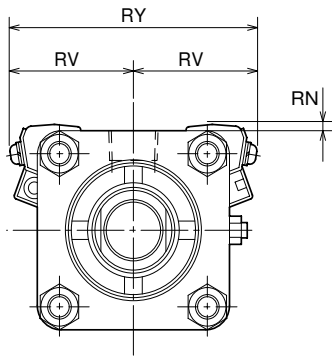

WR type (Contact) · WS type (No contact/Two-wire two-lamp type) (Cutting oil proof type)

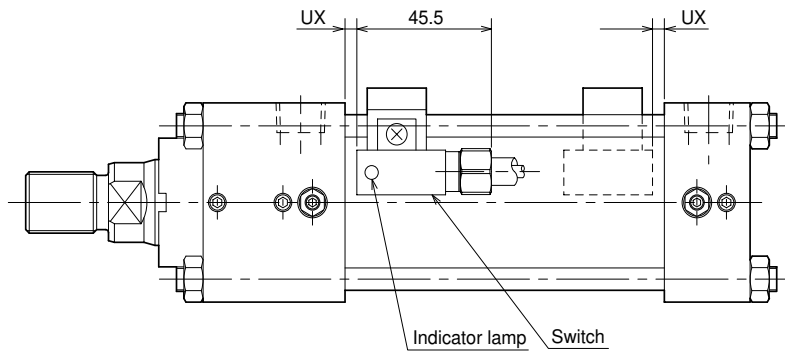
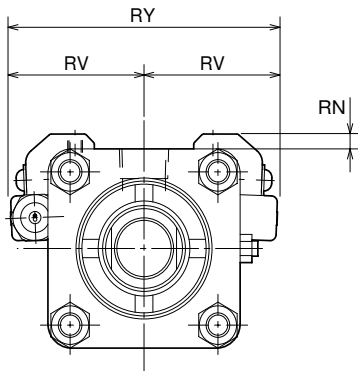

Dimensional table

Symbol Bore	RN		RV		RY		UX (single rod)			UX (double rod)		
	AX type	WR·WS type	AX type	WR·WS type	AX type	WR·WS type	AX type	WR type	WS type	AX type	WR type	WR·WS type
φ32	4	6	33	39	66	78	4	2	4	9	7	9
φ40	4	5	37	40	74	80	5	2	4	10	7	9
φ50	3	5	42	46	84	92	5	2	4	10	7	9
φ63	1	4	46	51	92	102	6	3	5	11	8	10
φ80	2	3	55	58	110	116	8	5	7	13	10	12
φ100	3	5	65	70	130	140	11	8	10	16	13	15
φ125	4	1	76	80	152	160	14	11	13	19	16	18

Note) ● Figures on the previous page show the AX type switch (rear wiring). As for the AZ type switch (upper wiring), take into consideration the bending radius of cord.

- The dimension UX indicates the optimum switch mounting position at the detection of the stroke end.

Working range and difference

Bore mm	Contact				No contact			
	AX1**		WR type		AX2**		WS type	
	Working range	Difference	Working range	Difference	Working range	Difference	Working range	Difference
φ32	4 - 14	2 or smaller	5 - 10	2 or smaller	3 - 8	1 or smaller	6 - 16	1 or smaller
φ40	5 - 10		6 - 9		3 - 6		12 - 14	
φ50			8 - 10		3 - 7		10 - 12	
φ63	7 - 11		9 - 11				4 - 10	
φ80	5 - 12		10 - 17					
φ100			8 - 17					
φ125								

Rod end attachment

● Rod end eye (T-end)

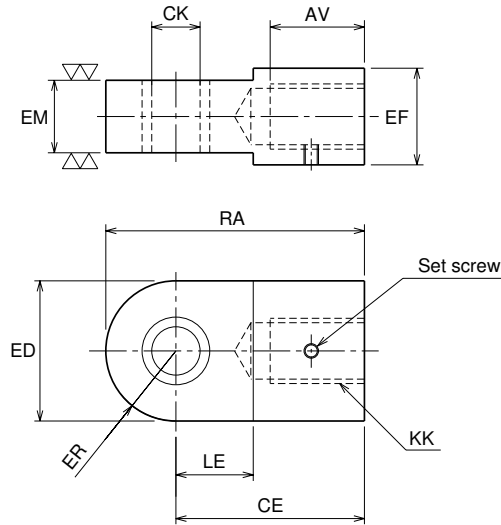

● Rod end clevis (Y-end)

Bore from 32 mm to 80 mm

Bore from 100 mm to 125 mm

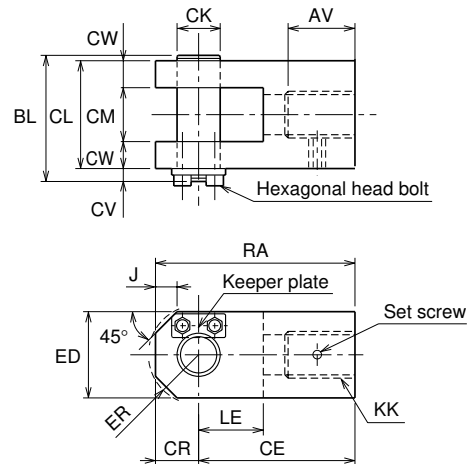
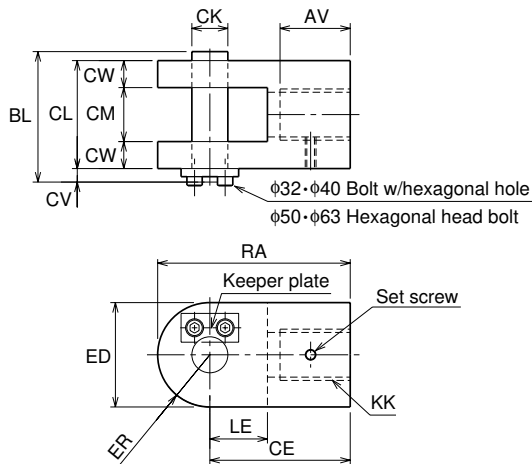

● Delivery of rod end attachment (T-end, Y-end)

(1) In the case that the lock nut and rod end attachment are additionally ordered

The rod end attachment and lock nut are temporarily assembled to the piston rod for delivery. Since the lock nut is not tightened, tighten it after the position of the rod end attachment is adjusted. No set screw is included.

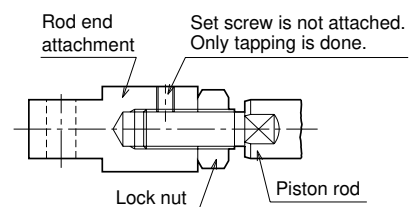

(2) In the case that only the rod end attachment is additionally ordered (without lock nut)

The rod end attachment is tightened to the piston rod, and a drill hole is made on the piston rod for delivery.

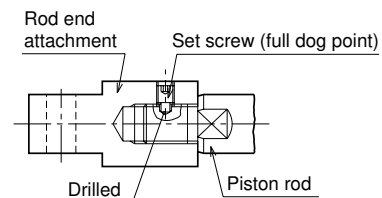

If a drill hole is unnecessary, advise us.

Dimensional table/rod end eye (T-end)

Symbol Bore	Part code	AV	CE	EF	KK	RA	Set screw
φ 32	RTH-14-H	21	50	25	M14 × 1.5	67	M6
φ 40	RTH-16-3-H	25	55	30	M16 × 1.5	72	M6
φ 50	RTH-20-4-H	31	67	35	M20 × 1.5	84	M6
φ 63	RTH-27-H	39	78	40	M27 × 2	107	M6
φ 80	RTH-33-1-H	48	94	50	M33 × 2	123	M6
φ 100	RTH-42-1-H	59	112	65	M42 × 2	146	M8
φ 125	RTH-48-4-H	66	135	75	M48 × 2	185	M10

Symbol Bore	CK	ED	EM	ER	LE
φ 32	φ12H9	34	16 ⁰ _{-0.27}	R17	19
φ 40	φ14H9	34	20 ⁰ _{-0.33}	R17	19
φ 50	φ14H9	34	20 ⁰ _{-0.33}	R17	19
φ 63	φ20H9	58	30 ⁰ _{-0.33}	R29	32
φ 80	φ20H9	58	30 ⁰ _{-0.33}	R29	32
φ 100	φ28H9	68	40 ⁰ _{-0.39}	R34	39
φ 125	φ36H9	100	50 ⁰ _{-0.39}	R50	54

Dimensional table/rod end clevis (Y-end)

Symbol Bore	Part code	AV	CE	KK	RA	Set screw
φ 32	RYH-14-H	21	50	M14 × 1.5	67	M6
φ 40	RYH-16-3-H	25	55	M16 × 1.5	72	M6
φ 50	RYH-20-4-H	31	67	M20 × 1.5	84	M6
φ 63	RYH-27-H	39	78	M27 × 2	107	M6
φ 80	RYH-33-1-H	48	94	M33 × 2	123	M6
φ 100	RYH-42-1-H	59	112	M42 × 2	143	M8
φ 125	RYH-48-4-H	66	135	M48 × 2	178	M10

Symbol Bore	BL	CK	CL	CM	CR	CV	CW	ED	ER	J	LE
φ 32	42	φ12H9/f8	32	16 ^{+0.69} _{+0.29}	—	8	8	34	R17	—	19
φ 40	50	φ14H9/f8	40	20 ^{+0.70} _{+0.30}	—	8	10	34	R17	—	19
φ 50	50	φ14H9/f8	40	20 ^{+0.70} _{+0.30}	—	8	10	34	R17	—	19
φ 63	72	φ20H9/f8	60	30 ^{+0.70} _{+0.30}	—	10	15	58	R29	—	32
φ 80	72	φ20H9/f8	60	30 ^{+0.70} _{+0.30}	—	10	15	58	R29	—	32
φ 100	92	φ28H9/f8	80	40 ^{+0.91} _{+0.31}	31	10	20	65	R33	22	39
φ 125	115	φ36H9/f8	100	50 ^{+0.92} _{+0.32}	43	13	25	90	R48	24	54

● Parallel pin

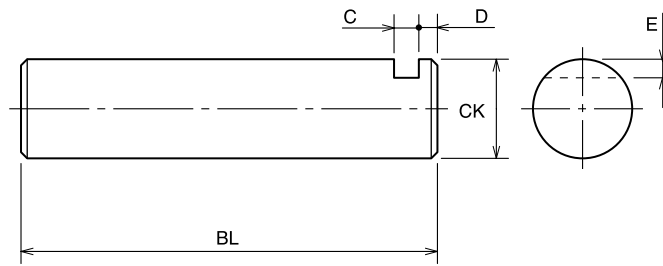

● Keeper plate

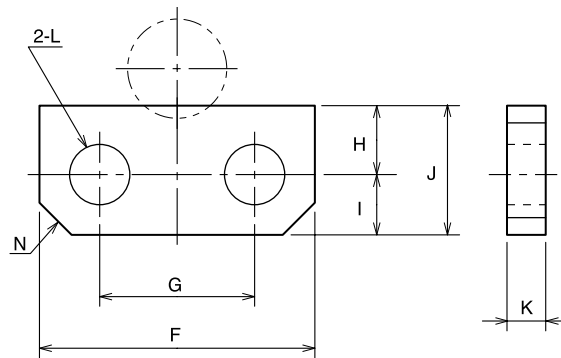

Dimensional table/Parallel pin

Symbol Bore	Rod B				
	BL	C	CK	D	E
φ 32	42	4	φ12f8	4	2
φ 40	50	4	φ14f8	4	2
φ 50	50	4	φ14f8	4	2
φ 63	72	5.5	φ20f8	4.5	3
φ 80	72	5.5	φ20f8	4.5	3
φ 100	92	5.5	φ28f8	4.5	4
φ 125	115	7	φ36f8	6	5

Dimensional table/Keeper plate

Symbol Bore	Rod B								Mounting bolt
	F	G	H	I	J	K	L	N	
φ 32	19	10	5.5	4.5	10	3	φ 5.5	C2.5	M5
φ 40	19	10	5.5	4.5	10	3	φ 5.5	C2.5	M5
φ 50	19	10	5.5	4.5	10	3	φ 5.5	C2.5	M5
φ 63	32	17	8	8	16	4.5	φ 6.6	C4	M6
φ 80	32	17	8	8	16	4.5	φ 6.6	C4	M6
φ 100	38	23	7	8	15	4.5	φ 6.6	C4	M6
φ 125	44	24	11	11	22	6	φ 9	C3	M8

● Lock nut

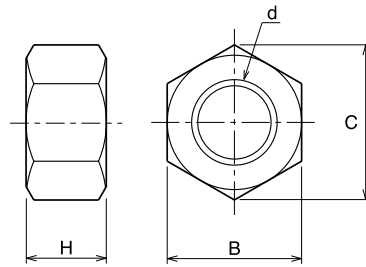

● Thread length with lock nut

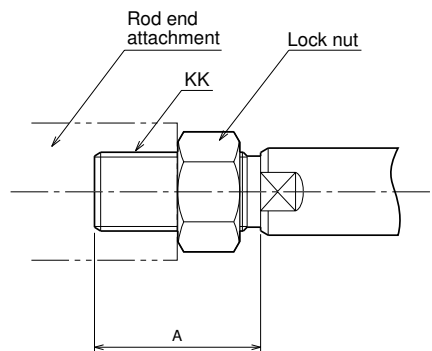

The standard fitting length of the rod end attachment and piston rod is approximately 80% of the thread diameter. When using a lock nut, it is required to lengthen the thread length (A) as shown in the figure above. If you order a cylinder with lock nut attached (symbol: K), the thread length (A) is as shown in the table on the next page.

Dimensional table/Lock nut

Bore	Symbol	Rod B			
	Parts model	B	C	d	H
φ 32	LNH-14F-H	22	25.4	M14 × 1.5	11
φ 40	LNH-16F-1-H	24	27.7	M16 × 1.5	13
φ 50	LNH-20F-2-H	30	34.6	M20 × 1.5	16
φ 63	LNH-27F-H	41	47.3	M27 × 2	22
φ 80	LNH-33F-H	50	57.7	M33 × 2	26
φ 100	LNA-42F-1-H	65	75.0	M42 × 2	34
φ 125	LNA-48F-2-H	75	86.5	M48 × 2	38

Dimensional table/A when lock nut is used (long thread)

Bore	Symbol	Rod B	
	A	KK	
φ 32	28	M14 × 1.5	
φ 40	32	M16 × 1.5	
φ 50	40	M20 × 1.5	
φ 63	54	M27 × 2	
φ 80	66	M33 × 2	
φ 100	84	M42 × 2	
φ 125	96	M48 × 2	

Special specification at the rod end For rod size B

(Please consult us in case of 'A rod' or the case that doesn't go for 'A01' or 'A00' below.)

- You can easily order following categorized items using the Semi-standard symbols and dimensional parameters.
(No need to specify dimensional parameters if you would apply the basic dimensions.)

How to order Series Model number – X Semi-standard symbols Dimensional parameters

Semi-standard symbols: **A01** Parameter KM and KP need to be specified as a pair.

Optional parameters: **A KM KP W WF**

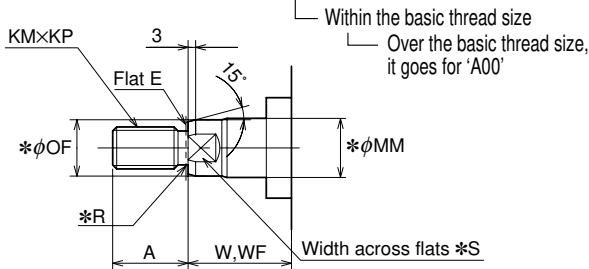
**The basic dimension table (=100H-2 Standard dimension)**

Bore	A	KM	KP	*MM	*OF	*R	*S	W (FA type)	WF (Others)
φ32	18	14	1.5	φ18	φ17	1	14	35	25
φ40	22	16	1.5	φ22	φ21	1.6	17	35	25
φ50	28	20	1.5	φ28	φ26	1.6	22	41	32
φ63	36	27	2	φ36	φ34	2	30	48	34
φ80	45	33	2	φ45	φ43	2	38	51	35
φ100	56	42	2	φ56	φ54	2	50	57	41
φ125	63	48	2	φ70	φ68	2	60	57	41

Semi-standard symbols: **A00** Parameter KM and KP need to be specified as a pair.

Optional parameters: **A KM KP W WF**

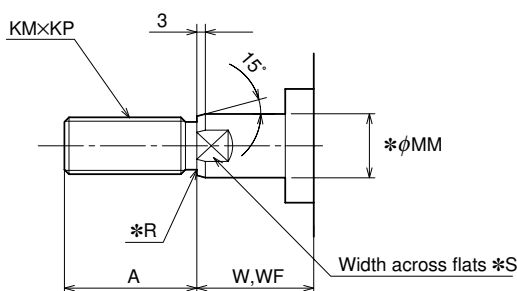
**The basic dimension table (Standard dimension)**

Bore	A	KM	KP	*MM	*R	*S	W (FA type)	WF (Others)
φ32	25	16	1.5	φ18	1	14	35	25
φ40	30	20	1.5	φ22	1	19	35	25
φ50	35	24	1.5	φ28	1	24	41	32
φ63	45	30	1.5	φ36	1.6	30	48	34
φ80	60	39	1.5	φ45	1.6	41	51	35
φ100	75	48	1.5	φ56	1.6	50	57	41
φ125	95	64	2	φ70	2	65	57	41

Occasion ■ Slight dimension change on the basis of 100H-2 series standard thread size.

Note ■ A01's basic dimension shows the original 100H-2's standard itself. Don't use semi-standard symbols to avoid confusion in such a case.

■ In case of over sized thread, the symbol should be 'A00', not 'A01'.

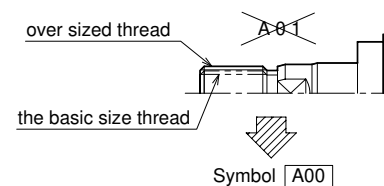

ex. • bore:40mm, rod:B, thread size:M16×2, WF:80mm
(order) 100H-2 1CA40BB250-AB-X A01
KM-16, KP-2, WF-80
(manufacturing) rod end style A=22, KM=16, KP=2,
WF=80, φMM=φ22, φOF=φ21, R=1.6, S=17

• bore:100mm, rod:B, thread size:M45×1.5
'A01' can't be used. Refer to the symbol 'A00'.

Occasion ■ In case of ordering over sized thread
■ In case of applying the standard thread size of 70/140H-8 series

Note ■ On this symbol 'A00' the basic dimension is completely different from that of 'A01'. A00's basic is originally based on the standard of 70/140H-8.

ex. • bore:63mm, rod:B, 'A00' basic dimensions
(order) 100H-2R 2FA63BB300-BC-X A00
(manufacturing) rod end style A=45, KM=30,
KP=1.5, W=48, φMM=φ36, R=1.6, S=30

• bore:100mm, rod=B, thread size M45×1.5,
other dimensions from 'A01' basic
(order) 100H-2 2CB100BR500-AB-X A00
KM-45, KP-1.5, A-56
(manufacturing) rod end style A=56, KM=45,
KP=1.5, WF=41, φMM=φ56, R=1.6, S=50

• bore:50mm, rod:B, thread size:M22×1.5,
WF:100mm, other dimensions from the basic
(order) 100H-2 2CA50BB500-AB-X A00
KM-22, KP-1.5, WF-100
(manufacturing) rod end style A=35, KM=22,
KP=1.5, WF=100, φMM=φ28, R=1, S=24

- Dimensions indicated by *Mark are fixed as our semi-standard.
- You are requested to consult us if you would like to change fixed dimensions.

Setting method of switch detecting position

AX Type · AZ Type

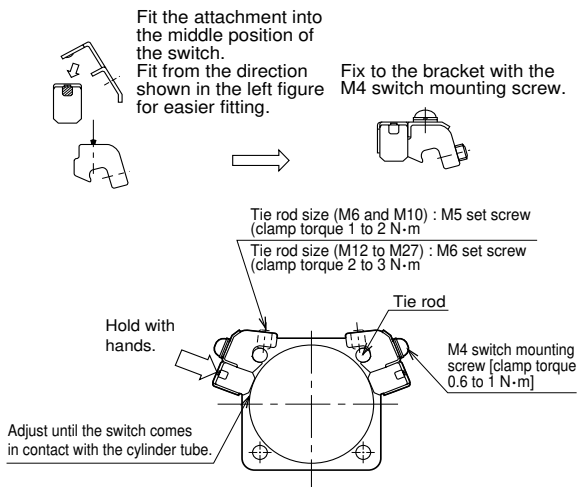

WR Type · WS Type

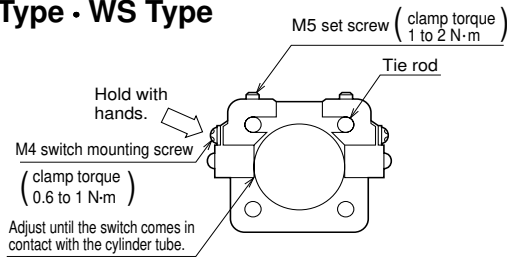

Notes on assembly

Fastening of tie rod

- Apply lubrication oil (fluid is applicable) to the nut bearing surface and the thread surface before fastening the tie rods. Fastening with dry surfaces may cause failure in appropriate tie rod axial tension.
- When fastening the tie rods, DO NOT fasten only one tie rod at once, but fasten them gradually in the order shown in the right diagram. Uneven fastening of them may cause malfunctions or cracks of cylinders.

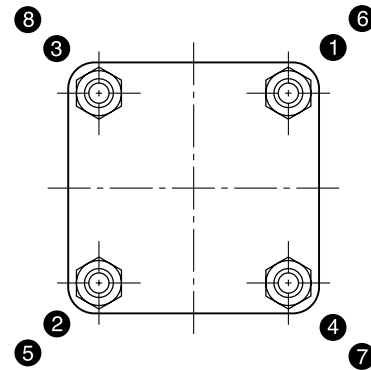

Specified tie rod tightening torque table (Note:Molybdenous Grease should be used.)

Bore (mm)	φ32	φ40	φ50	φ63	φ80	φ100	φ125
Tie rod thread	M6 × 1	M6 × 1	M8 × 1	M8 × 1	M10 × 1.25	M14 × 1.5	M16 × 1.5
Tightening torque N·m	8	8	22	22	41	120	170

1. Loosen the two set screws with an Allen wrench, and move them along with the tie rod.
2. Adjust the detecting position (for the 2-lamp type, the position that the green lamp lights up) 2 to 5 mm (about half of the working range is appropriate) before the required position that the switch indicator lamp starts to light up (ON). Then, gently hold the top of the switch so that the cylinder tube contacts the detecting face of the switch, and clamp the set screw with the appropriate clamp torque.
Note) Inappropriate clamp torque may cause the off-center of the switch position.
3. The indicator lamp lights up when the switch is set to the ON position.
4. Switches can be mounted to any of four tie rods and on the most suitable position depending on the mounting space of the cylinder and wiring method.
5. Mount a switch to the most suitable position to detect the stroke end with the “Switch mounting dimension” (dimension UX).